

TC1 SERIES

Manual Tool Changers | Ordering Information

Base Model: **TC1** — Model Size: **050** — Robot or Tool Plate: **M-01**

Robot Plate

M-00 Application Specific - User adds mounting hole pattern

M-01 ISO-9409-1-50-4-M6 mounting pattern with boss

(See robot compatibility table on next page)

Tool Plate

T-00 Application Specific - User adds mounting hole pattern

T-01 DirectConnect mounting to DESTACO Robohand products

T-02 ISO-9409-1-50-4-M6 mounting pattern



Shown mounted to cobot with robot plate and tool plate coupled.



Compatible with multiple brands of cobots.

TC1-050M-01
Robot Plate
ISO 9409 Mounting
(see page 3).

Patent Pending

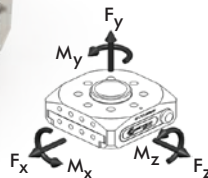

Specifications:		TC1
Max. Payload:	Kg [lb]	10 [22]
Coupled Weight:	Kg [lb]	~0.35 [0.77]
Robot Plate Weight:	Kg [lb]	~0.21 [0.47]
Tool Plate Weight:	Kg [lb]	~0.14 [0.30]
Repeatability:	mm [in]	±0.025 [0.001]
Temperature Range:	C° [F°]	-30° to 66° [-22° to 151°]
Max Moment (My, Mz, Mx)	Nm [in-lb]	100 [885]
Max Force (Fy, Fz)	N [lbf]	1000 [225]
Max Force (Fx)	N [lbf]	100 [22.5]



TC1-050T-01
Tool Plate with DirectConnect
Robohand Mounting.

Optional Accessories

Description	Order no.
8-Pin M8 Socket Connector Electrical Pass-thru for Robot Plate	TC1-E01M-C01
8-Pin M8 Plug Connector Electrical Pass-thru for Robot Plate	TC1-E02M-C01
8-Pin M8 Plug Connector Electrical Pass-thru for Tool Plate	TC1-E01T-C01
8-Pin M8 Socket Connector Electrical Pass-thru for Tool Plate	TC1-E02T-C01
PNP Magneto-resistive 4mm Sensing Module for Tool Plate	TC1-E01T-P01
NPN Magneto-resistive 4mm Sensing Module for Tool Plate	TC1-E02T-N01
Tool Plate Holder	TC1-050H-01
Seal Replacement Kit	SLKT-480

TC1 SERIES

Manual Tool Changers | Compatibility Charts

TC1-050M-01 Robot Plate - Robot Compatibility

Robot Manufacturer	Model
GENERIC	Any model with ISO-9409-1-50-4-M6 Pattern
STAUBLI	TX2touch-90, 90L, 90XL
UNIVERSAL ROBOTS	UR3, UR5, UR10, UR16
TECHMAN/OMRON	TM5-700, TM5-900, TM12, TM14
KUKA	LBR iiwa 7 R800, LBR iiwa 14 R820
AUBO	I3, I5, I7, I10
ESI	C-7, C-15
F&P PERSONAL ROBOTICS	P-ROB 2R-24V, 48V
HANWHA PRECISION MACHINERY	HCR-3, 5, 12
JAKA/KUNLIN	ZU 7, 12
MODBOT	COBOT, SCARA
ROZUM	PULSE 75, 90
SIASUN	GCR5, GCR14, GCR20, SCR3, SCR5
HAN'S ROBOTS	ELFIN 3, 5, 10
FRANKA EMIKA	PANDA

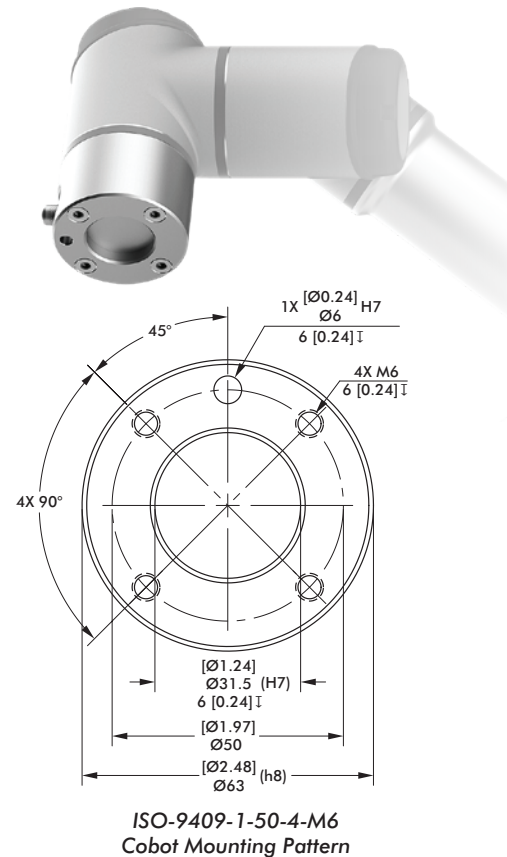

TC1-050T-01 Tool Plate - Robohand Compatibility

Robohand Products	Compatible Series	Description
DPE	200-25	Electric 2 Jaw Parallel Gripper
DGC	All Sizes	
DPDL	047, 056, 088, 125	
DPDS		
DPG		
DPL	2520, 2535	
DPP	All Sizes	
DPW	250M, 375M, 500M	
G110, G120	All Sizes	
DCT	12M, 16M, 20M, 25M	Pneumatic 2 Jaw Angular Gripper
DRF	All Sizes	Rotary Actuator
DRG		
DLM		Miniature Linear Rail Thruster Slide
DLT	06, 08, 10, 12, 16	Linear Thruster Slide
DLB		Linear Base Slide



Shown with G120 Parallel Gripper and TC1-E01T-P01 Magneto-resistive Sensors.

TC1 ROBOT PLATE

Manual Tool Changers | Dimensions

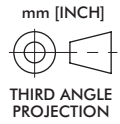

TC1-050M-00 Blank Robot Plate (general unit dimensions shown apply to all models)



Requires mounting pattern added by user for their specific application.

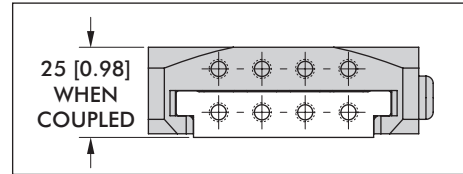

Weight: 0.213 [0.47]

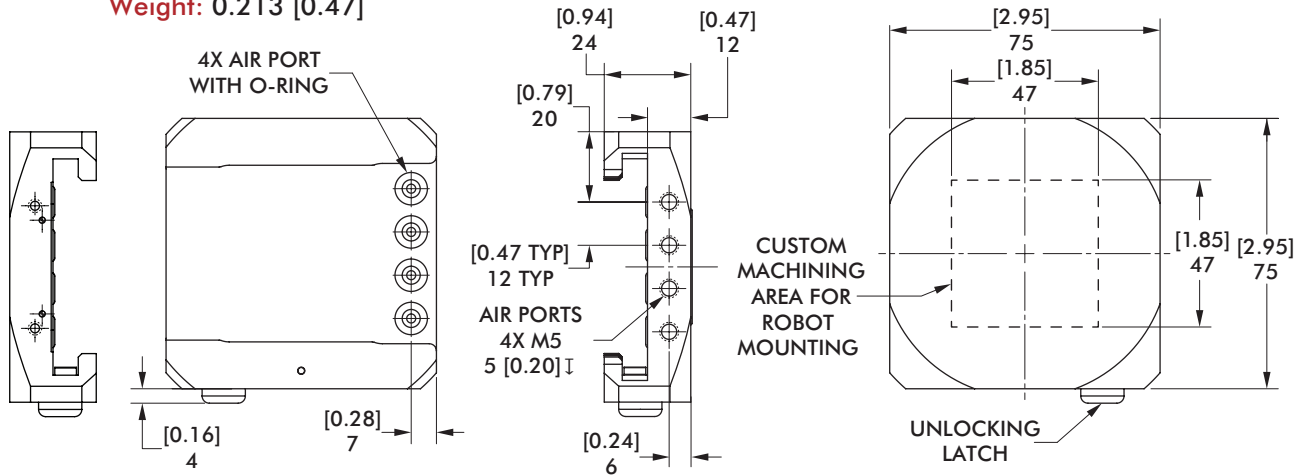

TC1-050M-01 ISO 9409 Robot Plate (see TC1-050M-00 for general dimensions)

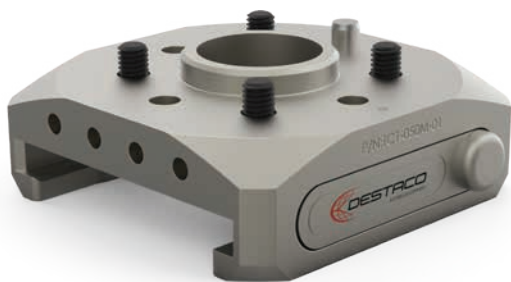

Compatible with multiple brands of cobots. Verify cobot arm mounting pattern.

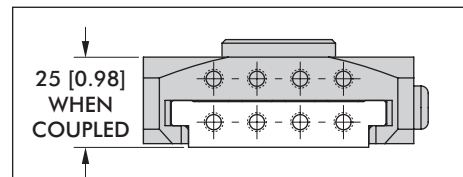

Fasteners, dowel pins, and tools included.

Weight: 0.212 [0.47]

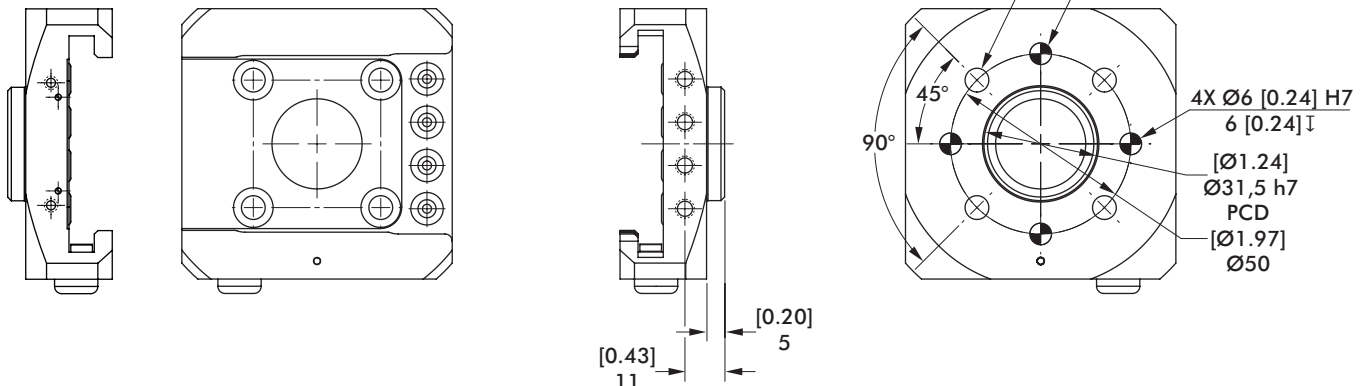

TC1-050T-00 Blank Tool Plate (general unit dimensions shown apply to all models)

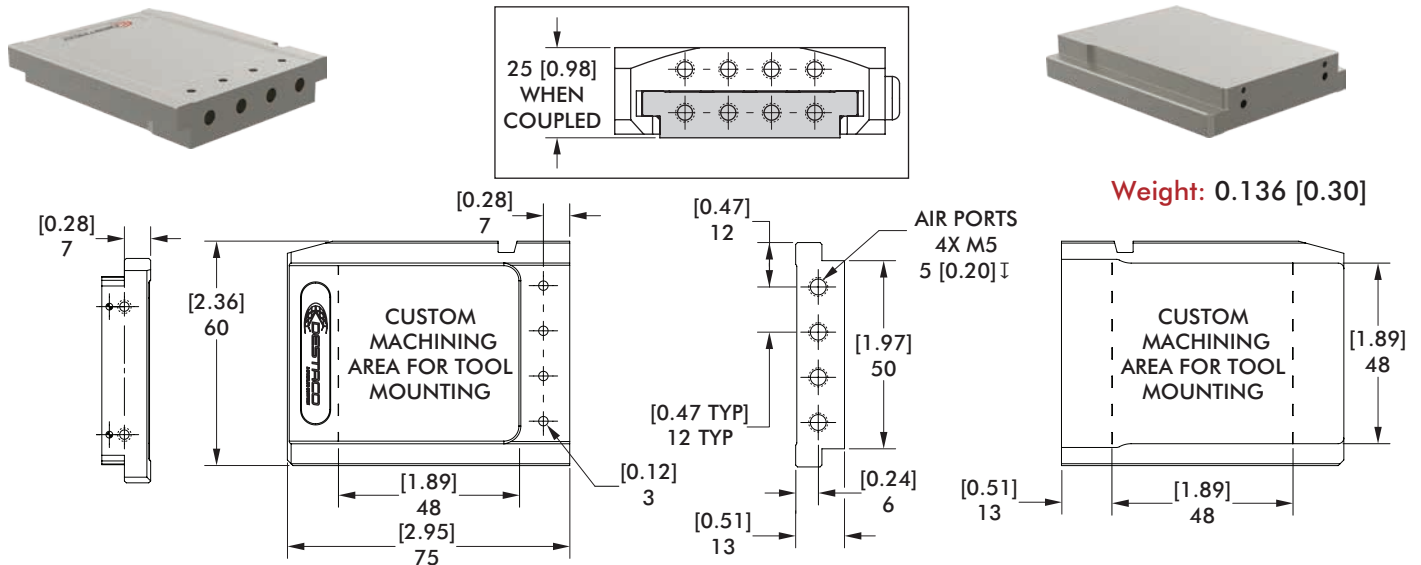

TC1-050T-01 DirectConnect Robohand Mounting Tool Plate (see TC1-050T-00 for general dimensions)

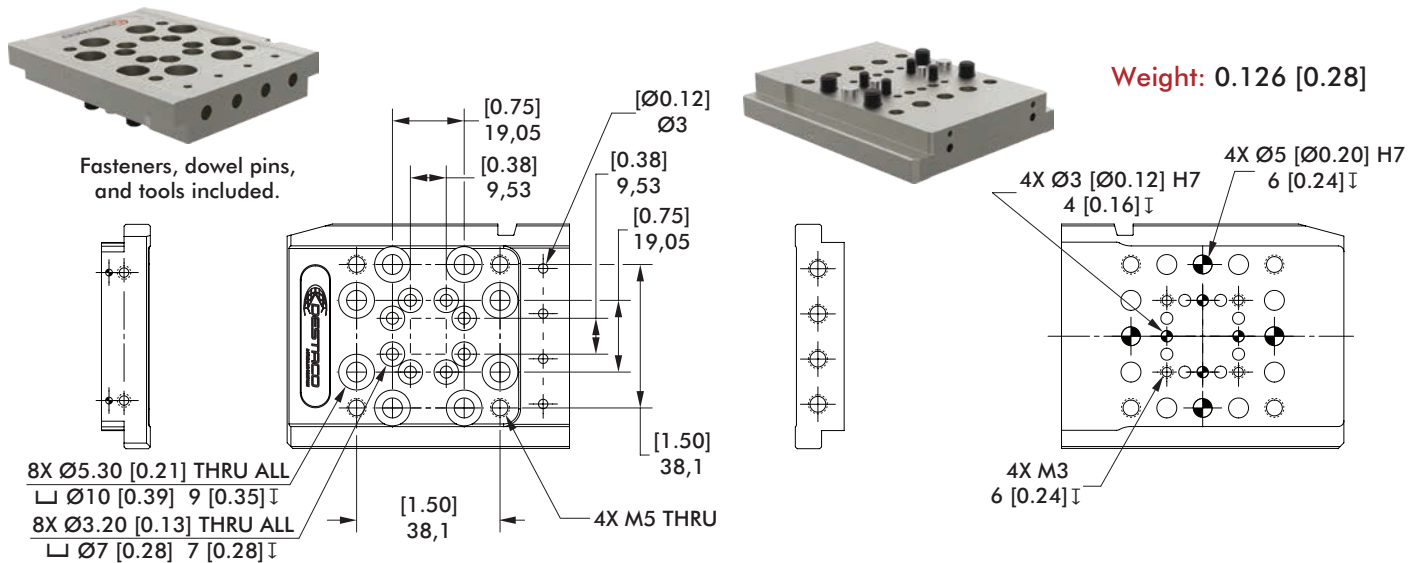

TC1-050T-02 ISO 9409 Mounting Pattern Tool Plate (see TC1-050T-00 for general dimensions)

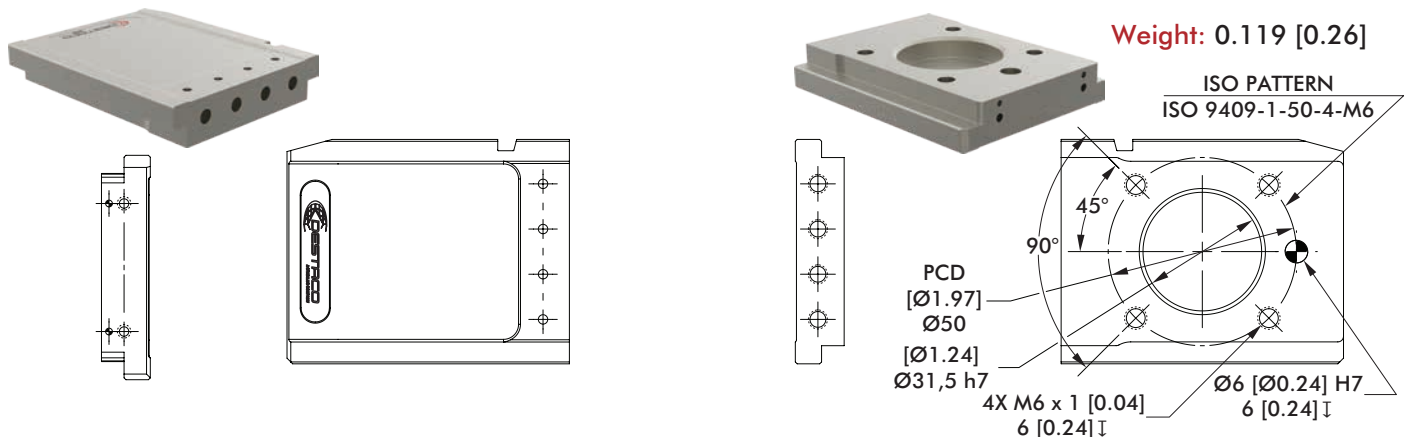

TC1 ELECTRICAL MODULES

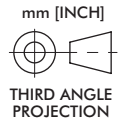

Manual Tool Changers | Dimensions and Specifications

TC1-E01M-C01 8-Pin M8 Socket Electrical Pass-thru Module for Robot Plate (Universal Robot Compatible)

TC1-E02M-C01 8-Pin M8 Plug Electrical Pass-thru Module for Robot Plate (TechMan Cobot Compatible)

CABLE LENGTH
TC1-E01M-C01 145 [5.71]
TC1-E02M-C01 175 [6.80]

PLUG CONNECTOR TC1-E02M-C01
 SOCKET CONNECTOR TC1-E01M-C01
 INTERFACE PINS

PLUG CONNECTOR TC1-E02M-C01	SOCKET CONNECTOR TC1-E01M-C01	INTERFACE PIN
1	1	1
2	2	2
3	3	3
4	4	4
5	5	8
6	6	5
7	7	6
8	8	7

TC1-E01M-C01 with 8-Pin M8 Socket shown.
Fasteners and tools included.

ELECTRIC SPECIFICATION					
SYMBOL	CHARACTERISTIC	MIN	TYP	MAX	UNIT
V _{dd}	CONDUCTOR VOLTAGE	-	-	30	V
I _{dd}	CONDUCTOR CURRENT	-	-	1.5	A

TC1-E01T-C01 8-Pin M8 Plug Electrical Pass-thru Module for Tool Plate (Universal Robot Compatible)

TC1-E02T-C01 8-Pin M8 Socket Electrical Pass-thru Module for Tool Plate (TechMan Cobot Compatible)

2X Ø3 [0.12] THRU ALL
 √Ø6 [0.24] x 90°

PLUG CONNECTOR TC1-E01T-C01
 SOCKET CONNECTOR TC1-E02T-C01
 INTERFACE PINS

PLUG CONNECTOR TC1-E01T-C01	SOCKET CONNECTOR TC1-E02T-C01	INTERFACE PIN
1	1	1
2	2	2
3	3	3
4	4	4
5	5	8
6	6	5
7	7	6
8	8	7

TC1-E01T-C01 with 8-Pin M8 Plug shown.
Fasteners and tools included.

ELECTRIC SPECIFICATION					
SYMBOL	CHARACTERISTIC	MIN	TYP	MAX	UNIT
V _{dd}	CONDUCTOR VOLTAGE	-	-	30	V
I _{dd}	CONDUCTOR CURRENT	-	-	1.5	A

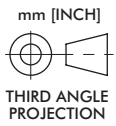

TC1 ELECTRICAL MODULES

Manual Tool Changers | Dimensions and Specifications

TC1-E01T-P01 PNP Magneto Resistive 4mm Sensing Module for Tool Plate
(For use with grippers to detect jaw positioning. Universal Robot Compatible.)

TC1-E02T-N01 NPN Magneto Resistive 4mm Sensing Module for Tool Plate
(For use with grippers to detect jaw positioning. TechMan Cobot Compatible.)

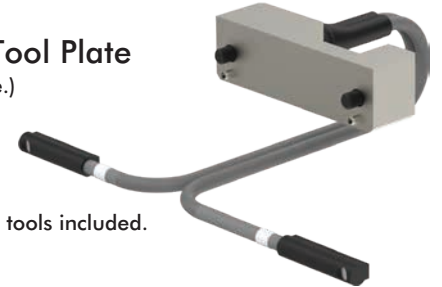

Fasteners and tools included.

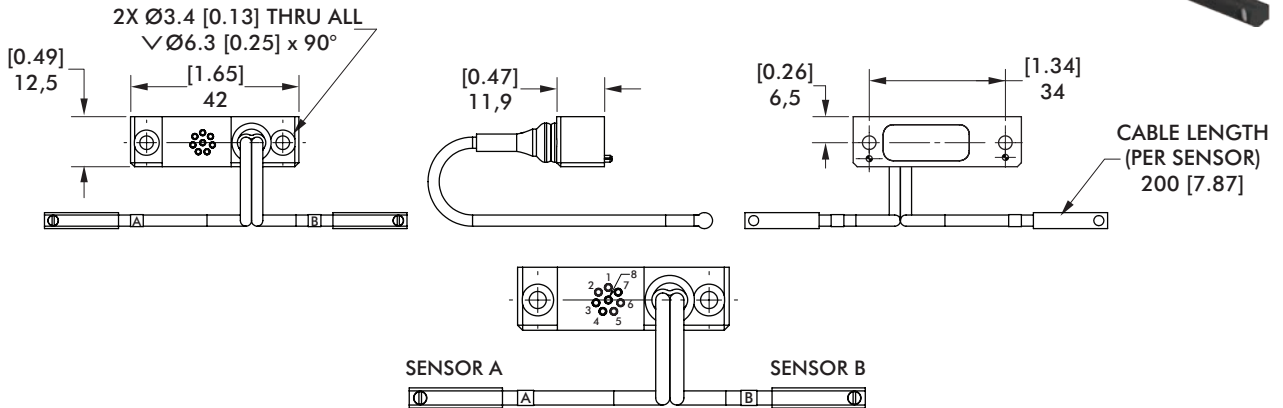

INTERFACE PIN		SIGNAL DESCRIPTION
TC1-E01T-P01	TC1-E02T-N01	
3	3	SIGNAL A
4	2	SIGNAL B
8	1	POWER (4.5~28VDC)
7	7	GND (OV)

ELECTRIC SPECIFICATION					
SYMBOL	CHARACTERISTIC	MIN	TYP	MAX	UNIT
V _{dd}	SUPPLY VOLTAGE	4.5	-	28	V DC
I _{dd}	OUTPUT CURRENT (PER SENSOR)	-	-	100	mA
I _q	QUIESCENT (IDLE) CURRENT	-	20	-	mA



Tool Changer shown with TC1-E01M-C01 and TC1-E01T-P01 modules installed.



Tool Changer shown with TC1-E01M-C01 and TC1-E02T-N01 modules installed.

TC1 TOOL HOLDER

Manual Tool Changers | Dimensions

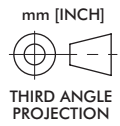

TC1-050H-01 Tool Holder

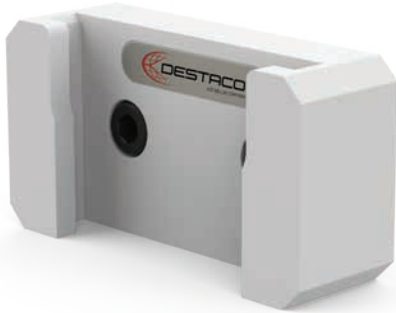

Fasteners and tools included.

Material: Acetal Plastic

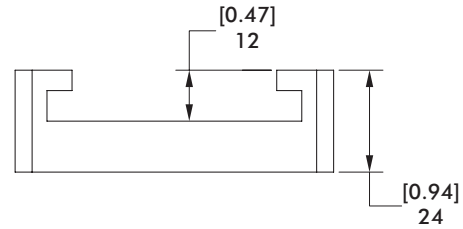
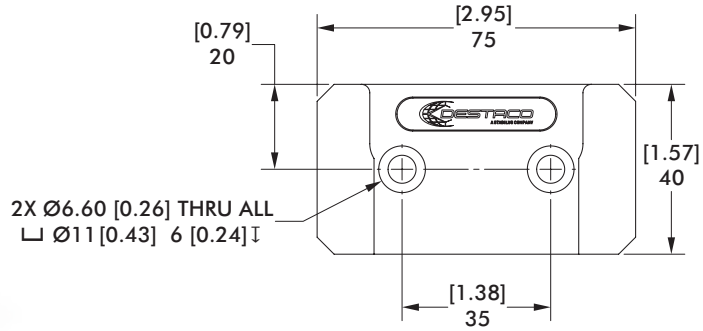

Tool Plate shown with a Robohand DPE-200 Electric Parallel Gripper placed in Tool Holder.

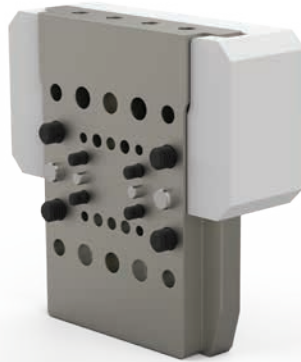

Tool Plate shown placed in Tool Holder.

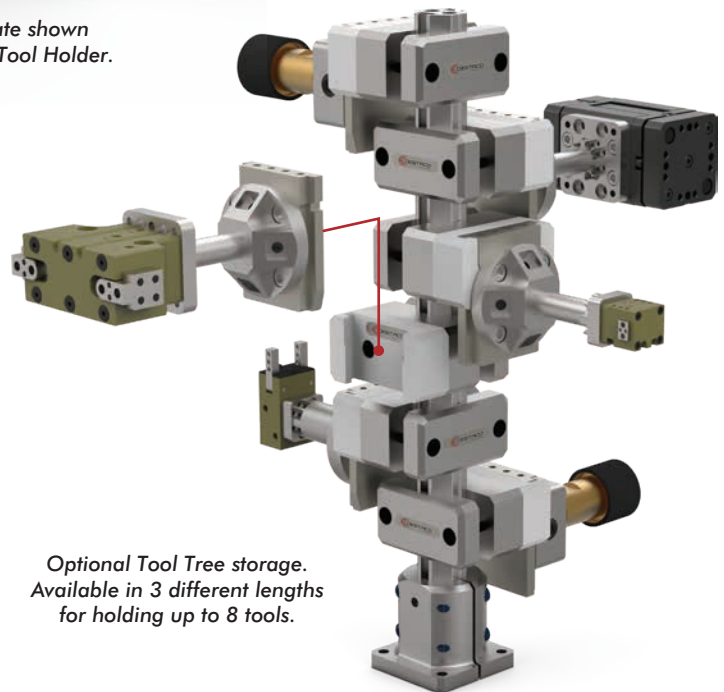

Optional Tool Tree storage. Available in 3 different lengths for holding up to 8 tools.

