

GREAT GATSBY 450X1200D

LED MIRROR

PRODUCT CODE

GG45120D

SPECIFICATIONS

WIDTH	450mm
HEIGHT	1200mm
DEPTH	31mm
WEIGHT	10kg
ORIENTATION	Portrait/Landscape

FEATURES

Copper Free Mirror
LED Lighting (Adjustable Colour Temperature)
Backlit
Touch Sensor
Demister with 1 Hour Auto Cut-off

LIGHTING SPECIFICATIONS

CCT	2700K - 6500K
CRI	>80

INSTALLATION

Wall mount
Hardwire
Input voltage: 220-240v 50Hz

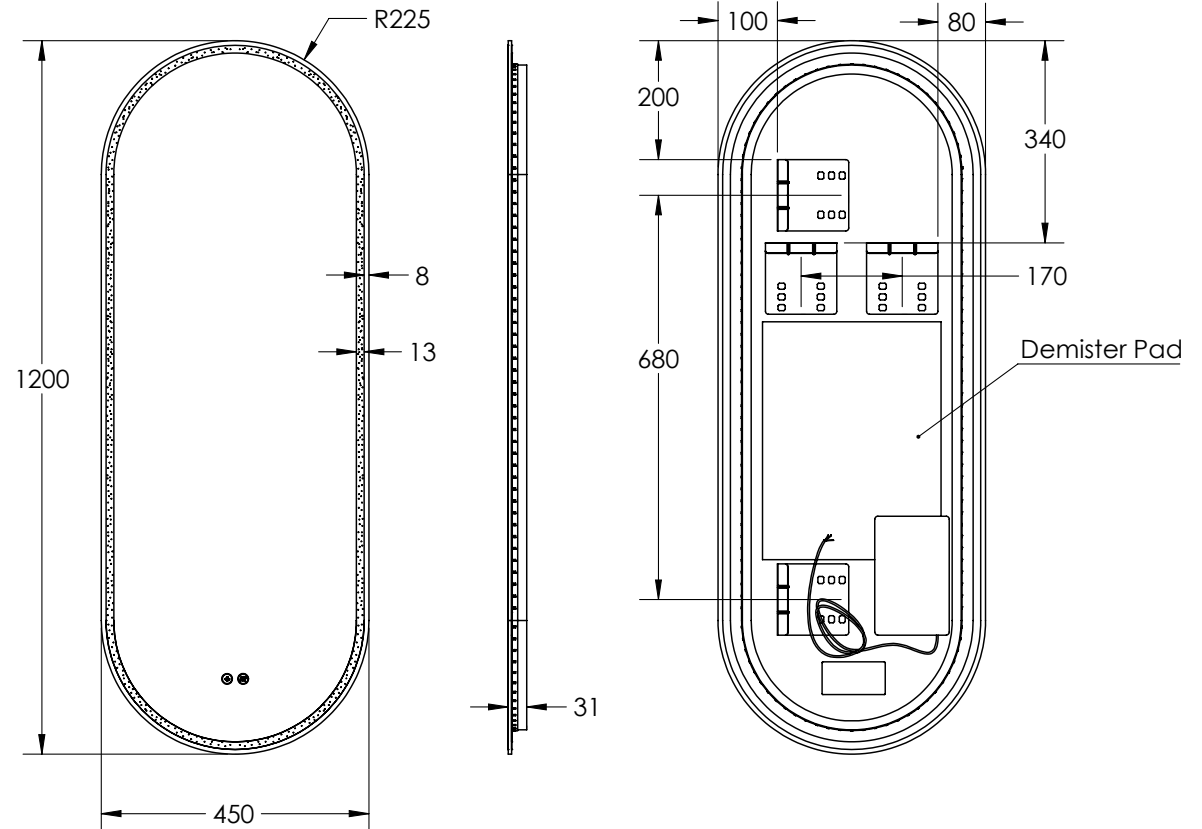

Disclaimer: All LED Products requiring hardwiring must be installed by a licensed electrician in accordance with local regulations. Sizes are in mm and nominal and should be checked prior to installation. Actual colours may vary so please check colour samples before ordering. Installation is acceptance of our products. Installation of faulty, warped, chipped or damaged products will void our warranty.

GREAT GATSBY 450X1200D

PRODUCT CODE

GG45120D

LED MIRROR

SPECIFICATIONS

WIDTH	450mm
HEIGHT	1200mm
DEPTH	31mm
WEIGHT	10kg
ORIENTATION	Portrait/Landscape

FEATURES

Copper Free Mirror
LED Lighting (Adjustable Colour Temperature)
Backlit
Touch Sensor
Demister with 1 Hour Auto Cut-off

LIGHTING SPECIFICATIONS

CCT	2700K - 6500K
CRI	>80

INSTALLATION

Wall mount
Hardwire
Input voltage: 220-240v 50Hz

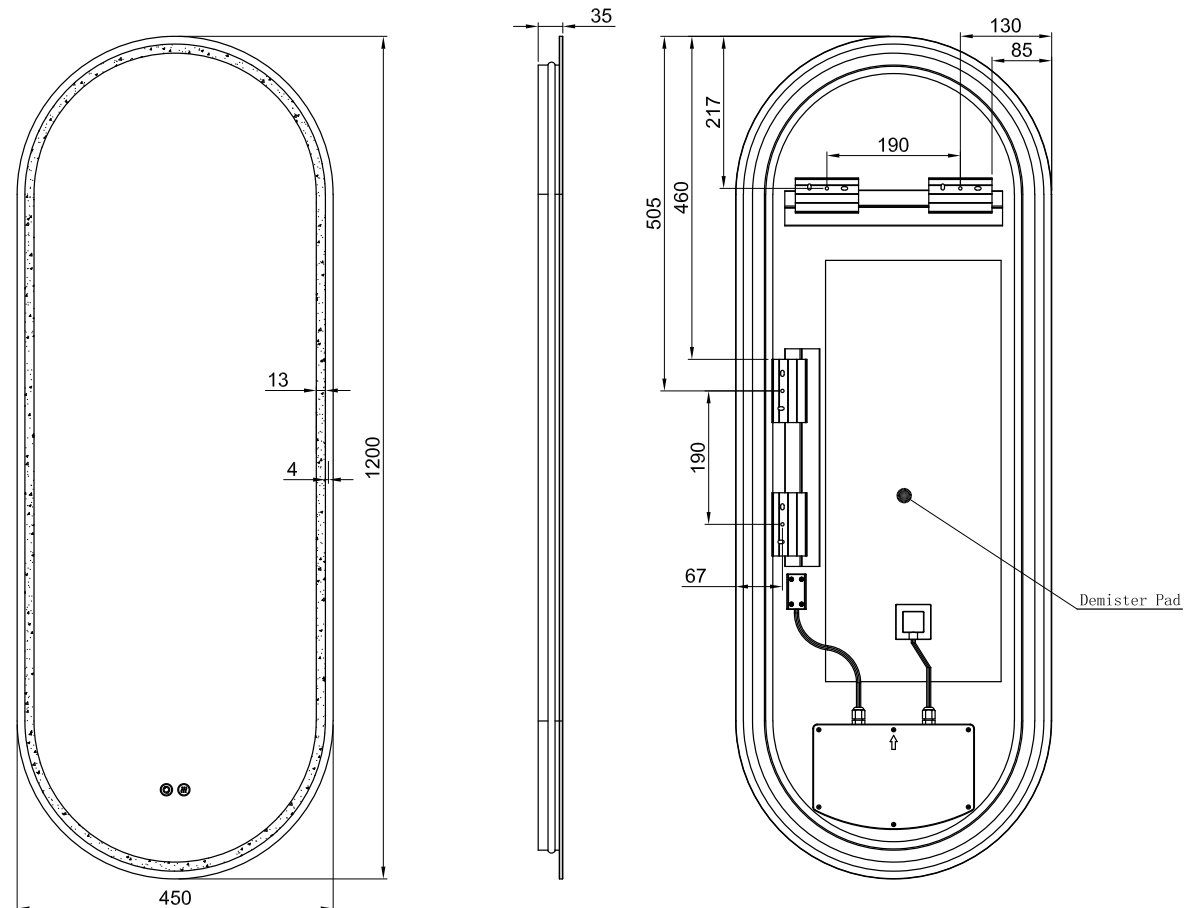

Disclaimer: All LED Products requiring hardwiring must be installed by a licensed electrician in accordance with local regulations. Sizes are in mm and nominal and should be checked prior to installation. Actual colours may vary so please check colour samples before ordering. Installation is acceptance of our products. Installation of faulty, warped, chipped or damaged products will void our warranty.

Please check actual product in box for bracket type used

GREAT GATSBY 450X1200D

LED MIRROR WITH ALUMINIUM FRAME

SPECIFICATIONS

WIDTH	455mm
HEIGHT	1205mm
DEPTH	40mm
WEIGHT	11kg
ORIENTATION	Portrait/Landscape

LIGHTING SPECIFICATIONS

CCT	2700K - 6500K
CRI	>80

INSTALLATION

Wall mount
Hardwire
Input voltage: 220-240v 50Hz

FEATURES

Copper Free Mirror
LED Lighting (Adjustable Colour Temperature)
Backlit
Touch Sensor
Demister with 1 Hour Auto Cut-off

FINISH		PRODUCT CODE
Brushed Brass		GG45120D-BB
Brushed Nickel		GG45120D-BN
Gun Metal		GG45120D-GM
Matte Black		GG45120D-MB
Matte White		GG45120D-MW

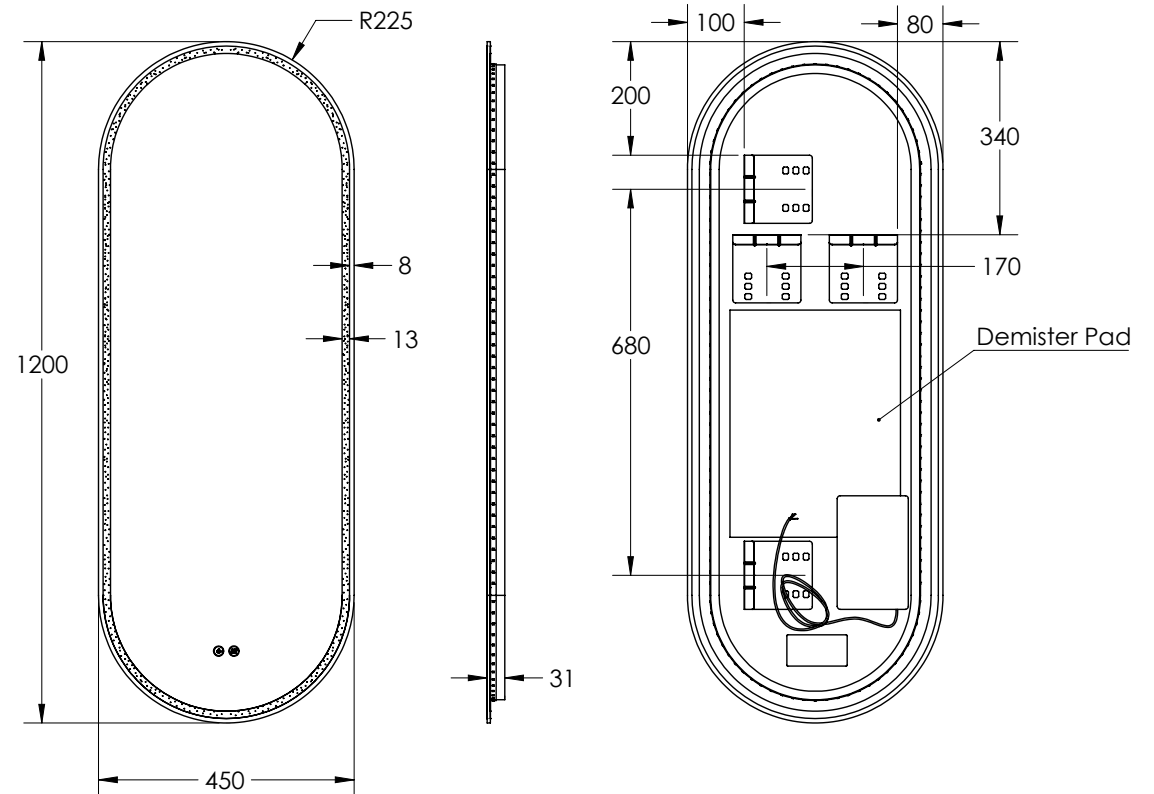

Disclaimer: All LED Products requiring hardwiring must be installed by a licensed electrician in accordance with local regulations. Sizes are in mm and nominal and should be checked prior to installation. Actual colours may vary so please check colour samples before ordering. Installation is acceptance of our products. Installation of faulty, warped, chipped or damaged products will void our warranty.

Please check actual product in box for bracket type used

GREAT GATSBY 450X1200D

LED MIRROR WITH ALUMINIUM FRAME

SPECIFICATIONS

WIDTH	455mm
HEIGHT	1205mm
DEPTH	40mm
WEIGHT	11kg
ORIENTATION	Portrait/Landscape

LIGHTING SPECIFICATIONS

CCT	2700K - 6500K
CRI	>80

INSTALLATION

Wall mount
Hardwire
Input voltage: 220-240v 50Hz

FEATURES

Copper Free Mirror
LED Lighting (Adjustable Colour Temperature)
Backlit
Touch Sensor
Demister with 1 Hour Auto Cut-off

FINISH		PRODUCT CODE
Brushed Brass		GG45120D-BB
Brushed Nickel		GG45120D-BN
Gun Metal		GG45120D-GM
Matte Black		GG45120D-MB
Matte White		GG45120D-MW

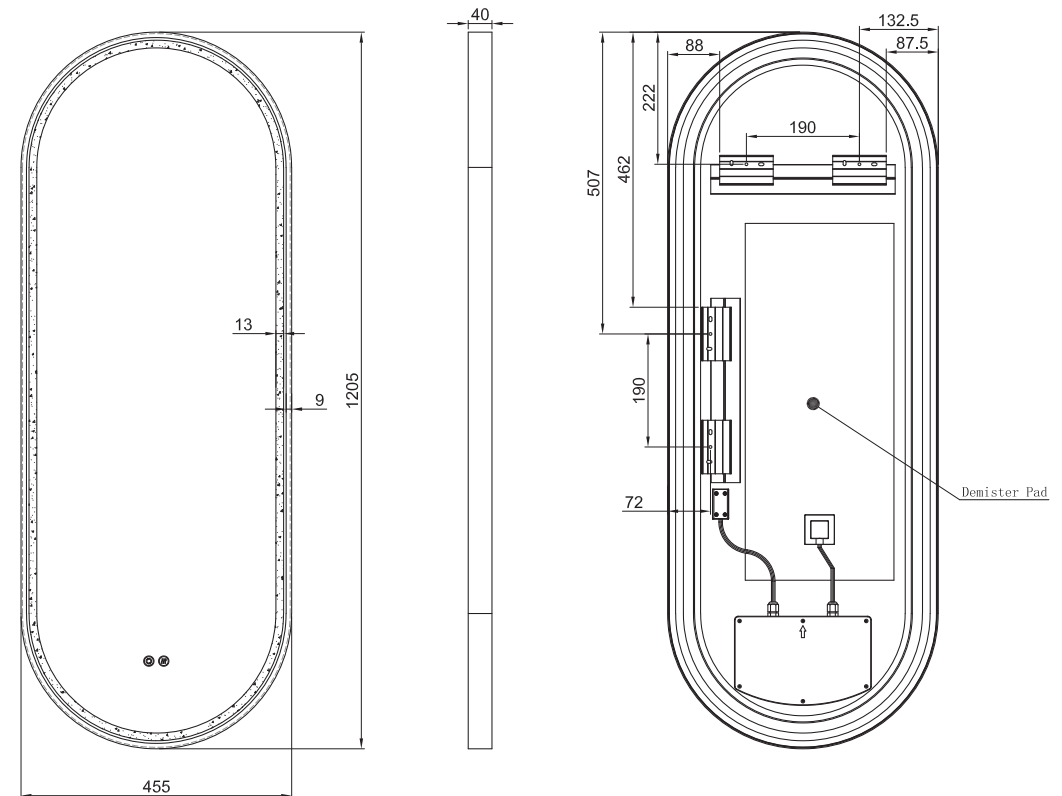

Disclaimer: All LED Products requiring hardwiring must be installed by a licensed electrician in accordance with local regulations. Sizes are in mm and nominal and should be checked prior to installation. Actual colours may vary so please check colour samples before ordering. Installation is acceptance of our products. Installation of faulty, warped, chipped or damaged products will void our warranty.