

Please check actual product in box for bracket type used

ARCH 500D

LED MIRROR

PRODUCT CODE
 AR50D

SPECIFICATIONS

WIDTH	500mm
HEIGHT	900mm
DEPTH	35mm
WEIGHT	7kg
ORIENTATION	Portrait

FEATURES

- Copper Free Mirror
- LED Lighting
(Adjustable Colour Temperature)
- Touch Sensor
- Demister with 1 Hour Auto Cut-off

LIGHTING SPECIFICATIONS

CCT	2700K - 6500K
CRI	>80

INSTALLATION

- Wall mount
- Hardwire
- Input voltage: 220-240v 50Hz

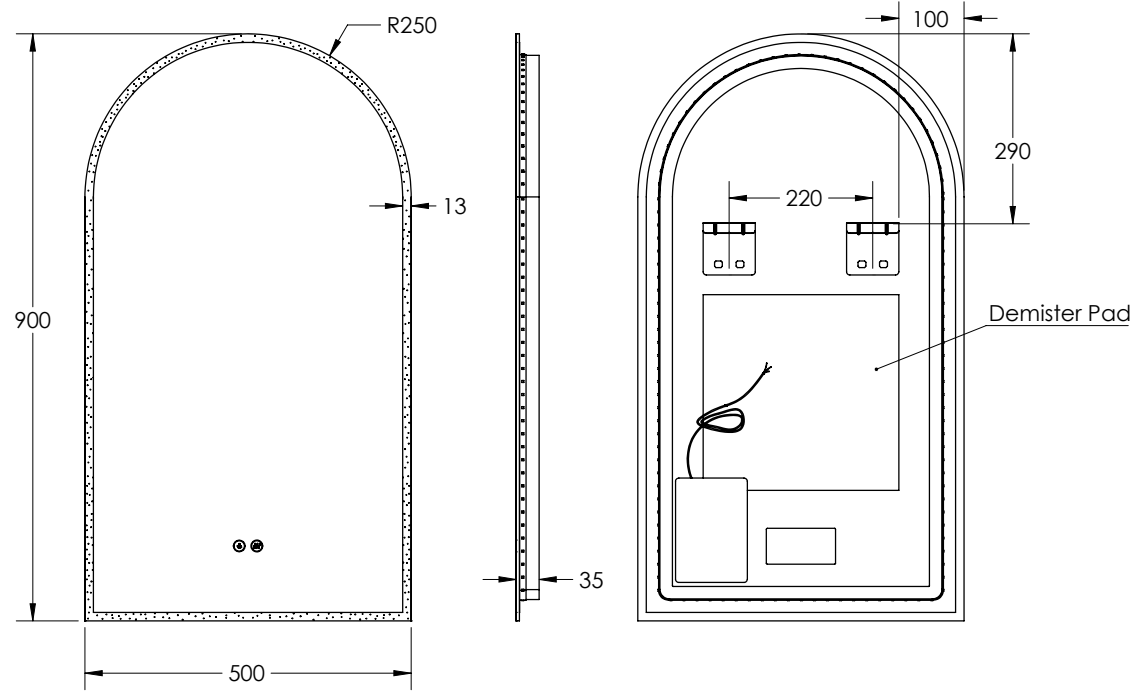

Disclaimer: All LED Products requiring hardwiring must be installed by a licensed electrician in accordance with local regulations. Sizes are in mm and nominal and should be checked prior to installation. Actual colours may vary so please check colour samples before ordering. Installation is acceptance of our products. Installation of faulty, warped, chipped or damaged products will void our warranty.

Please check actual product in box for bracket type used (Plug/Hardwire)

ARCH 500D

LED MIRROR

PRODUCT CODE
AR50D

SPECIFICATIONS

WIDTH	500mm
HEIGHT	900mm
DEPTH	35mm
WEIGHT	7kg
ORIENTATION	Portrait

FEATURES

- Copper Free Mirror
- LED Lighting
(Adjustable Colour Temperature)
- Touch Sensor
- Demister with 1 Hour Auto Cut-off

LIGHTING SPECIFICATIONS

CCT	2700K - 6500K
CRI	>80

INSTALLATION

- Wall Mount
- Plug or Hardwire
- Input Voltage: 220-240v 50Hz

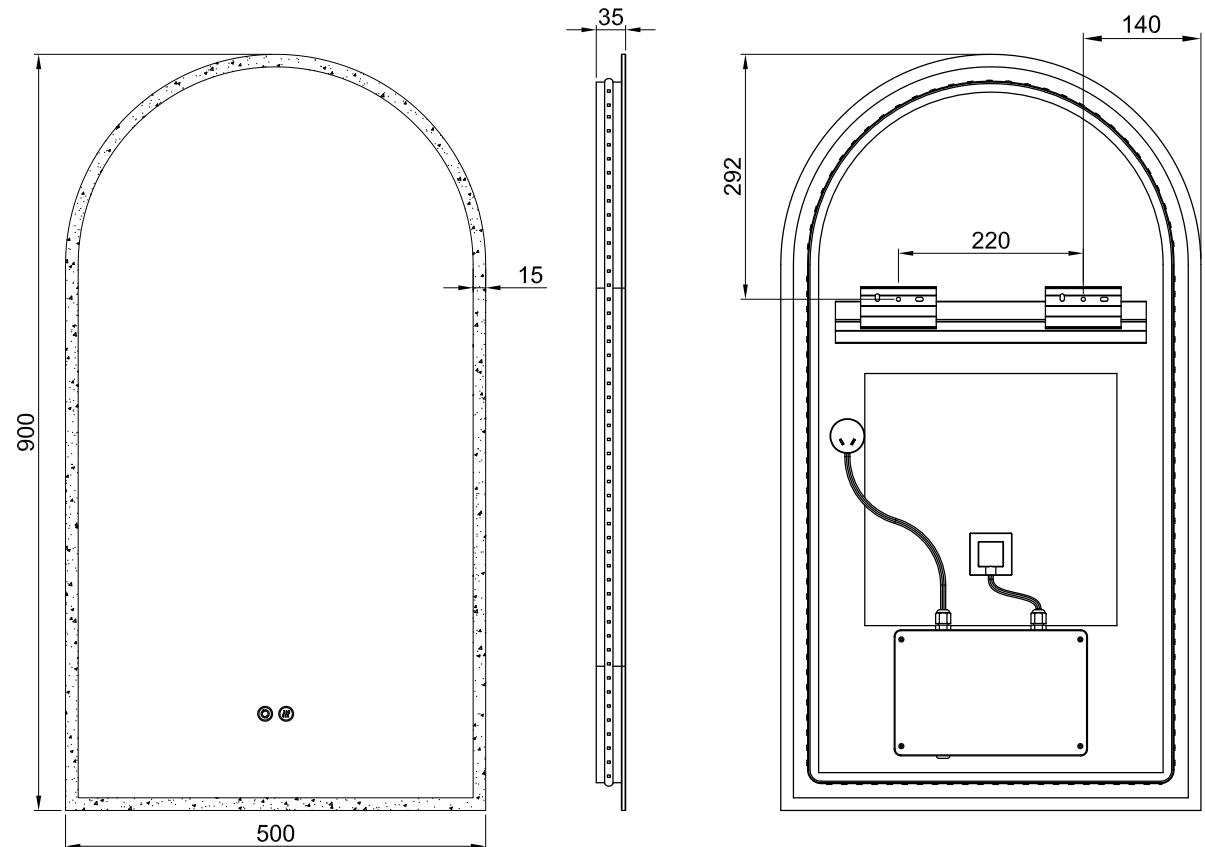

Disclaimer: All LED Products requiring hardwiring must be installed by a licensed electrician in accordance with local regulations. Sizes are in mm and nominal and should be checked prior to installation. Actual colours may vary so please check colour samples before ordering. Installation is acceptance of our products. Installation of faulty, warped, chipped or damaged products will void our warranty.

Please check actual product in box for bracket type used

ARCH 500D

LED MIRROR WITH ALUMINIUM FRAME

SPECIFICATIONS

WIDTH	510mm
HEIGHT	910mm
DEPTH	40mm
WEIGHT	8kg
ORIENTATION	Portrait

FEATURES

Copper Free Mirror
LED Lighting (Adjustable Colour Temperature)
Frontlit
Touch Sensor
Demister with 1 Hour Auto Cut-off

LIGHTING SPECIFICATIONS

CCT	2700K - 6500K
CRI	>80

INSTALLATION

Wall mount
Hardwire
Input voltage: 220-240v 50Hz

FINISH	PRODUCT CODE
Baltic Brass	AR50D-BB
Brits Nickel	AR50D-BN
Cuban Bronze	AR50D-CB
Georgian Metal	AR50D-GM

FINISH	PRODUCT CODE
Manhattan Black	AR50D-MB
Milano White	AR50D-MW
Nordic Gold	AR50D-NG

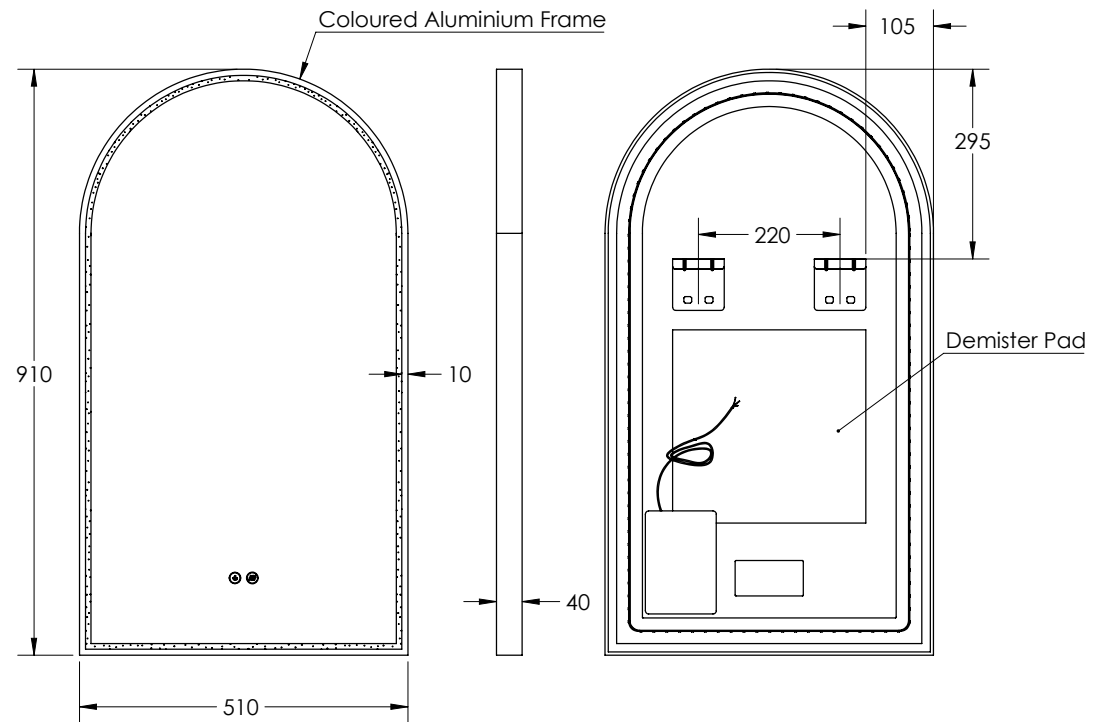

Disclaimer: All LED Products requiring hardwiring must be installed by a licensed electrician in accordance with local regulations. Sizes are in mm and nominal and should be checked prior to installation. Actual colours may vary so please check colour samples before ordering. Installation is acceptance of our products. Installation of faulty, warped, chipped or damaged products will void our warranty.

Please check actual product in box for bracket type used (Plug/Hardwire)

ARCH 500D

LED MIRROR

SPECIFICATIONS

WIDTH	505mm
HEIGHT	905mm
DEPTH	40mm
WEIGHT	8kg
ORIENTATION	Portrait

LIGHTING SPECIFICATIONS

CCT	2700K - 6500K
CRI	>80

INSTALLATION

Wall Mount
Plug or Hardwire
Input Voltage: 220-240v 50Hz

FEATURES

Copper Free Mirror
LED Lighting (Adjustable Colour Temperature)
Touch Sensor
Demister with 1 Hour Auto Cut-off

FINISH	PRODUCT CODE
Baltic Brass	AR50D-BB
Brits Nickel	AR50D-BN
Cuban Bronze	AR50D-CB
Georgian Metal	AR50D-GM

FINISH	PRODUCT CODE
Manhattan Black	AR50D-MB
Milano White	AR50D-MW
Nordic Gold	AR50D-NG

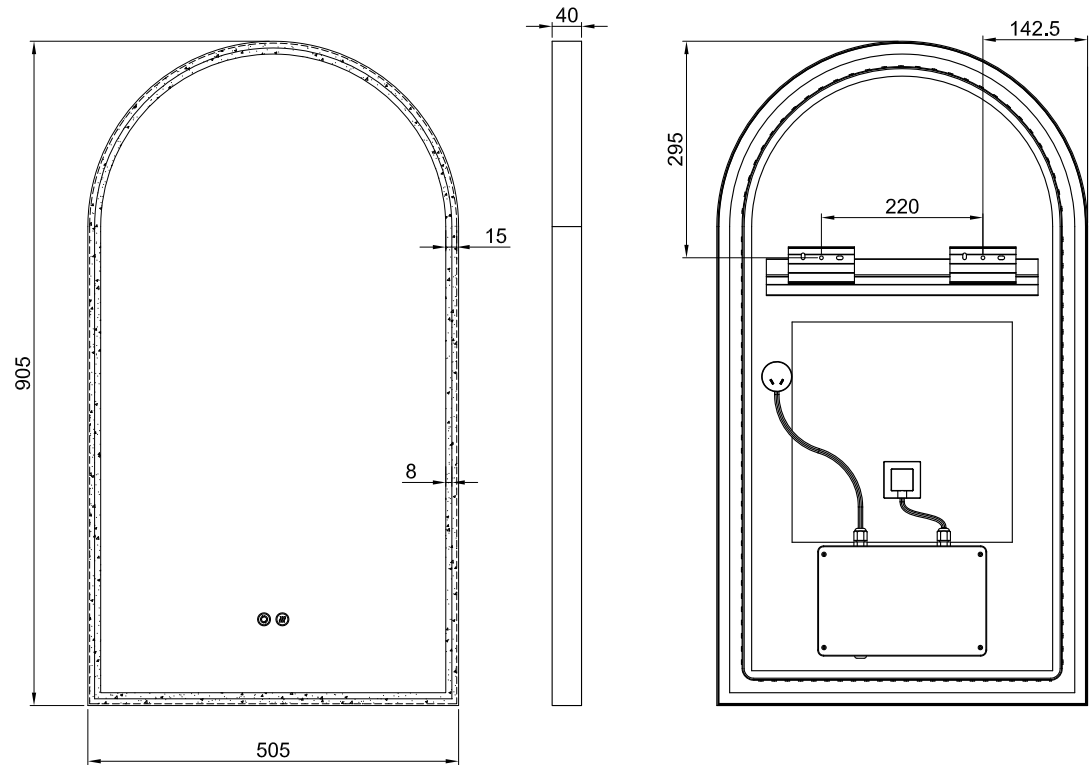

Disclaimer: All LED Products requiring hardwiring must be installed by a licensed electrician in accordance with local regulations. Sizes are in mm and nominal and should be checked prior to installation. Actual colours may vary so please check colour samples before ordering. Installation is acceptance of our products. Installation of faulty, warped, chipped or damaged products will void our warranty.