

Silver Brazed Barrel

16-14 WIRE RANGE

.032 Stock

The silver brazed barrel style terminals and connectors are the basic butted seam style with a brazed barrel seam. Bonded with a special silver brazing alloy, this seam cannot possibly open under any conditions of stress or wire pull. The silver brazed barrel is guaranteed not to split and may be crimped from any direction. It is truly versatile. It can be crimped by many different methods and many different kinds of tooling. Ideal for both difficult-to-crimp solid wires and for stranded wires.

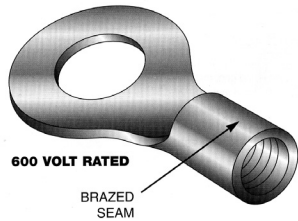









HEAVY DUTY TERMINALS made from 0.50" stock are designed to resist fractures under HEAVY vibration. Here is the best line of terminals for those extra difficult applications where RUGGEDNESS really counts!

Copper Solid and Stranded Wire Only

Terminals are NOT Actual Size See Sizing Chart on B-38, B-39

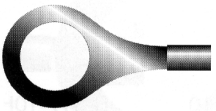
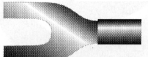
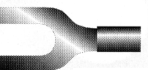

Stud Size	Part Number	Stud Size	Part Number
4-6	 R2B6S	4-6	 BS2B6
4-6	 R2B6	10	 BS2B10
6-8	 R2B8		 Butt B7B
8-10	 R2B10		
12-1/4	 R2B14S		
1/4-5/16	 R2B56S		
5/16-3/8	 R2B38		
4-6	 BS2B6S		
8	 BS2B8		

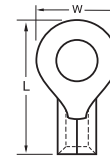

DIMENSIONAL CHART		
Part Number	W	L
B7B		0.656"
BS2B10	0.298"	0.607"
BS2B6	0.299"	0.606"
BS2B6S	0.251"	0.617"
BS2B8	0.313"	0.656"
P7B		0.293"
R2B10	0.344"	0.756"
R2B14S	0.469"	0.896"
R2B38	0.535"	1.084"
R2B56	0.530"	0.944"
R2B56S	0.462"	0.903"
R2B6	0.313"	0.704"
R2B6S	0.260"	0.560"
R2B8	0.313"	0.705"
R2B8S	0.251"	0.606"

Add suffix "M" for 1000 pack
Add suffix "P" for Pro Pack (Quantities vary by Part #)

Approved installation tool: See tool chart pages E-2,3,4
Economy installation tools: RAT-NINS, 453, HTS1000
See pages E-2 to E-4 for installation tools.

B