



# User Manual

19" Rack-mountable  
Active Receiver Multicoupler  
type

PRO-AR4G

PRO-AR8G

PRO-AR12G

PRO-AR16G

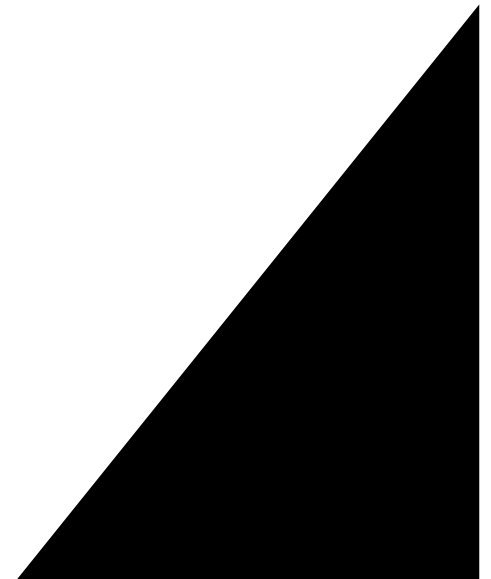

<b>Title:</b>				
User Manual for 19" Rack-mountable Active Receiver Multicoupler type PRO-AR...G (...: 4, 8, 12 or 16)				
<b>Document version:</b>				
Reviewed: 1r0				
Reviewed: 1r1				
Reviewed: 2r0				
Reviewed: 2r1				
Reviewed: 2r2				
Reviewed: 3r0				
<b>Document Change Record</b>				
Issue	Date	Sheet (s)	Description of change	Alterations endorsed and
1r0	23-05-2016	All	First release	SMN
1r1	05-05-2017	All	DC fuse size PRO-AR12G and PRO-AR16G	SMN
2r0	11-07-2017	All	Extended frequency range, document setup	SMN
2r1	18-10-2017	All	Power supply description, block diagram	SMN
2r2	17-05-2018	All	New Brand	JF
3r0	12-03-2025	All	115 V versions + floating DC power input added	SMN
<b>Procom Contacts:</b>				
Adnan Ahmad				
Director of Engineering			Customer service	
Phone: (+45) 48 27 84 84			Phone: (+45) 48 27 84 84	
Direct: (+45) 48 27 02 77				
<a href="mailto:aa@amphenolprocom.com">aa@amphenolprocom.com</a>			<a href="mailto:dksales@amphenolprocom.com">dksales@amphenolprocom.com</a>	

## EU and UK Declaration of Conformity

Hereby Amphenol Procom declare that the product type PRO-AR...G is in compliance with EU Directive 2014/53/EU and the UK Radio Equipment Regulations 2017 (S.I. 2017 No. 1206).

The full text of the Declaration of Conformity is available at:

<https://amphenolprocom.com/images/shop/catalog/pdf-for-catalogues/Declaration-of-Conformity-PRO-ARxG.pdf>

## List of Contents

1	Preface .....	3
2	Safety precautions .....	4
2.1	Environment .....	4
2.2	Protective earth.....	4
2.3	Equipotential bonding .....	4
2.4	Fuses.....	4
2.5	Power on/off .....	4
2.6	Reading this manual .....	4
3	Introduction .....	5
4	Technical Specifications.....	5
5	Block Diagrams.....	5
5.1	Block diagram PRO-AR4G.....	5
5.2	Block diagram PRO-AR8G.....	6
5.3	Block diagram PRO-AR12G.....	6
5.4	Block diagram PRO-AR16G.....	7
6	Circuit description .....	7
6.1	Amplifier/splitter modules .....	7
6.2	Preselector (option) .....	8
6.3	Power supply .....	8
6.3.1	Power supply Block Diagram .....	9
6.4	Power supply backup function .....	9
7	Installation.....	9
7.1	Front view .....	9
7.2	Rear view.....	10
7.2.1	Rear view PRO-AR4G .....	10
7.2.2	Rear view PRO-AR8G .....	10
7.2.3	Rear view PRO-AR12G .....	10
7.2.4	Rear view PRO-AR16G .....	11
7.3	Connection of power supply voltage .....	11
7.3.1	Mains power connection .....	11
7.3.2	Protective earth.....	11
7.3.3	DC power connection.....	11
7.3.4	Floating DC power input .....	12
7.4	Equipotential bonding .....	12
7.5	Connection of antenna.....	12
7.6	Connection of receivers .....	13
7.7	Mounting.....	13
8	Operating instructions .....	13
8.1	Power on LED.....	13
8.2	Maintenance .....	13
9	Trouble shooting .....	13
9.1	Spare parts .....	14

### 1 Preface

This user manual covers the Procom Active Receiver Multicoupler models: PRO-AR4G, PRO-AR8G, PRO-AR12G, and PRO-AR16G.

In the subsequent chapters, for the sake of clarity:

Where the descriptions are valid for all 4 receiver multicoupler models, the figure in the model designation is replaced by "...", as example: PRO-AR...G.

## 2 Safety precautions

This equipment is not suitable for use in locations where children is likely to be present.

### 2.1 Environment

The PRO-AR...G is intended for indoor use only.

Do not allow the unit to be wet.

Do not operate the unit at temperatures outside the specified range -10 °C to +50 °C.

Do not place the unit in a corrosive environment.

### 2.2 Protective earth

The main earthing point is the center contact of the IEC60320-1 C14 mains power inlet. See chapter 7.2, 7.3 and 7.3.2.

Connection to protective earth is provided via the 3-wire IEC mains power cord.

As safety relies on connection to protective earth,

*the PRO-AR...G must be connected to an earthed mains socket-outlet.*

### 2.3 Equipotential bonding

It is strongly recommended that all interconnected conductive accessible parts in a system are connected to an equipotential bonding system.

The center terminal of the 3 pole screw terminal block on the rear side is intended for equipotential bonding. See chapter 7.2 and 7.4.

### 2.4 Fuses

Individual fuses are provided for both the mains voltage and the DC voltage.

The fuse holders are located on the rear side next to the supply voltage connectors.

On the top plate next to the fuse holders are marked the fuse specifications.

*To maintain the safety level, a blown fuse must be replaced by a fuse of equal size, type and value. Refer to chapter 9.1: "Spare parts".*

### 2.5 Power on/off

No power on/off switch is provided on the PRO-AR...G.

Therefore, as soon as power is connected, the equipment will be immediately active and the green power on LED on the front plate will light, indicating power is on.

The mains power cord (mains plug or socket) serves as a mains switch and *either plug or socket of the cord must be easily accessible.*

### 2.6 Reading this manual

Before installing or replacing of the PRO-AR...G, this entire manual should be read and understood. Incorrect installation and usage may damage the equipment.

### 3 Introduction

The typical function of an active receiver multicoupler is to distribute a received antenna signal to a number of receivers, *without introducing any signal loss and interacting between the receivers.*

A passive power splitter *could* be used to split the antenna signal for the required number of receivers. However, this way each receiver will only get a part of the received signal power, and the sensitivity of the individual receivers will be reduced.

If an active low-noise receiver multicoupler is used for antenna signal distribution, an antenna signal virtually identical to the original one will be applied to each receiver, as if the particular receiver was directly connected to the antenna exclusively.

This manual contains description, installation and documentation of the PROCOM types PRO-AR4G, PRO-AR8G, PRO-AR12G and PRO-AR16G, which are active receiver multicouplers with one input (ANT) intended for connection of RF signal (antenna signal) and 4, 8, 12 or 16 identical outputs (RX1 to RX4/8/12/16) intended to provide RF signal (antenna signal) for a similar number of individual receivers.

PRO-AR...G series covers the frequency range 30 MHz to 960 MHz and can be used at any frequency or frequency band within this range.

The PRO-AR...G multicouplers can also be used for buffering and splitting any other kind of RF signal within the specified signal dynamic range of the equipment.

### 4 Technical Specifications

Please refer to the PRO-AR...G datasheet on [www.amphenolprocom.com](http://www.amphenolprocom.com)

### 5 Block Diagrams

#### 5.1 Block diagram PRO-AR4G

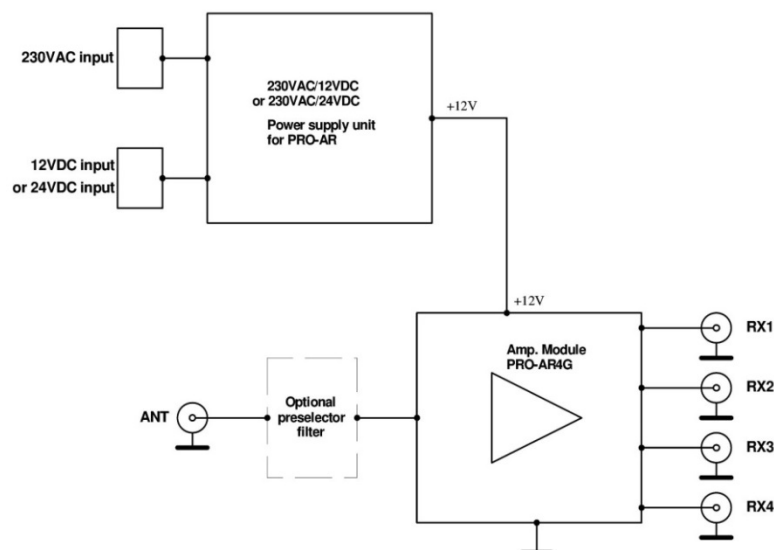

### 5.2 Block diagram PRO-AR8G

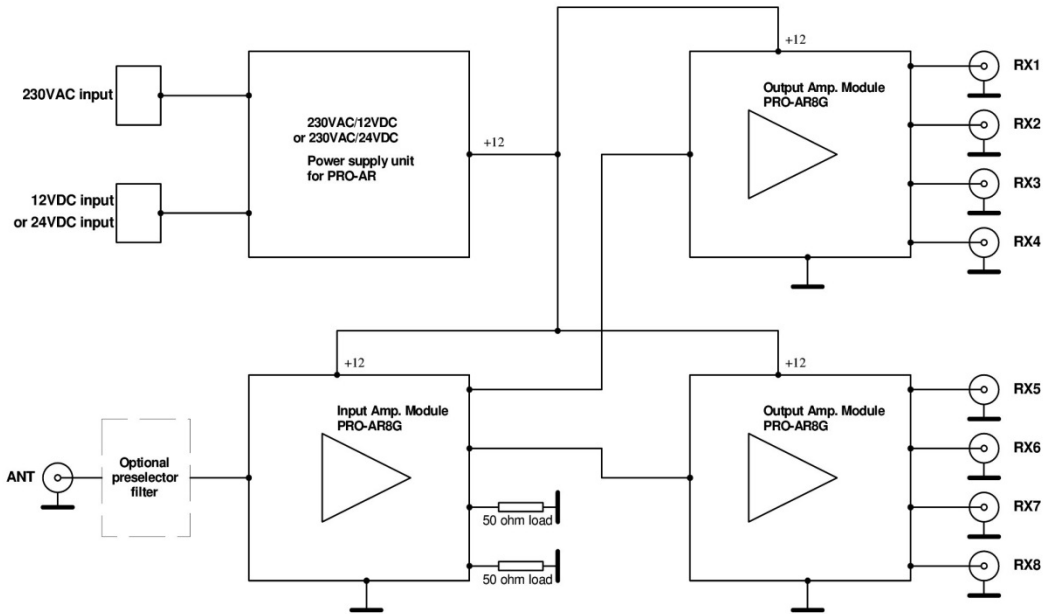

### 5.3 Block diagram PRO-AR12G

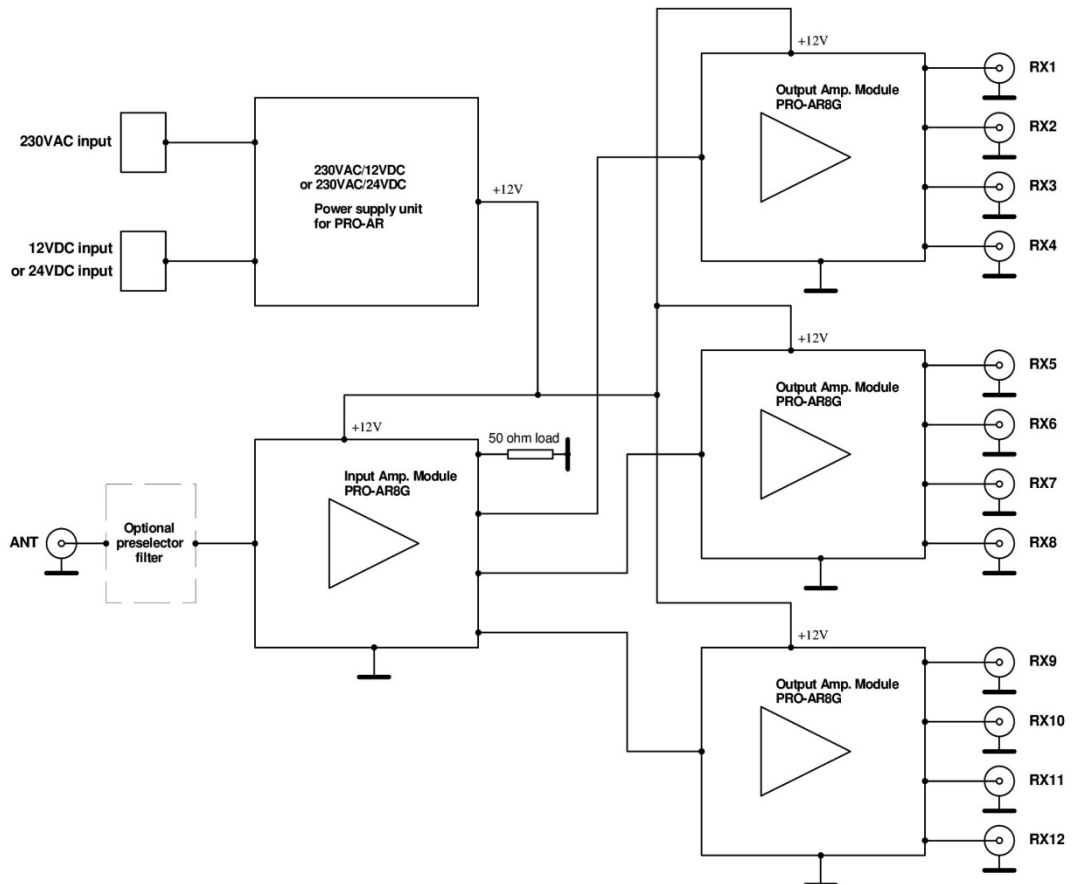

## 5.4 Block diagram PRO-AR16G

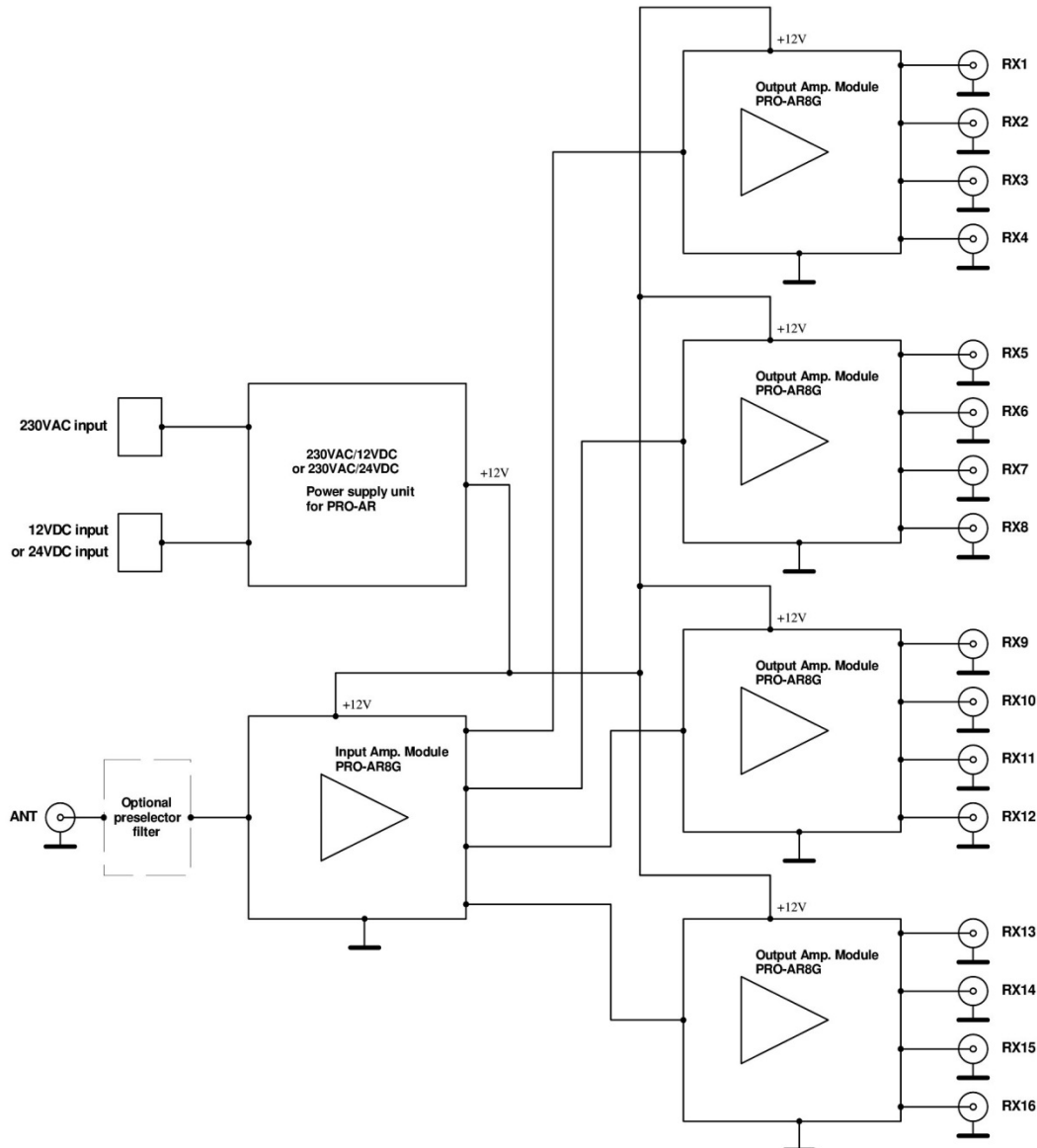

## 6 Circuit description

### 6.1 Amplifier/splitter modules

The PRO-AR...G multicoupler contains a dedicated RF amplifier system, and a power splitter circuitry corresponding to the particular number of outputs.

The amplifier system compensates for the n-way splitter loss + circuitry insertion loss.

In PRO-AR4G, the ANT signal feeds an amplifier, which is provided with a 4-splitter circuitry at the output. The outputs from the splitter form the 4 identical RX outputs.

In PRO-AR8G, 12G and 16G, the ANT input signal feeds an input amplifier, which again is driving 2, 3 or 4 identical output amplifiers.

These are all provided with a 4-splitter circuitry which divides the output signal into 4 identical signals, thus forming in all 8, 12 or 16 identical RX outputs.

The power splitter circuitry is of the Wilkinson type and provides high isolation between the individual RX outputs, ensuring insignificant low mutual coupling between the connected receivers.

See chapter 5: Block diagrams.

The RF amplifiers have low noise figure to ensure lowest possible signal-to-noise ratio deterioration of the distributed RX signal.

Simultaneously, the amplifiers have very good large signal capabilities, in order to avoid intermodulation between strong signals in the distributed RF signal spectrum.

In order to maintain a high input dynamic range of the connected receivers (ability to withstand strong antenna signals), RF gain from ANT input to RX output is selected to be low, nominally +2 dB.

This gain value is factory adjusted and gain adjustment is not user accessible.

Amplifier and power splitter circuitry are of wideband structure, meaning that signals in the whole frequency range from 30 MHz to 960 MHz will be amplified equally.

## 6.2 Preselector (option)

If the receiver multicoupler shall work within a narrower specified frequency band, it will be advantageous to insert a preselector filter with pass range equal to the frequency band of interest between the multicoupler ANT input and the amplifier.

The preselector filter will allow the wanted frequency band to pass and simultaneously attenuate all signals outside this band, thus reducing the risk of possible interference from strong unwanted out-of-band signals.

If desired, the PRO-AR...G can be ordered with a factory built-in custom specified preselector filter. PROCOM A/S offers a large number of standard low-loss filters, which are suitable as multicoupler preselector.

An overview of available preselector filters is found on the PRO-AR...G data sheet on [www.amphenolprocom.com](http://www.amphenolprocom.com)

## 6.3 Power supply

The PRO-AR...G is provided with a power supply unit which supplies DC voltage for the amplifier modules.

The power supply unit both can operate with 230 or 115 VAC mains voltage and with 12 or 24 or 48 VDC, depending on model.

The AC mains voltage directly feeds a mains voltage winding on the mains transformer, The DC voltage feeds a 50 Hz power multivibrator circuitry, which supplies a 50 Hz square wave to a low voltage winding on the mains transformer.

Another low-voltage winding feeds AC voltage to a rectifier and voltage regulator circuitry.

The voltage regulator output supplies 12 VDC to the RF amplifier module.

As both the mains supply voltage *and* the DC supply voltage thus are fully galvanically separated from the amplifier supply voltage by the mains transformer, unwanted ground loops etc. are avoided.

### 6.3.1 Power supply Block Diagram

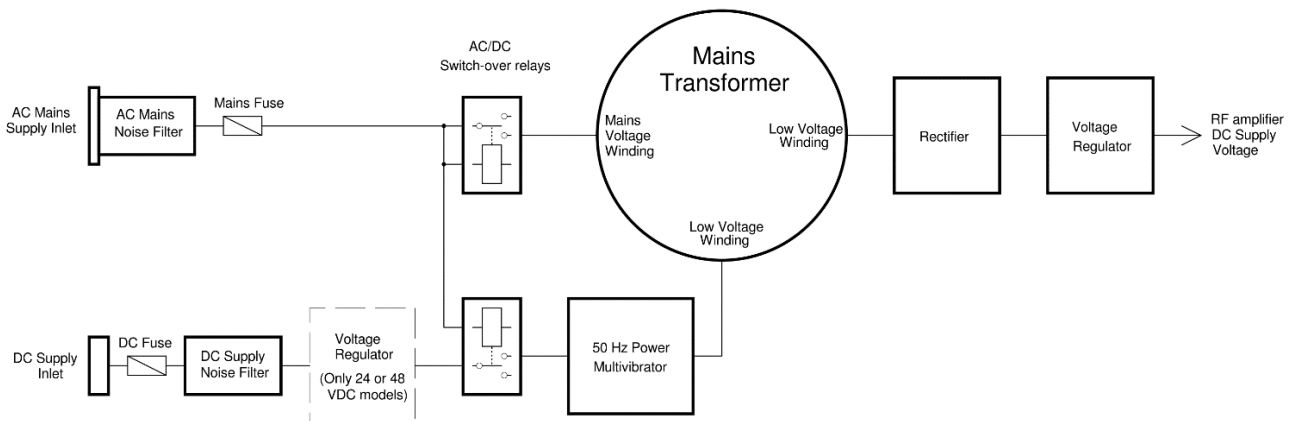

### 6.4 Power supply backup function

The power supply unit is provided with backup function.

If DC voltage (12, 24 or 48 VDC depending on model) from e.g., a rechargeable battery is connected to the multicoupler *together with AC mains voltage*, the DC voltage source will function as power backup.

If AC mains supply voltage is applied to the multicoupler, the relays are activated and the relay contact setting will connect mains voltage to the transformer and the DC supply voltage input will be switched off.

The mains voltage thus have priority, and the multicoupler will operate on the mains voltage if present, independent of DC voltage is connected or not.

If the mains voltage falls out, the relays are deactivated, and the contact setting will disconnect the mains voltage input and connect DC supply voltage to the power multivibrator, which then feeds low-voltage AC to a separate winding on the transformer, and the multicoupler will continue to operate.

This automatic power switch-over function thus ensures an uninterrupted service of the multicoupler, in case of mains power outage.

The multicoupler can of course also operate directly on the DC supply voltage only, if no mains supply voltage is connected.

## 7 Installation

### 7.1 Front view

The front plate is identical on all 4 receiver multicoupler models, except for the height: PRO-AR4G and PRO-AR8G are 1HU (44.45 mm) high. PRO-AR12G and PRO-AR16G are 2HU (89.9 mm) high.

The front plate is provided with 2 pcs. 7 x 10 mm oval mounting holes in each side, intended for rack mounting of the multicoupler, using M6 screws. Further, a green power on LED is provided.

**Front view of PRO-AR4G/PRO-AR8G:**

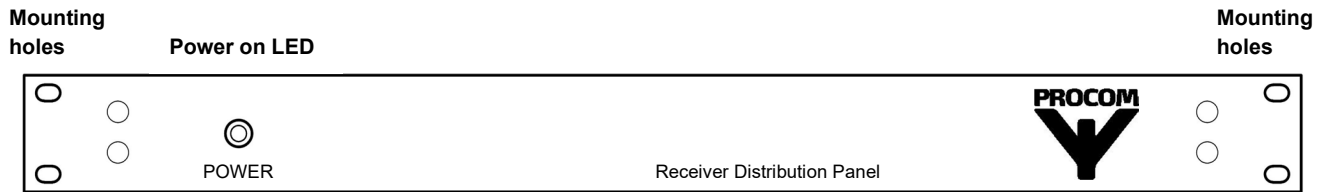

**7.2 Rear view**

The rear panel of the multicouplers is provided with ANT and RX RF connectors, mains power and DC power inlets, and holders for both mains and DC fuses. Below is shown the rear view of the 4 multicoupler models:

**7.2.1 Rear view PRO-AR4G**

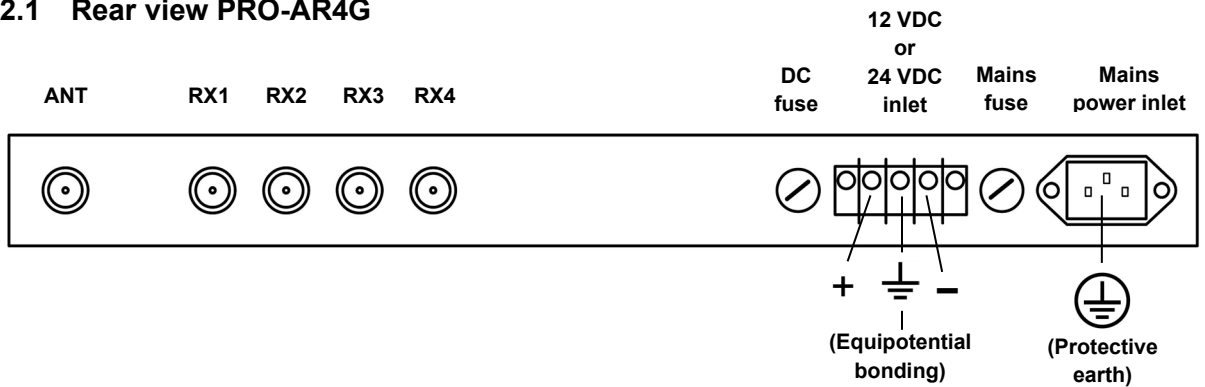

**7.2.2 Rear view PRO-AR8G**

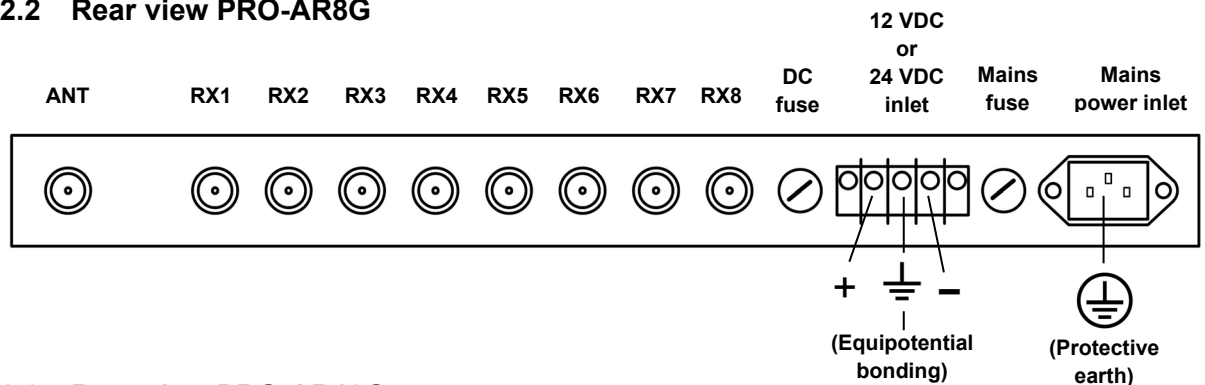

**7.2.3 Rear view PRO-AR12G**

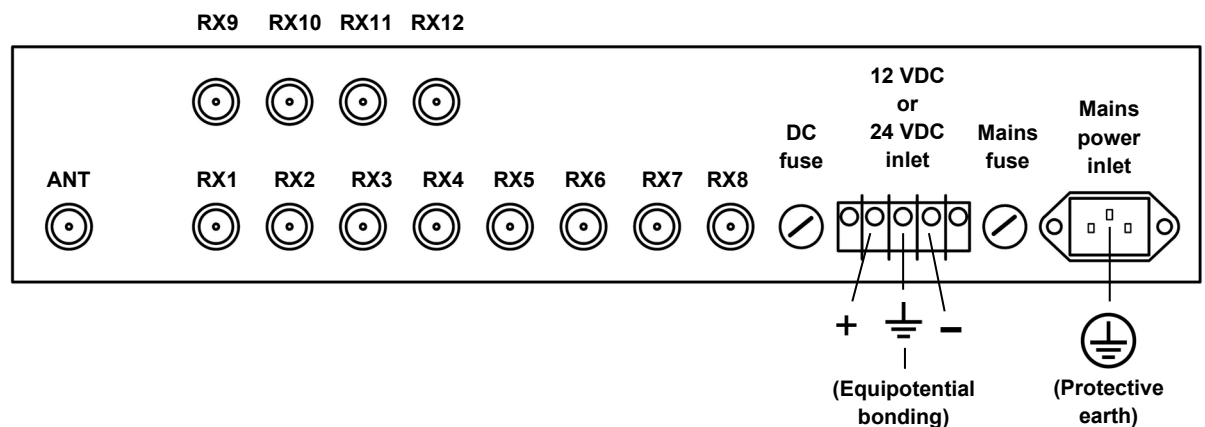

## 7.2.4 Rear view PRO-AR16G

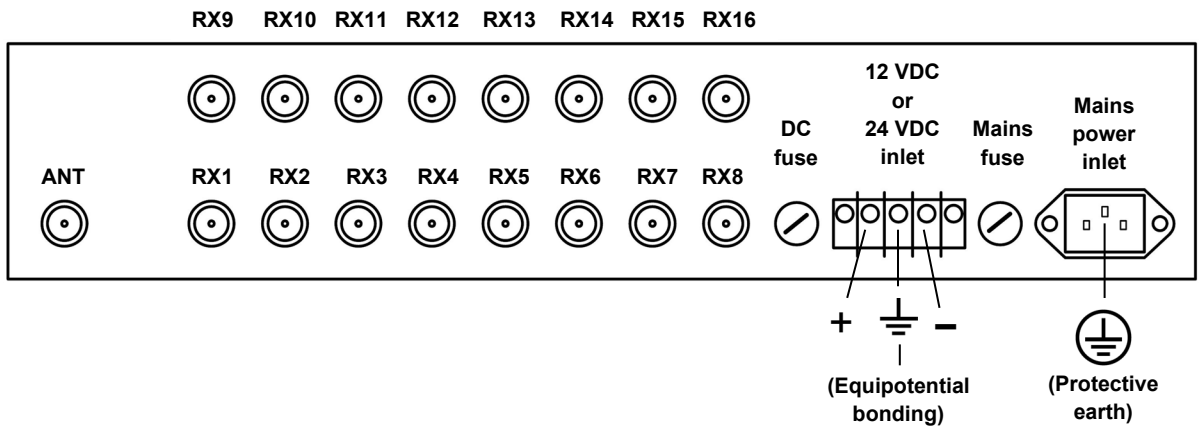

## 7.3 Connection of power supply voltage

### 7.3.1 Mains power connection

The PRO-AR...G is provided with a 3-terminal IEC60320-1 C14 (male) inlet for mains power connection. The mains inlet is located on the rear side. See rear view above. Applied mains voltage must be within the range 198 – 264 VAC (220 – 240 V ±10 %) and the AC frequency must be within 47 to 63 Hz.

A 3-wire IEC power cord must be used for mains voltage connection.

### 7.3.2 Protective earth

The main earthing point is the center contact of the mains power inlet. See PRO-AR...G rear view above.

Connection to protective earth is provided via the 3-wire IEC power cord.  
*The PRO-AR...G, therefore must be connected to an earthed mains socket-outlet.*

### 7.3.3 DC power connection

The PRO-AR...G is provided with a 3 pole screw terminal block (DC inlet) for connection of 12 VDC voltage or 24 VDC voltage (depending on model). The terminal block is located on the rear side. See rear view above.

Applied DC voltage must be within the range:

12 VDC models:	10.8 – 14.4 VDC
24 VDC models:	20 – 32 VDC
48 VDC model (only PRO-AR4G):	40 – 60 VDC

On the top plate next to the screw terminal block are indicated the polarity of the screw terminals:

+    ⏏    -

DC supply voltage (if used) must be applied correctly to the receiver multicoupler. If the polarisation of the applied DC voltage is wrong, the DC fuse will blow. The fuse must be replaced by a fuse according to chapter 9.1: “Spare parts”.

### 7.3.4 Floating DC power input

The DC power input is floating, which means that both the + and the – terminal are internally isolated from ground.

This means that the DC power input *can operate with both positive and negative supply voltage* referred to ground.

#### Example 1:

If the PRO-AR...G 24V model shall operate on +24 VDC, the positive wire shall be connected to the “+” terminal in the DC connector.

The negative wire *and the ground connection* shall be connected to the “– “ terminal.

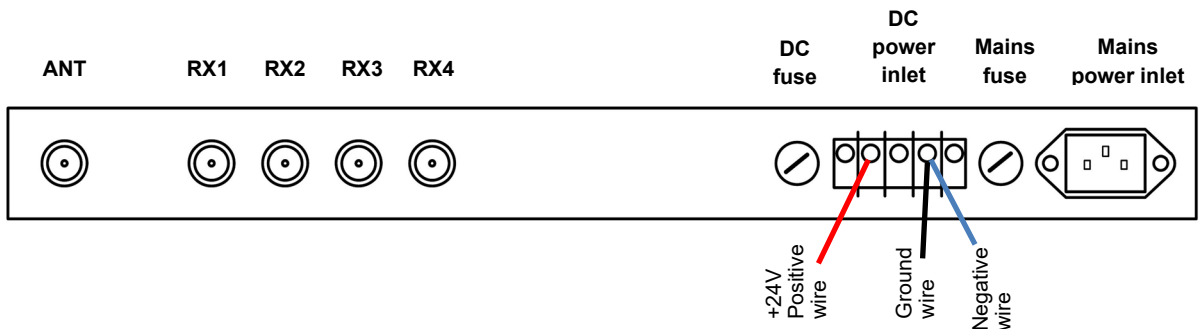

#### Example 2:

If the PRO-AR...G 12V model shall operate on -12 VDC, the positive wire *and the ground connection* shall be connected to the “+” terminal in the DC connector.

The negative wire shall be connected to the “– “ terminal.

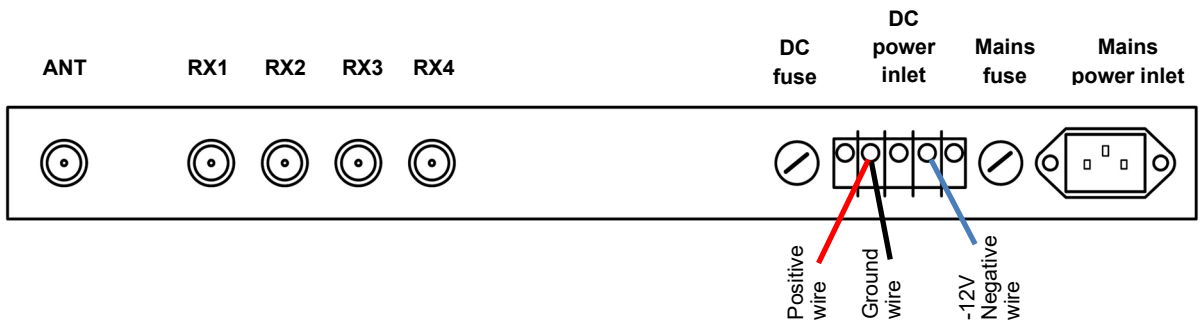

## 7.4 Equipotential bonding

The center terminal of the 3 pole terminal block marked is intended for equipotential bonding.

It is strongly recommended that all interconnected conductive accessible parts in a system are connected to an equipotential bonding system, in order that no hazardous touch voltage appears on exposed conductive parts.

## 7.5 Connection of antenna

The antenna (or other RF source) shall be connected to the input connector marked “ANT” on the rear edge of the receiver multicoupler top plate by means of a suitable coax cable.

*Be aware that the maximum RF input level of +18 dBm is not exceeded, in order to avoid damaging of the RF amplifier.*

As the ANT connector shield is connected to chassis, the coax cable shield will automatically be included in the equipotential bonding (if used).

## 7.6 Connection of receivers

The individual receivers' antenna inputs (RF inputs) shall be connected by a suitable coax cable to the output connectors marked "RX1 to 4", "RX1 to 8" "RX1 to 12" or "RX1 to 16" (depending on model) on the rear edge of the receiver multicoupler top plate. If the receiver multicoupler has unused RX output ports, these shall be terminated with a 50  $\Omega$  dummy load (min. 250 mW).

## 7.7 Mounting

By rack mounting, screws must be mounted in all 4 mounting holes in the front plate.

When mounted in a fully enclosed cabinet,  
*adequate ventilation or heat path shall be provided*  
in order to keep the air temperature round the multicoupler housing below +50 °C.

# 8 Operating instructions

As soon as mains supply voltage or DC supply voltage is applied to PRO-AR...G, it will be immediately active.  
Normal operational conditions do not require any adjustments or settings of the multicoupler.

## 8.1 Power on LED

When power is connected to the PRO-AR...G, the green power on LED on the front plate will immediately light and indicate the multicoupler is active.

## 8.2 Maintenance

No maintenance of the PRO-AR...G is normally needed.  
However, if any malfunction of the multicoupler occurs, please refer to chapter 9: "Trouble shooting" below.

If the instructions in the Trouble shooting chapter is insufficient, please contact nearest PROCOM dealer or PROCOM A/S for further information.

# 9 Trouble shooting

Symptom	Possible cause	Action
Power on LED off	Supply voltage not connected or off.	Connect supply voltage.
	By DC voltage operation, wrong DC polarity.	Check DC voltage and polarity and reverse connections if necessary.
	AC or DC fuse blown.	Check and replace fuse(s).
Reduced receiver sensitivity	Supply voltage not connected or off.	Connect supply voltage.

	AC or DC fuse blown, power on LED off	Replace fuse(s).
Other fault symptoms		Contact PROCOM A/S.

## 9.1 Spare parts

Article	Value	Amphenol Procom Spare part no.
Fuse for 230 VAC	T315mAL250V 5x20 mm	661001008
Fuse for 115 VAC	T500mAL250V 5x20 mm	661001096
Fuse for 12 VDC/24 VDC	T2AL250V 5x20 mm	661000047
Fuse for 48 VDC	T315mAL250V 5x20 mm	661001008