



MINI DUCT HUNTER™

Part Number	Rod Diameter	Length	Recommended Conduit Size
15-18-100	1/8"	100'	1/2" - 1"
15-18-150	1/8"	150'	1/2" - 1"
15-18-200	1/8"	200'	1/2" - 1"
15-18-250	1/8"	250'	1/2" - 1"
15-18-300	1/8"	300'	1/2" - 1"
15-316-100	3/16"	100'	1/2" - 1-1/2"
15-316-150	3/16"	150'	1/2" - 1-1/2"
15-316-200	5/16"	200'	1/2" - 1-1/2"
15-316-250	5/16"	250'	1/2" - 1-1/2"
15-316-300	5/16"	300'	1/2" - 1-1/2"

- Locate Fiber Optic Cables In Plastic Pipe Without Tracer Wire
- Fiber To The Home Applications - Locate Fiber Optic Micro-Duct
- Plumbing Applications - Fiberglass Will Not Rust
- Trace Sewer Laterals (Up To 4" In Diameter) To Avoid Cross Bores
- Includes Accessory Kit



⚠️ WARNING

- **DO NOT USE ON LIVE CIRCUITS. DISCONNECT POWER.** Metal tip on rod.
- Wear safety glasses and gloves.
- Keep rod inside reel when not in use. Out-of-control rod can harm personnel or property.
- Keep rod clean. Some contaminants (including water) can conduct electricity.
- Keep secure footing. Protect yourself from falling should pulling eye move suddenly or separate from rod.
- Check for rod damage prior to use. Cracks, gouges, nicks, or white stress marks on jacket or sharp bends will weaken rod. Injury could result if rod breaks while pulling.
- Do not use slip joint pliers, locking pliers or powered pulling equipment on rod.
- Do not force a pull that is stuck. Check for kinks or obstructions.
- Avoid pulling rod over sharp edges.
- Do not bend rod beyond 6" radius.

⚠️ WARNING - ADHESIVE

Read manufacturer's instructions before using adhesive. In case of eye contact, flush with water and seek medical attention. If skin contact occurs, apply solvent (such as nail polish remover) to area and gently remove adhesive. Wash solvent off with water. Solvents should not be used in case of contact with eyes or open wounds. Always wear safety goggles (ANSI Std. Z87.1) and gloves when working with adhesive and/or unprotected fiberglass rod. See adhesive product label for Safety Data Sheet (SDS).

WARRANTY

Jameson products carry a warranty against any defect in material and workmanship for a period of one year from date of shipment unless failure is due to misuse or improper application. Jameson shall in no event be responsible or liable for modifications, alterations, misapplications or repairs made to its products by purchaser or others. This warranty is limited to repair or replacement of the product and does not include reimbursement for shipping or other expenses incurred. Jameson disclaims any other express or implied warranty.

Accessories



1 Flexible Leader with Ball Tip

1 End Ferrule

1 Splice Ferrule

2 Adhesive

2 Emery Cloth

1 Shrink Tube

1 Canvas Storage Pouch (Mounts on Reel)

Part Number	Accessories	Description
15-163	Flexible Leader with Ball Tip	Guides rod around bends, sweeps, misalignments and wires. Fits 1/8" and 3/16" Rod
15-146	3/16" End Ferrule Repair Kit	End Ferrule, Adhesive, Emery Cloth
15-140	3/16" Splice Repair Kit	Splice Ferrule, Adhesive, Shrink Tube, Emery Cloth
15-160	Pulling Eye	Attaches to end fitting of rod so pull line can be attached to rod. Fits 1/8" and 3/16" Rod
15-18-146	1/8" End Ferrule Repair Kit	End Ferrule, Adhesive, Emery Cloth, Instructions
15-18-140	1/8" Splice Repair Kit	Splice Ferrule, Adhesive, Shrink Tube, Emery Cloth, Instructions
15-316-AK	3/16" Accessory Kit	Flexible Spring Leader Tip, End Ferrule, Splice Ferrule, Pulling Eye, Adhesive, Emery Cloth, Canvas Pouch
15-18-AK	1/8" Accessory Kit	Flexible Spring Leader Tip, End Ferrule, Splice Ferrule, Pulling Eye, Adhesive, Emery Cloth, Canvas Pouch
15-168	Sonde Adapter	Heavy Duty Flexible Adapter with Chain, Fits 3/8" and 1/2" Buddy Rodders; 5/16" and 7/16" Duct Hunters. Fits 14-169 Sonde
14-169	Sonde	Solid Adapter, Fits Sonde and 3/8", 1/2", 5/16", 7/16" Rod

Accessories - Sold Separately

Mini Duct Hunter Operation

1. Operates in upright or horizontal position. If used in horizontal position, safety roller guides and brake control handle should be on top side.
2. Set drag brake to highest amount of drag (Fig. 1).
3. Insert end of fiberglass rod between the upper and lower nylon safety roller guides (Fig. 2). This ensures duct rod will be safely contained while working with it.
4. Release pressure on drag brake handle so rod will begin to slowly payout from reel.
5. Brake may be set for constant drag on payout of rod. The constant drag makes one-man operation possible. Fully tightening brake handle stops payout of rod. For constant drag and controlled payout, set brake handle where reel turns only as you pull out rod.
6. Pay out rod into underground facility. Lock brake handle.
7. Attach signal output lead from your transmitter to brass end ferrule on clip attachment (Fig. 3). Attach ground lead to desired ground mechanism.
8. Follow your transmitter's operating instructions to apply the desired signal frequency to the rod.*
9. Use your receiver to trace the path of the rod following the instructions of your receiver.
10. If further rod payout is required, detach transmitter output lead, loosen drag brake and pay out more rod. Lock brake handle and re-attach transmitter output lead.
11. When recoiling rod, detach transmitter lead, loosen drag brake and **push rod back onto reel**. Allow reel to spin only when pushing rod. Do not manually spin reel in an attempt to reel up rod.

* Always follow the manufacturer's instructions and precautions when using your transmitter and receiver. Jameson is not responsible for damage or injury as a result of improper use of your transmitter or receiver.

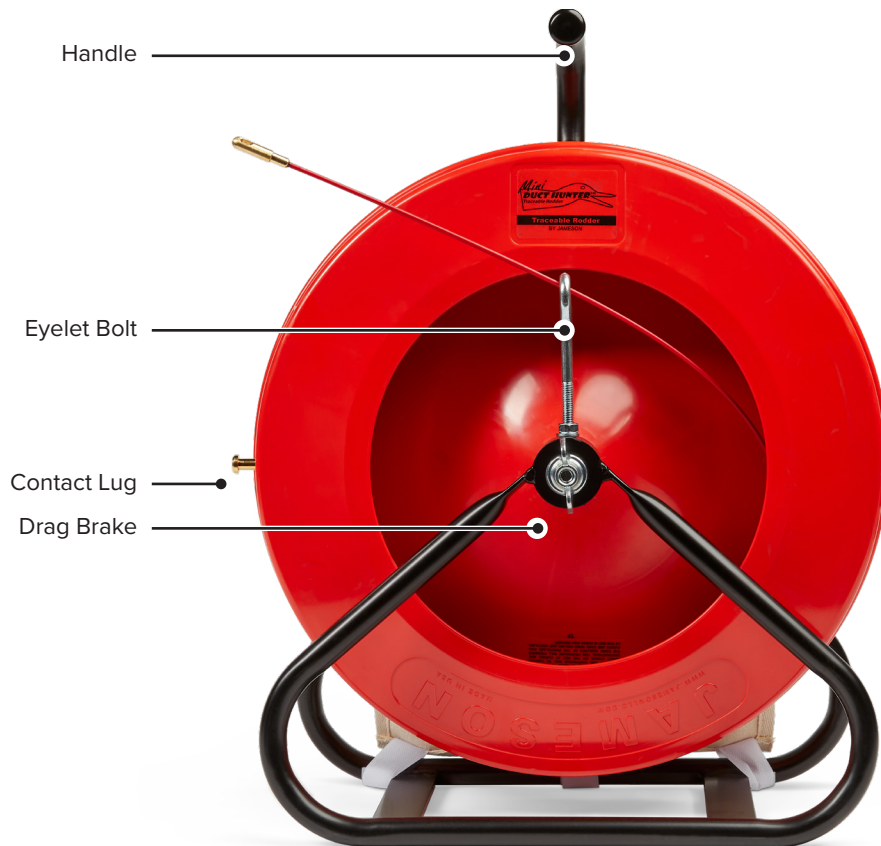

Splicing Rod or Attaching New End Ferrule

1. Cut away damaged section(s) of rod with a fine-tooth hacksaw, cable cutter or sharp knife. With pipe cutter and/or sharp knife, strip red protective jacket back from fiberglass core (see table below).

Do not cut fiberglass core when stripping jacket. Do not crush fiberglass core.

2. Once jacket is removed, use pipe cutter again to score a mark around fiberglass core approximately 1" from edge of jacket. Use sharp knife to carefully strip away 1" of fiberglass core closest to rod end to expose copper wire. Be careful not to damage wire. The 1" portion of rod closest to jacket will remain intact (Fig.1).

Rod Diameter	Strip Jacket	Core Exposed	Wire Exposed
1/8" Mini Duct Hunter	1.5"	.75"	.75"
3/16" Mini Duct Hunter	1.25"	.625"	.625"

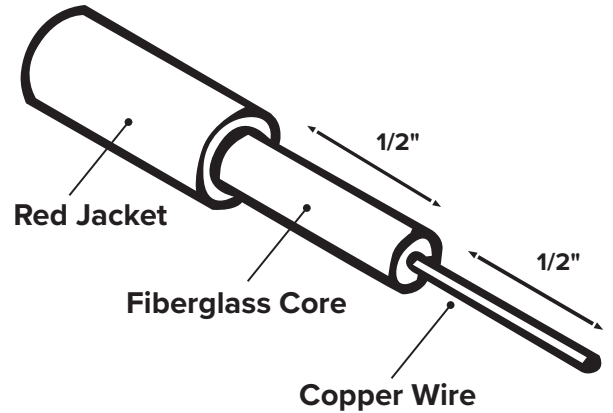

Fig. 1

3. Using sharp knife, strip away flat spot on remaining exposed fiberglass core approximately as deep as wire diameter. Cut exposed wire length according to above chart and lightly strip away thin coating on copper wire. Fold wire back along flat spot in fiberglass core (Fig. 2).
4. Attempt a test fit of replacement ferrule over exposed fiberglass core with wire folded back. It should be firm and snug with little or no play to assure wire contacts inside of ferrule. If too loose, cut away rod end and repeat steps 1-4.
5. Once proper fit is established, install end ferrule without adhesive and check for continuity of the internal copper wire using a digital multimeter. Touch a probe to end ferrule at each end of coiled rod. Any resistance reading (generally between 2-12 ohms) indicates proper continuity.
6. Remove end ferrule. Clean rod end and ferrule with cleaning solvent or alcohol to remove debris and glass fibers. Allow solvent to completely evaporate. Step 6 is extremely important.
7. Mix and apply adhesive to entire surface of fiberglass core and wire. Insert rod into ferrule as far as possible, enclosing end of red jacket in counterbore of ferrule. Wipe away excess adhesive.
8. Check rod again for continuity using digital multimeter. The adhesive will not set for 20 minutes. If no continuity, remove ferrule, clean off adhesive and repeat steps 1-7.

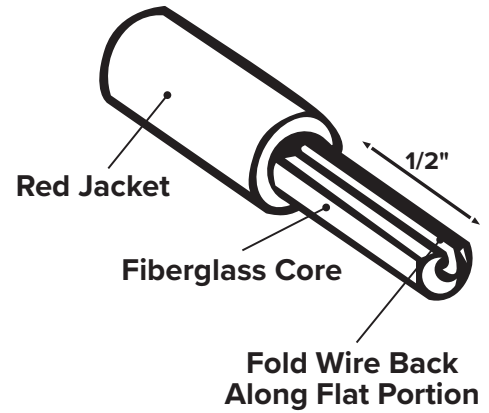

Fig. 2



End Ferrule Repair



Splice Repair

Splicing: Follow steps 1-8 for both ends of rod being spliced. Use splice ferrule instead of end ferrule. Before inserting prepared rod ends into splice ferrule, slide piece of heat shrink tubing over one rod end and move it along rod out of way.

Once a proper splice is obtained, wait at least 20 minutes for adhesive to set. Move heat shrink tubing over splice ferrule so it is completely covered. Use heat gun or blow torch to carefully shrink tubing, starting in center and working toward each end. Wipe away any adhesive that oozes from the heat shrink tubing.

Repaired or spliced rod should be allowed to cure 24 hours prior to use.