

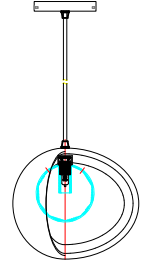

At Home In Any Environment

## Assembly & Installation Instructions for: 302350GL Pendant

Customer Service :(702)361-4345,(800)525-2655,customer.service@kalco.com



### WARNING - TO REDUCE THE RISK OF FIRE OR INJURY:

- 1.If you are unfamiliar with electrical wiring, call a qualified electrician to install this unit .More than one person may be necessary to install fixture ,make sure you have enough qualified help.
- 2.Turn off the power to the fixture's circuit at the service panel. Use a voltage detector to verify that the power is off.
- 3.DO NOT install bulb which exceeds the maximum wattage specified on the socket label.

### Fixture Assembly

Step 1. Attach mounting block to outlet box using 2 8-32 machine screws

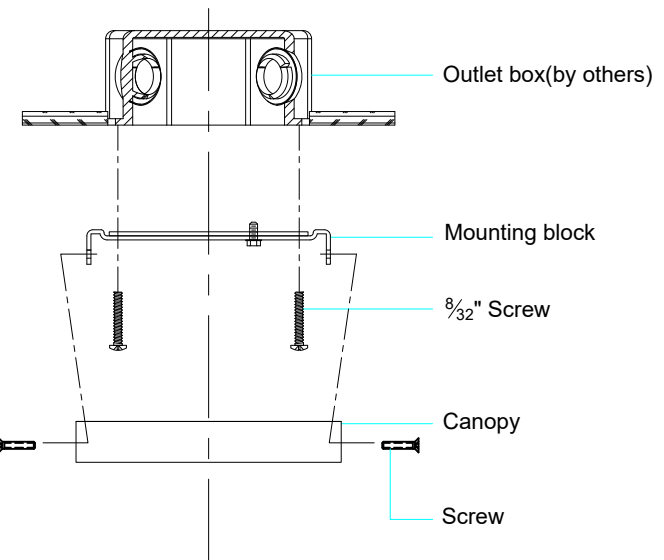

Step 2. Install G9 bulb,do not use bulbs that exceeds 40W.

Step 3. Screw the glass ball to lamp holder.

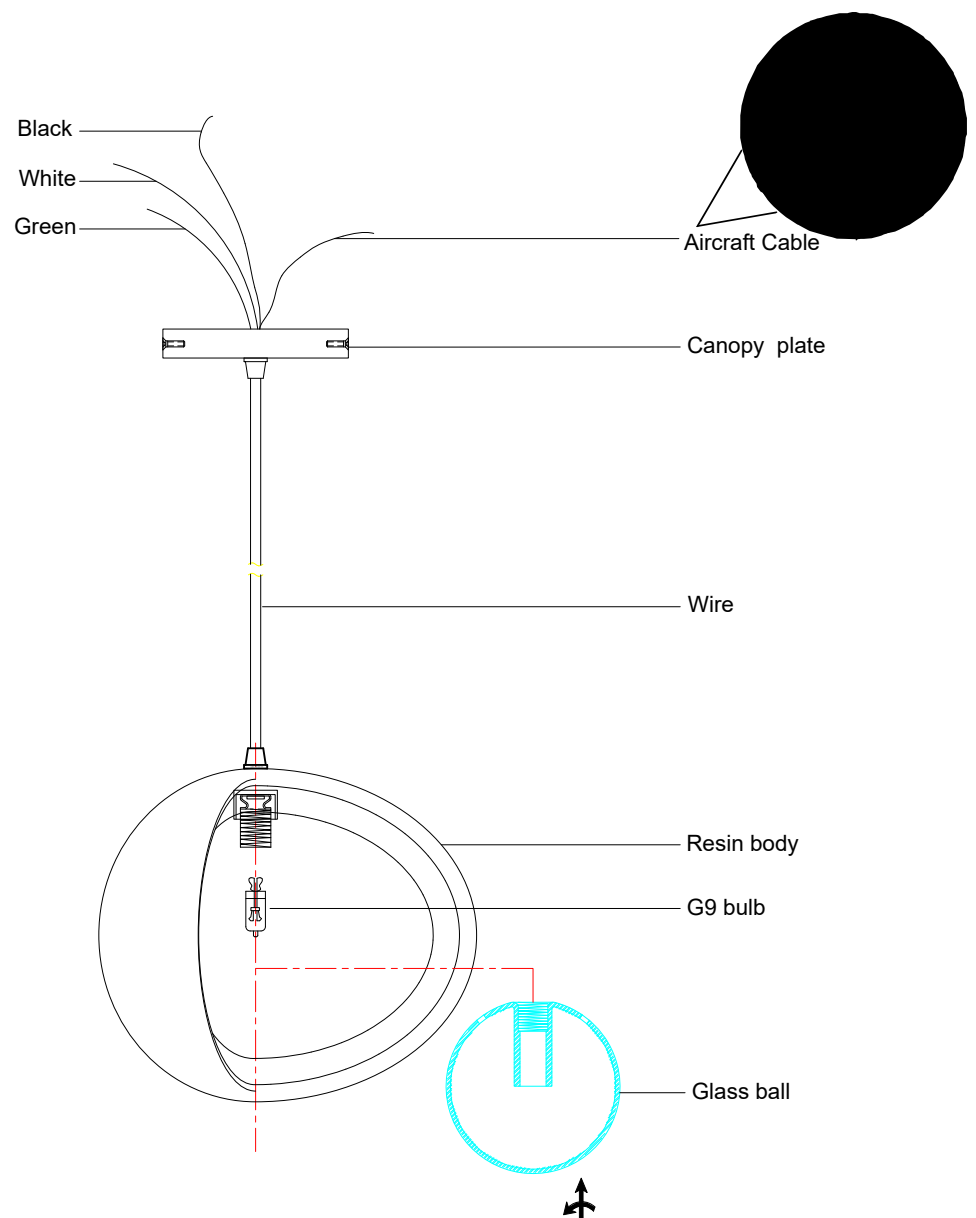



At Home In Any Environment

## Assembly & Installation Instructions for: 302350GL Pendant

Customer Service : (702)361-4345, (800)525-2655, customer.service@kalco.com

### Fixture Assembly

Step 4. Cut desired length of wires and prepare for connection; Identify fixtures wires as follows:

Black = L (Live)  
White = N (Neutral)  
Green = E (Ground)  
Bare silver = Aircraft cable (for weight support)

Step 5. Connect fixture white wire with power supply white wire, connect fixture black wire with power supply black wire, connect fixture green wire with ground wire in outlet box.

Step 6. Use wire nuts and black electrician tape to secure connections or as required as your local electric code

Step 7. Cut aircraft cable at desired length and secure it with cable lock and allen key as shown in image A1 for extra support.

Step 8. Carefully tuck all wires inside outlet box and secure canopy from the sides with the screws provided

Review connections and turn switch ON.  
Enjoy your new KALCO fixture!

