

# EB40 BATCH CONTROLLER



SIMPLE OPERATION,  
ADVANCED FEATURES

## BATCH CONTROLLER SINGLE-STAGE



The EB40 single-stage batch controller combines simple installation and operation with powerful advanced features contained in a rugged durable housing, making it the perfect solution for a wide range of batching applications.

Take control with our intuitive 4-button interface. Easily program your desired batch volume and let the controller do the rest. The bright, backlit 6-digit display provides clear visibility, even in challenging environments.

With a weather-resistant IP65 or IP66/67 and NEMA4X enclosure, you can trust the EB40 Batch controller to perform reliably, indoors or out. Upgrade your batching process today and experience the difference!

### FEATURES & BENEFITS

- Store up to 10 frequently used recipes for quick and easy recall with a **batch memory table**
- **Non-linear correction** for accurate measurements across a wide flow range
- Prevent costly overruns with built-in limits and **overrun correction**
- Enhance safety with an optional **interlock** that prevents operation without a receiving vessel
- **Built-in diagnostics** simplify installation and troubleshooting
- Maintain control with automatic **no signal detection** ensuring flow meter or input wiring failure does not result in uncontrolled batching

## COMMON APPLICATIONS

### Food and Beverage Industry:

- **Sauce Manufacturing:** Ensure consistent flavor and texture in sauces, dressings, and condiments by accurately controlling the addition of liquids.
- **Microbreweries:** Add exact strike water volumes every time for consistent batches.

### Cosmetic and Chemical Industries:

- **Chemical Mixing:** Accurately measure, blend and dilute chemicals for the production of cleaning agents, fertilizers, and other chemical products.
- **Cosmetic Production:** Control the precise addition of liquids in the manufacturing of lotions, creams, and perfumes.

### Industrial Applications:

- **Water Treatment:** Control the additions of chemicals for water purification and treatment processes.

### Other Applications:

- **Agriculture:** Control the dosage and application of liquid herbicides and pesticides in agricultural settings.
- **Aquaculture:** Accurately dispense medications and nutrients in fish farms and aquaculture facilities.
- **Wastewater Treatment:** Control the addition of chemicals in wastewater treatment processes including PAC dilution, reducing waste and increasing effectivity.
- **Building Industry:** Dilution and addition of cement additives, and dedusting agents.



## SUITABLE FLOW METERS

Pair the EB40 with the FLOMEC® flow meter for precise and efficient control of your process resulting in consistent product every time.



### OM SERIES OVAL GEAR

Ideal for measuring small volumes and viscous fluids with high accuracy



### G2 SERIES TURBINE

Ideal for high flow rate batching



### TM SERIES TURBINE

Ideal for water batching

Sizes	Flow Rates	Operating Pressures
¼" - 1.5"	0.26 GPH - 66 GPM 1 L/hr - 250 L/min	5800 PSI (400 bar)

Sizes	Flow Rates	Operating Pressures
½" - 1.5"	1-100 GPM 3.8-380 L/min	1500 PSI (102 bar)

Sizes	Flow Rates	Operating Pressures
½" - 1.5"	1-100 GPM 3.8-380 L/min	225 PSI (15.3 bar)

Sizes >1.5 in. are also suitable, subject to correct system configuration. Refer to FAQ's for more information.

## PRODUCT MODELS

ITEM	DESCRIPTION
EB401DOFA	Field Mount Batch Controller
EB401DOFA-R	Field Mount Batch Controller w/ 5A Mechanical Relay
EB401DOMA	Meter Mount Batch Controller
EB401DOMA-R	Meter Mount Batch Controller w/ 5A Mechanical Relay
EB406DOFM	Field Mount Batch Controller
EB406DOFM-R	Field Mount Batch Controller w/ 5A Mechanical Relay
EB406DOMA	Meter Mount Batch Controller
EB406DOMA-R	Meter Mount Batch Controller w/ 5A Mechanical Relay

## DIMENSIONS

Dimension "A"	Dimension "B"	Dimension "C"
4.5 in. (11.43 cm)	2.6 in. (6.6 cm)	3.9 in. (9.9 cm)

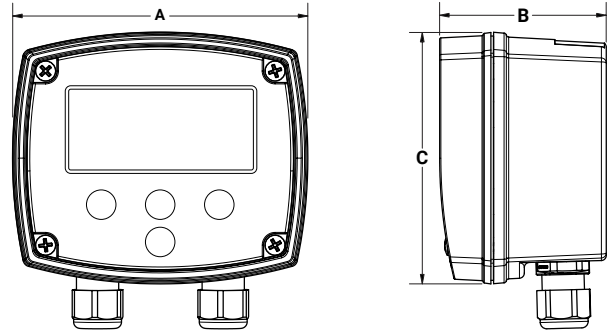

## SPECIFICATIONS

<b>Physical:</b>	Glass reinforced Nylon (PA6) with a Polycarbonate lens, Santoprene gasket, polyester decal. Enclosure provides an IP rating of IP66/67 for GRN housing and IP rating of 65 for Aluminum housing Optional powder coated Aluminum enclosure
<b>Operating Temperature:</b>	-22°F ~ +176°F (-30°C ~ +80°C)
<b>Electrical Entries:</b>	3 entries - M16 x 1.5 conduit thread
<b>LCD Display:</b>	Large dual line LCD with 6 characters x 17 mm high on top line 8 characters 7 mm high on bottom line. Backlight available with external DC power
<b>Units:</b>	Units are selectable for Litres, Cubic Metres, US Gallons, Imperial Gallons, Millilitres (Cubic Centimetres), Quarts, Fluid Ounces, Cubic Feet, Barrels, Kilograms, Pounds, or Custom Units of mass are configured by setting a units/litre conversion value in the configuration menu
<b>Flow meter Input Signals:</b>	Pulse/frequency input compatible with pulse signals from most flow meters
<b>Compatible Flow Meter Sensors:</b>	Reed Switch – 120Hz maximum NPN (hall effect sensor) – 2kHz maximum Variable Reluctance Coils (Turbine Flow meters) – 2kHz maximum Weigand Sensors (voltage pulse signals) – 2kHz maximum Minimum signal amplitude for Coil signals is 15mV pk-pk
<b>Sensor Power:</b>	12V regulated sensor supply is available with external DC power applied
<b>Safety Interlock Input:</b>	Normally open (NO) dry contact, switch, or reed switch input
<b>External Switch Inputs:</b>	Momentary normally open (NO) switch input Four inputs for remote access to all operator keys
<b>Battery Power:</b>	AA (14505) 3.6V Lithium Thionyl Chloride Battery Expected battery life is 10 years as a back-up battery
<b>External DC Power:</b>	Regulated 12V ~ 30V DC Typical current draw on external power is 100mA across this voltage range
<b>Digital Output:</b>	NPN (open collector, sinking) output, 30V dc / 1A maximum
<b>Relay Output (Optional):</b>	Optional mechanical relay for high current DC loads: 30V dc / 5A maximum External equipment is required for AC loads (wiring diagram 4.4.4)
<b>Standards:</b>	<b>FCC 47CFR 15:2024</b> Telecommunication, Radio Frequency Devices <b>ICES-003: 2020</b> Issue 7, Information Technology Equipment (Including Digital Apparatus) - Limits and Methods of Measurement <b>ENIEC 61326-1:2021</b> Electrical equipment for measurement, control and laboratory use - EMC requirements - Part 1: General requirements

## ACCESSORIES & SPARES

Description:	Includes:	Part No:
Front Housing Kit (Nylon)	Front housing (glass reinforced nylon), screen cover, FLOMEC decal, screws, and gasket	1502072
Front Housing Kit (Aluminum)	Front housing (Al), screen cover, FLOMEC decal, screws, and gasket	1502073
Flow Meter Mount Rear Housing Kit (GRN)	Rear housing for flow meter mounted instrument (glass reinforced nylon); Includes the required fasteners and seals for flow meter mounting	1502069
Flow Meter Mount Rear Housing Kit (Aluminum)	Rear housing for flow meter mounted instrument (Al); Includes the required fasteners and seals for flow meter mounting	1502034
Field Mount Rear Housing Kit (GRN)	Rear housing for field mounted instrument (glass reinforced nylon)	1502068
Field Mount Rear Housing Kit (Aluminum)	Rear housing for field mounted instrument (Al)	1502035
Screen Protector Kit	Polycarbonate screen cover, and screws	1506018
Cable Kit (Suits RT40/EB40)	1m, USB-A to USB-Micro Bm Cable	1519015
Housing Gasket	Enclosure seal (suits both nylon and aluminium enclosures)	1304024
Flow Meter Mount Seal	BS039 Buna-N (Nitrile) O-Ring	BS039B
Decal (facia)	Self-adhesive decal (facia) with FLOMEC® logo	1315189
Replacement Battery	3.6V AA Lithium Thionyl Chloride Battery	1312125
<i>Alternative Replacement Battery for Safe Area Unit Only</i>		Tekcell SB-AA11 Tadiran TL5903/S
Wall Mount Kit	2x wall mount brackets, 4 mounting screws	1522001
Pipe Mount Kit	Wall mount kit plus pipe clamps	1522002

## APPROVALS / WARRANTY



NEMA  
4

IP66/67



**FLOMEC** CDS Configure/Diagnostics Software

**DOWNLOAD** Visit [FLOMEC-CDS.com](http://FLOMEC-CDS.com) for more information.



**EB40**  
**Batch Controller**

Recommended for a wide range of single stage, safe area applications with an economical price where accuracy and features are important.



**EB11**  
**Batch Controller**

Recommended for most applications using single-stage or dual-stage control of any non-flammable liquids, and in environments where no flammable vapors or gases are present



**F130**  
**Intrinsically Safe**  
**Batch Controller**

Recommended for all application using single-stage or dual-stage control with flammable liquids, or environments where flammable vapors or gases are present

	EB40	EB11	F130
<b>Control Option</b>			
Single-Stage	✓	✓	✓
Dual-Stage		✓	✓
<b>Features</b>			
Frequently Used Recipe	✓		
Non-linear Correction	✓		
Self-learning Overrun Correction	✓		✓
Manual Overrun Correction		✓	
Batch Interlock	✓		
Built In Diagnostics	✓		
FLOMEC CDS Compatible	✓		
Automatic No Signal Detection	✓		✓
Count Up / Count Down Function	✓	✓	✓
LED Backlight	✓	✓	✓
Auto Backup of Settings	✓	✓	✓
<b>Enclosure</b>			
Aluminum	✓		✓
GRN/P (Glass Reinforced Nylon/Plastic)	✓	✓	✓
Stainless Steel			✓
<b>Input Types</b>			
Standard Flow Meter Inputs (Reed, NPN, Coil, Weigand)	✓	✓	✓
Namur	✓	✓	✓
<b>Control Outputs</b>			
Optional Internal Mechanical Relay	✓		✓
NPN 1A (max)	✓		
NPN 300mA (max)		✓	✓
<b>Approvals</b>			
Hazardous Area (ATEX/IECEX)			✓
IP65	✓		
IP66/67		✓	✓
NEMA4X	✓	✓	✓

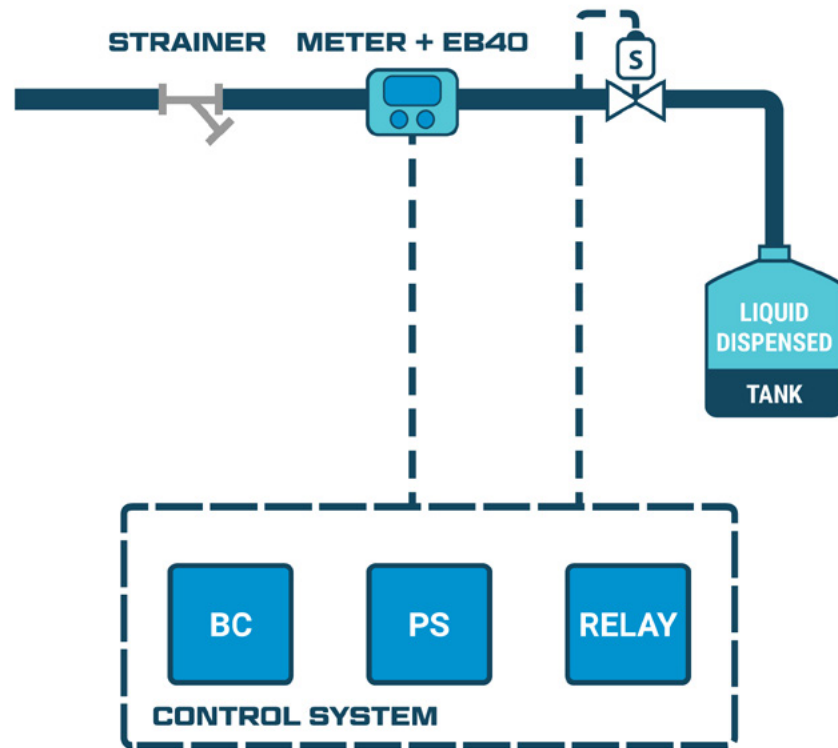

## SINGLE-STAGE (SINGLE VALVE) SYSTEM

Single-stage systems utilize a single valve for on/off control of the liquid. Single-stage systems are the simplest way to implement a batch controller into your process, however they do have limitations.

In cases with high flow-rates a single stage system can be less accurate than a dual stage (two valve) system, although by far the biggest down-side of single-stage systems is pressure spikes – commonly referred to as water hammer. Pressure spikes can occur when the liquid has a high amount of momentum; from a large pipe size, high flowrates, or both. In these systems a quickly closing valve causes the liquid to stop suddenly, creating a rapid spike in pressure and potentially damaging valves, fittings, or pumps.

A single-stage system is the recommended solution for 1 in. (25 mm) lines and smaller, with pressures below 150 psi (10 Bar). Larger gravity fed systems (no pump), or large pipes with very low flowrates can also work effectively as a single stage system.

As a last resort, pressure spikes can be eliminated using a water-hammer arrestor or pressure accumulator.

### ***Transistor or Mechanical Relay?***

Whenever possible, select the transistor output if the solenoid valve operates at less than 1 Amp. For higher current requirements –such as when using larger valves, bigger pipe sizes, or thicker fluids—choose the mechanical relay option instead.

When controlling higher-power equipment like pumps exceeding 5 Amps, use the transistor output in combination with an external mechanical relay. In general, a solid-state transistor offers greater reliability and a lower likelihood of failure compared to a mechanical relay.

**TERMINAL CONNECTIONS**

The terminal connections are divided into 4 separate sections by their function, see image below. There is a separate ground (GND) terminal in each section of terminals; as this instrument has a common ground, all GND terminals are internally connected.

**Standard Model**

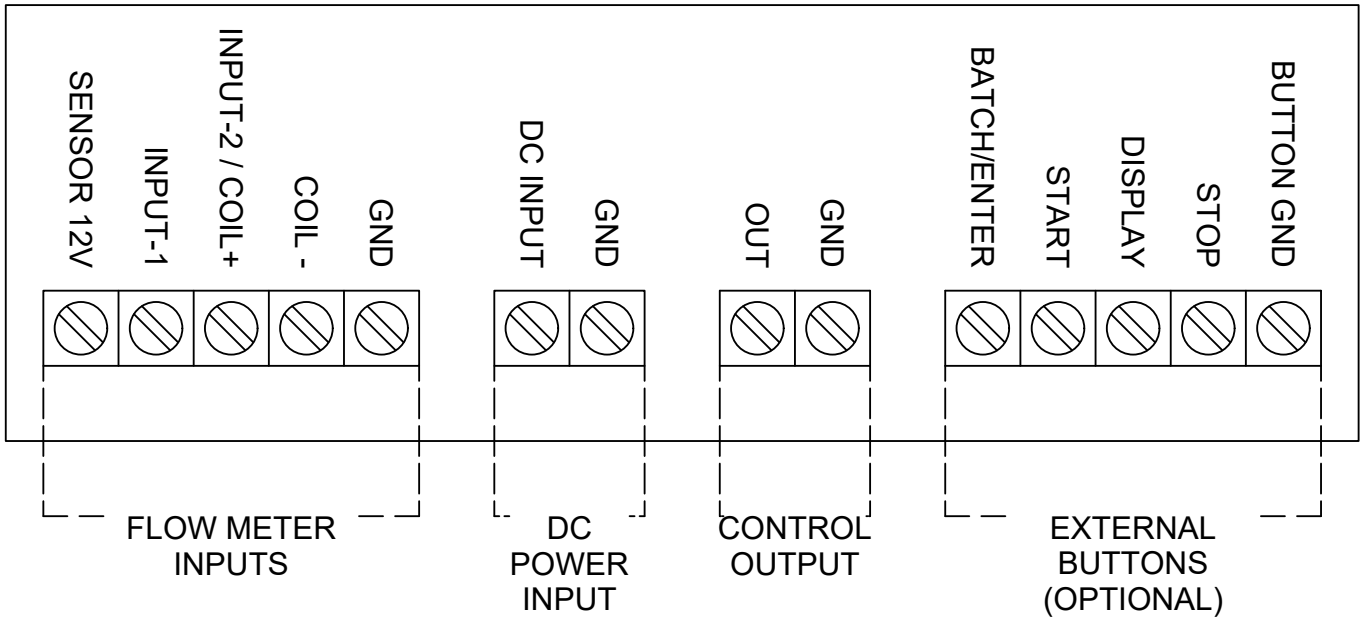

**Relay Model**

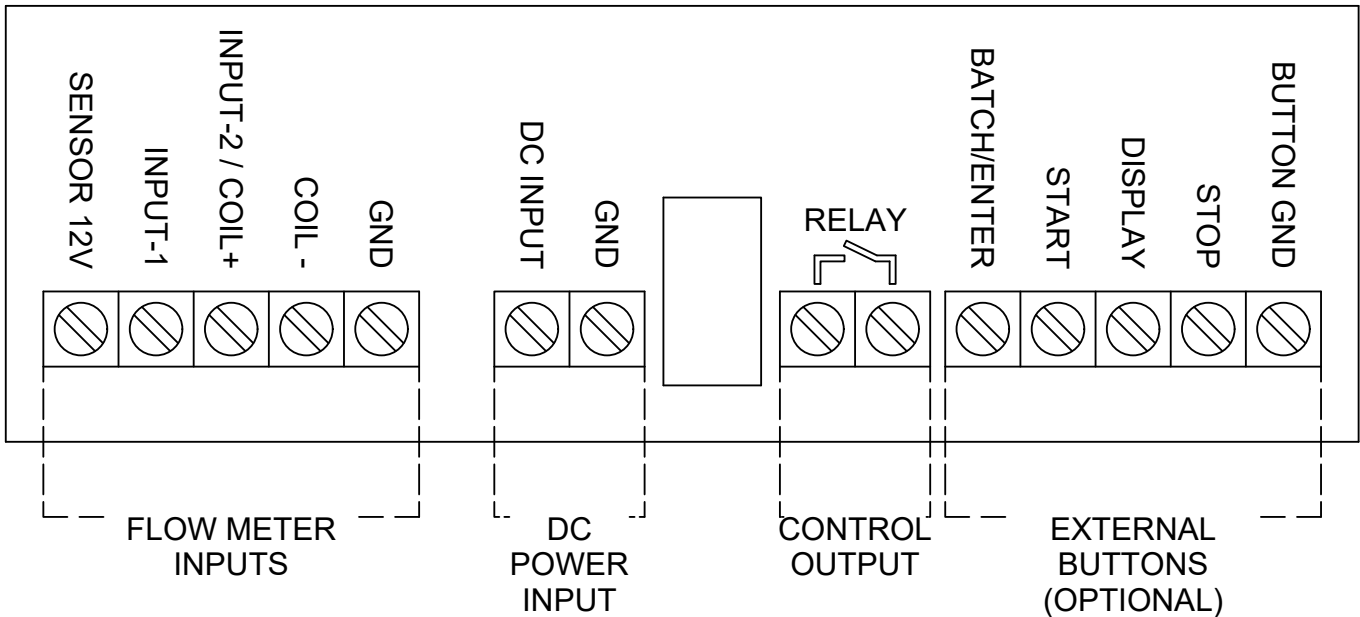

## CONNECTING A FLOW METER

The input type must be set in the software before the below wiring connections will function.

### 4.3.1 - NPN Sensor Input (Hall Effect) - OM Series and DP Series Flow Meters

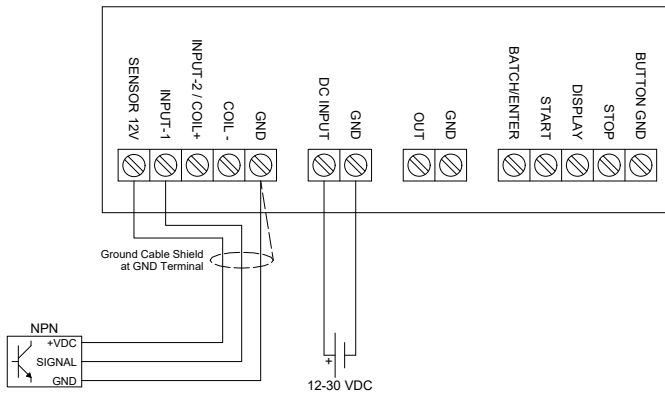

### 4.3.2 - Reed Switch Input

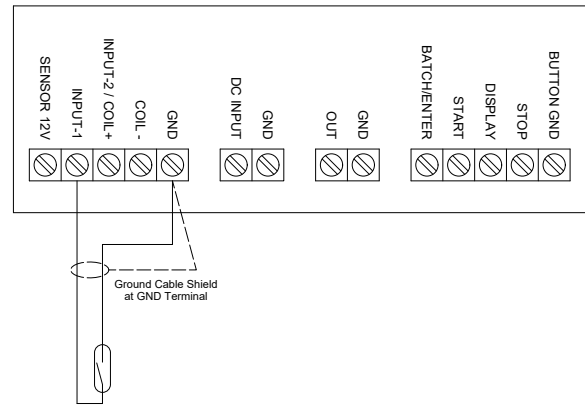

### 4.3.3 - Variable Reluctance Coil Input - Turbine Flow Meters

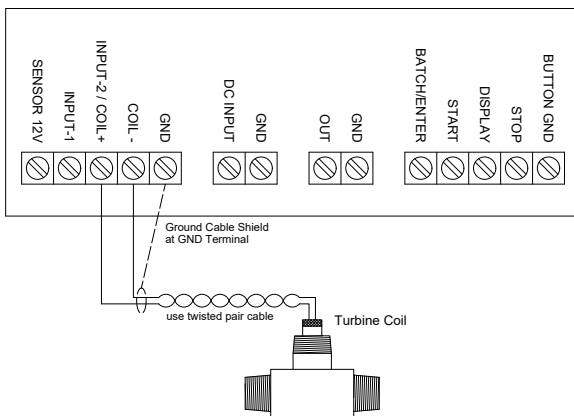

### 4.3.4 - QS100 / QS200 - 2 Wire Pulse

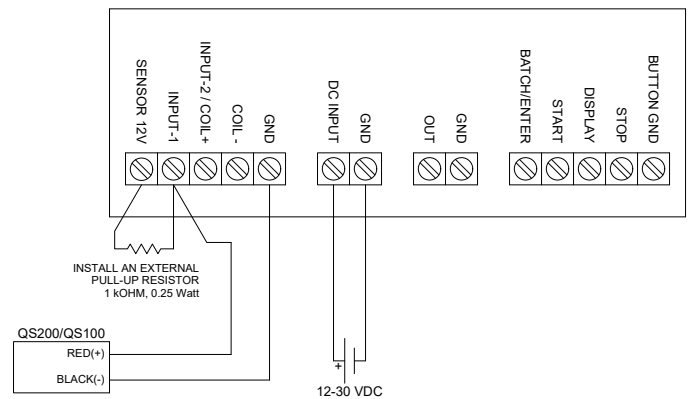

## VALVE COMPATIBILITY

With multiple output options and high current ratings, the FLOMEC® EB40 Batch Controller is compatible with a wide range of solenoid valves. Direct acting solenoid valves or indirect acting solenoid valves (also known as pilot-assisted solenoid valves) are the most common choices, and with up to 1 Amp of electrical switching available from the standard EB40, or up to 5A from the optional electromechanical relay, there will be many solenoid valves available that are compatible with the EB40.

For installations where compressed air is available it is also possible to use the EB40 with a pneumatic pilot valve and pneumatically actuated valves, this can be particularly economical for installations with large diameter pipes. When working with applications using large diameter pipes and high flow rates, using a pneumatic valve design with the addition of a speed controller can also be an effective way to avoid pressure spikes or water hammer. With the EB40's automatic overrun correction feature, the EB40 will compensate for the slow closing valve, achieving an accurate batch volume every time.

For simple liquid applications such as water, the most common choice for a solenoid valve should be an indirect acting brass valve with NBR or EPDM seat/seals, and a 24V coil. For example; part number 8240400.9101.02400 from IMI Buschjost.

When making the final choice of a valve it is recommended that any applications dealing with aggressive chemicals, high viscosities, or high liquid pressures, it is recommended that the user seeks guidance from a valve manufacturer/distributor to ensure the performance of the valve meets customer expectations for flow, pressure, and longevity.

<i>Valve or Pump Voltage</i>	<i>Maximum Power Rating</i>	<i>Controller Required</i>	<i>Wiring Diagram</i>
12Vdc	12 Watt	Standard Model	4.4.1
12Vdc	60 Watt	Relay Model	4.4.2
24Vdc	24 Watt	Standard Model	4.4.1
24Vdc	120 Watt	Relay Model	4.4.2
30Vdc	30 Watt	Standard Model	4.4.1
30Vdc	150 Watt	Relay Model	4.4.2
3-wire valve	N/A	Relay Model	4.4.3
Higher Power DC Device	Refer ratings of external relay	Standard Model with additional external relay	4.4.4
115Vac / 230Vac			

**WIRING DIAGRAMS - CONNECTING A SOLENOID VALVE**

**4.4.1 - DC Solenoid Valves up to 1A**  
*Standard Model*

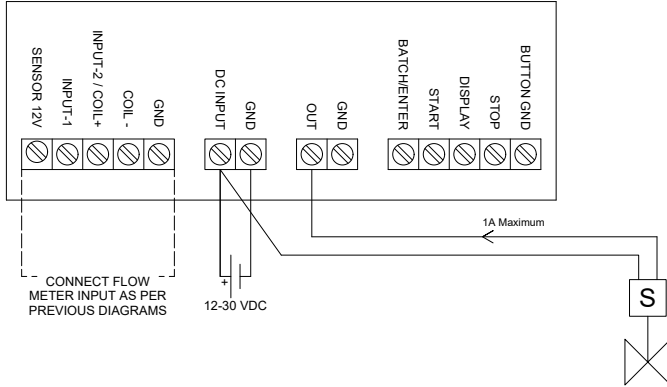

**4.4.2 - DC Solenoid Valves up to 5A**  
*Relay Model*

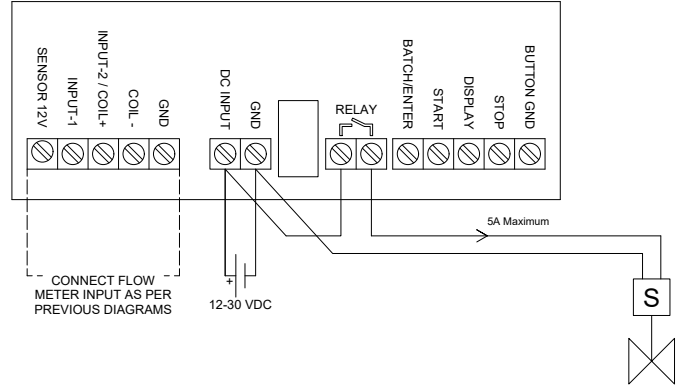

**4.4.3 - 3-wire Solenoid Valves**  
*Relay Model*

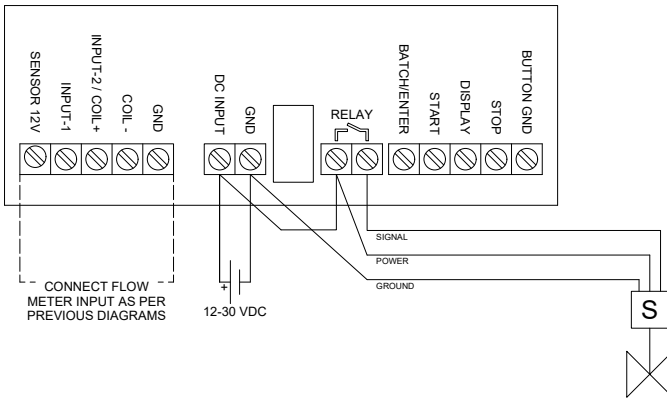

**4.4.4 - External Relay for High Current DC or 115Vac / 230Vacq**  
*Standard Model with additional external relay*

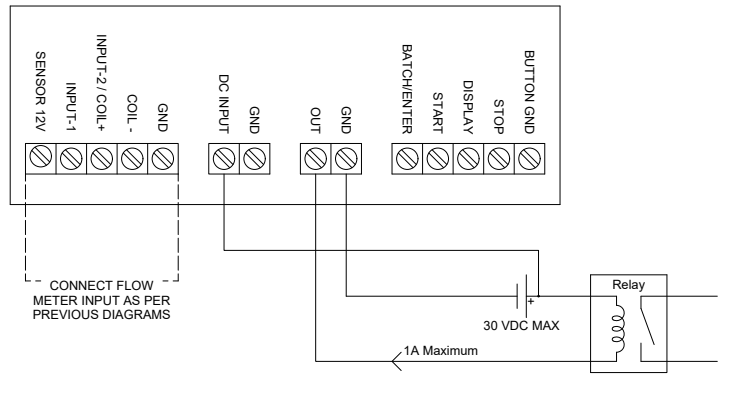

## EB40 FEATURES

### Batch Interlock

The EB40 can be installed using the optional Batch Interlock feature which allows the use of a limit switch or a proximity sensor to detect the presence of an un-safe condition, or to prevent starting the batch controller when a receiving vessel is not present at the dispensing point.

The Batch Interlock should be connected to a proximity sensor with a normally open (NO) dry-contact output, or a reed switch, and can be wired as below.

Please note that the Batch Interlock input cannot be used with a Coil Input from a turbine flow meter, due to shared input circuitry and connection terminals. For any installations using a turbine flow meter which need to use the batch interlock function, the turbine flow meter should be equipped with an amplified output (3-wire output).

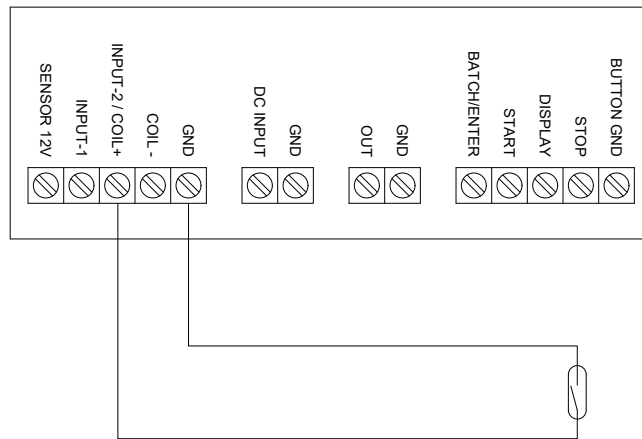

### Remote Switches

External switches may be connected to the EB40 display to allow remote access to button functions, or to allow use of heavy industrial push buttons in environments where the standard switches may break or wear. Momentary normally open (NO) switches **MUST** always be used.

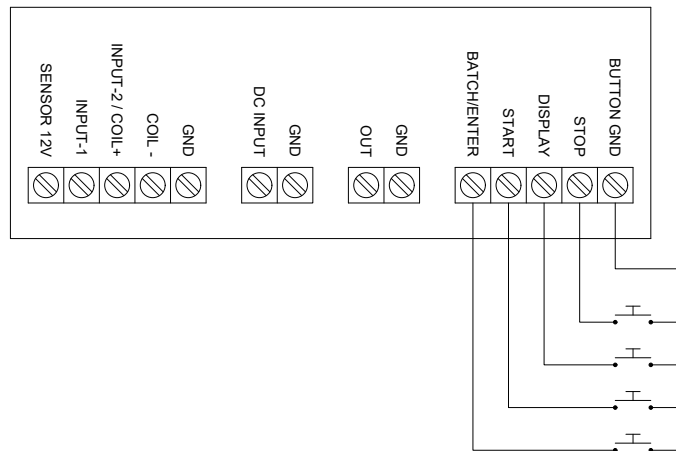

## EB40 BATCH CONTROLLER

### Q Do I need single or dual-stage batch control?

**A** The EB40 is suitable for single stage operation. For dual stage operation use the EB11 or F130. Single stage operation is suitable for line sizes up to 40 mm or for larger slower acting valves. Hydraulic shock or water hammer may cause flow meter damage if a larger valve closes too fast.

### Q Do I need power to the batch controller?

**A** 10-30 Volts dc power will be required as the EB40 has either a solid state or mechanical relay to control a valve.

### Q How do I choose that right solenoid for my system?

**A** The choice of solenoid depends on a variety of specifications. The voltage, the pipe size, the pressure in the line, the chemical compatibility, the close rate and whether the valve is normally open or normally closed. The power rating is important to determine whether a mechanical relay is required between the EB40 and the solenoid, the maximum rating for a solenoid that can be wired directly to the output of the EB40 is 1 amp. For the mechanical relay it is 5 amps. Multiply the voltage by the current rating to calculate the maximum power rating of the solenoid that can be used. Power (W) = Voltage (V) x Current (A)

### Q Can I pause the batch?

**A** The batch volume can be paused and restarted at any time with the touch of a button.

### Q Can I set multiple batch totals?

**A** The EB40 has a ten batch volume storage, that can be easily selected. The volumes can be programmed with the CDS software from any Windows computer.

### Q Can I use the EB40 to start and stop a pump?

**A** The EB40 can be used to turn on and off a pump using the mechanical relay installed inside. The more accepted and accurate method is to use an automatic valve to shut off flow. This method has a faster response and gives more repeatable batch volumes.

### Q Can the EB40 be used in areas containing flammable liquids such as unleaded fuel or alcohol?

**A** No. The EB40 Batch Controller can only be used in areas where there is no risk of igniting an explosive gas or dust atmosphere e.g. petrol, solvents, alcohols. Consider the F130 Intrinsically Safe Batch Controller for such applications.

### Q Can I use the EB40 with remote start/stop/reset buttons?

**A** Yes, the EB40 Batch Controller has remote relays so that an operator can start and stop a batch and rest it if required. It also has an interlock that will prevent the EB40 from measuring until a vessel is in place when used with a proximity sensor.