

# ADVANCED INVERTER/CHARGER

## User Manual

AIC-2000-12-SL

AIC-3000-12-SL

AIC-3000-12-DL

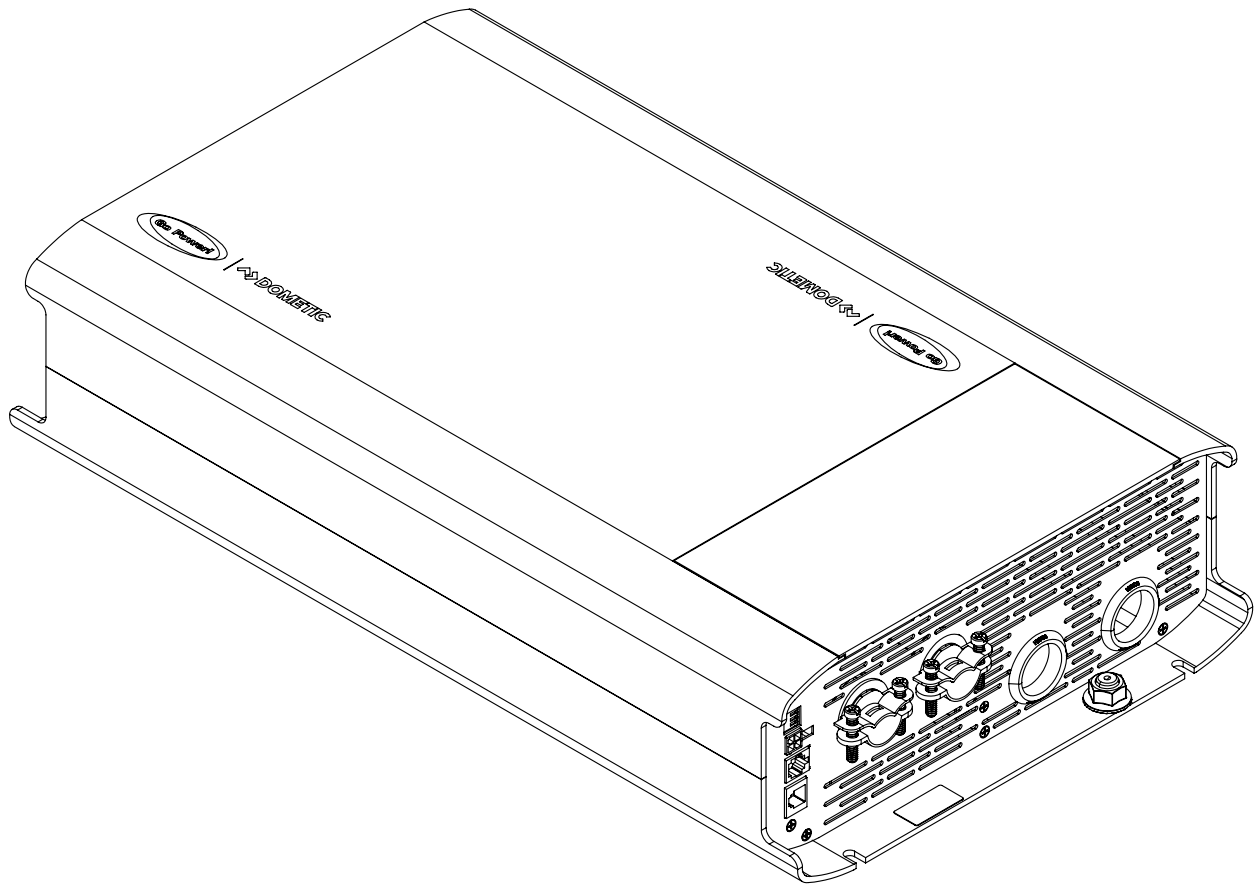

Congratulations on purchasing your Go Power! | Dometic Advanced Inverter/Charger. This manual will assist you with the installation process. Please read and understand the manual before beginning installation, and retain it for future reference.

---

Record the unit model and serial number below. It is much easier and quicker to record this information now at the pre-installation stage.

Model number:

Serial number:

Date of install:

Battery bank information: (size, install date, battery type)

1. GENERAL INFORMATION .....	4
1.1 CAUTIONS/WARNINGS .....	4
1.2 DISCLAIMERS .....	7
1.3 INCLUDED PARTS .....	7
1.4 FEATURES.....	8
1.5 DIMENSIONS .....	10
1.6 ACCESSORIES .....	11
2. INSTALLATION .....	11
2.1 REQUIRED TOOLS AND MATERIALS .....	11
2.2 LOCATION AND ENVIRONMENTAL REQUIREMENTS.....	11
2.3 MOUNTING THE INVERTER/CHARGER.....	12
2.4 GENERAL WIRING SPECIFICATIONS.....	13
2.5 DC WIRING .....	14
2.6 AC WIRING.....	18
2.7 RV-C COMMUNICATION.....	27
2.8 RV-C INSTANCE NUMBERS .....	30
2.9 FINAL INSPECTION .....	30
2.10 TESTING THE INSTALLATION .....	30
3. OPERATION.....	31
3.1 POWER ON/OFF.....	31
3.2 STATUS LED INDICATOR.....	31
3.3 POWERTRAK™ DISPLAY .....	32
3.4 BATTERY TYPE.....	33
3.5 BATTERY CHARGER SPECIFICATIONS .....	33
3.6 TEMPERATURE COMPENSATION .....	34
3.7 LOAD SENSE .....	34
3.8 AC PASS-THROUGH MODE .....	35
3.9 CHARGING MODE.....	36
3.10 INVERTING MODE .....	37
3.11 POWER SHARING MODE .....	38
3.12 STATUS PARAMETERS.....	40
3.13 CONFIGURABLE SETTINGS.....	41
3.14 FACTORY DEFAULT VALUES .....	43
3.15 TROUBLESHOOTING .....	44
3.16 MAINTENANCE .....	48
4. SPECIFICATIONS .....	49
5. WARRANTY RETURN PROCEDURE .....	51
6. END OF LIFE - RECYCLING INFORMATION .....	51





1.1 CAUTIONS/WARNINGS

This document contains important safety instructions for the Go Power! | Dometic Advanced Inverter/Charger. Read all instructions and cautionary markings on the product and on any accessories or additional equipment included in the installation. Failure to follow these instructions could result in severe shock or possible electrocution. Use extreme caution at all times to prevent accidents.





All electrical work must be performed in accordance with local and national electrical codes. These instructions are for use by qualified personnel who meet all local and governmental code requirements for licensing and training for the installation of electrical power systems with AC and DC voltage up to 600 volts.

Installation, maintenance, and connection of Inverter/Chargers must be performed by qualified personnel, in compliance with local electrical standards, wiring rules, and the requirements of local power authorities and/or companies.

Safety regulations relevant to the location shall be followed during installation, operation, and maintenance. Improper operation may have a risk of electric shock or damage to equipment and property.

	<b>WARNING!</b> Hazard to Human Life	This type of notation indicates that the hazard could be harmful to human life.
	<b>WARNING!</b> Shock Hazard	Danger of shock or electrocution.
	<b>WARNING!</b> Burn/Fire Hazard	Danger of hot surface and/or fire.
	<b>CAUTION!</b> Hazard to Equipment	This type of notation indicates that the hazard may cause damage to the equipment.
	<b>IMPORTANT</b>	This type of notation indicates that the information provided is important to the installation, operation, and/or maintenance of the equipment. Failure to follow the recommendations in such a notation could result in annulment of the equipment warranty.

**General Safety**

	<b>WARNING!</b> Limitations on Use	This equipment is NOT intended for use with life support equipment or other medical equipment or devices.
	<b>CAUTION!</b> Equipment Damage	This product is designed for indoor/compartment installation. It must not be exposed to any liquids or moisture of any type.
	<b>IMPORTANT</b>	Only use components or accessories recommended or sold by Go Power!   Dometic or its authorized agents.
	<b>IMPORTANT</b>	Do not attempt to install this equipment if it appears to be damaged in any way. See the warranty section for instructions on returning the equipment.

## Personal Safety



**WARNING!**  
Personal Injury

Use safe lifting techniques when lifting this equipment as recommended by the Occupational Safety and Health Association (OSHA) or other local codes.

Use standard safety equipment when working on this equipment, such as safety glasses, ear protection, steel-toed safety boots, safety hard hats, etc.

Use standard safety practices when working with electrical equipment (remove all jewelry, use insulated tools, wear cotton clothing, etc.).

Never work alone when installing or servicing this equipment. Have someone nearby that can assist if necessary.

Do not touch the Inverter/Charger during operation. The temperature of some parts of the device may exceed 60° during operation. Let it cool for at least 5 minutes after shutdown before touching it.

Ensure that children, pets, and other animals are kept away from the Inverter/Charger, solar arrays, battery bank, and utility grid components.

If the equipment is used in a manner not specified by the manufacturer, the protection provided by the equipment may be impaired.

## Equipment Safety



**WARNING!**  
Lethal Voltage

Review the system configuration to identify all possible sources of energy. Ensure ALL sources of power are disconnected before performing any installation or maintenance on this equipment. Confirm that the terminals are de-energized using a voltmeter rated to at least CT II 600V.

Do not perform any servicing other than that specified in the installation instructions unless qualified to do so, or have been instructed to do so by Go Power! | Dometic technical support personnel.

To avoid electric shock, disconnect the DC input and AC input of the Inverter/Charger at least 5 minutes before performing any installation or maintenance.

Do not tighten the AC and DC terminals or pull on the AC and DC wiring when the inverter is running.



**WARNING!**  
Fire Hazard

Do not keep combustible or flammable materials in the same room with the equipment. Some products contain relays with moving parts and are not intrinsically safe.

Ensure AC, DC, and ground cable sizes conform to local codes. See product manuals for minimum size requirements.

Ensure all conductors are in good condition.

Do not operate the unit with damaged or substandard cabling.



**CAUTION!**  
Equipment Damage

When connecting cables from the Inverter/Charger to the battery terminals, ensure proper polarity is observed. Incorrect connections may damage or destroy the equipment and void the warranty.

Thoroughly inspect the equipment prior to energizing. Verify that no tools or equipment have been inadvertently left behind.

Ensure clearance requirements are strictly enforced.

Keep all vents clear of obstructions that can prevent proper air flow around, or through, the unit.



**CAUTION!**  
Equipment Damage

Static electricity may damage electronic components. Take appropriate steps to prevent such damage to the Inverter/Charger; otherwise, the warranty may be void.

**Battery Safety**



**WARNING!**  
Explosion, Electrocution, or  
Fire Hazard

Ensure the cables (conductors) are properly sized.

Ensure clearance requirements around the batteries are strictly enforced.

Ensure the area around the batteries is well ventilated and clean of debris.

Never smoke, or allow a spark or flame, near the batteries.

Always use insulated tools. Avoid dropping tools onto batteries or other electrical parts.

Ensure battery is within specified operating temperature limits before charging.

Never use old or untested batteries. Check the label on each battery for age, type, and date code to ensure all batteries are identical.

If a battery must be removed, always remove the grounded terminal from the battery first. Make sure all devices are de-energized or disconnected to avoid causing a spark.

Use the battery types recommended by Go Power! | Dometic. Follow the battery manufacturer's recommendations for installation and maintenance.

Insulate batteries as required to ensure operating temperature specification is maintained. Discharged batteries are more susceptible to damage and degradation than charged batteries.

If a remote or automatic generator control system is used, disable the starting circuit and/or disconnect the generator from its starting battery while performing maintenance to prevent accidental starting.

Wear complete eye and clothing protection when working with batteries. Avoid touching bare skin or eyes while working near batteries.

Keep plenty of fresh water and soap nearby in case battery acid contacts skin, clothing, or eyes.

If battery acid contacts skin or clothing, wash immediately with soap and water. If acid enters the eye, immediately flood it with cold running water for at least 20 minutes and get medical attention as soon as possible.



**IMPORTANT**

## 1.2 DISCLAIMERS

**IMPORTANT:** Please follow the installation and wiring instructions exactly as outlined to ensure safety. We recommend installation by a certified RV technician or licensed electrician to ensure compliance with applicable electrical codes. While we have made every reasonable effort to ensure the accuracy of the instructions in this manual, Go Power! | Dometic does not guarantee the information is free of errors, nor do we make any representation, warranty, or guarantee that the content is accurate, complete, reliable, or up to date. The specifications provided are for reference only and are subject to change without notice

**DISCLAIMER:** Go Power! | Dometic disclaims liability for any direct, indirect, or incidental damages caused by, or in case of, installation not performed following the instructions and cautions in this manual. Go Power! | Dometic will refuse requests for exchanges or returns, resulting from the purchase and installation of items which do not comply with local codes. To avoid such concerns Go Power! | Dometic recommends installation by a professional electrician or RV technician. Examples that are shown within this manual are for illustrative purposes only.

## 1.3 INCLUDED PARTS

**Note** Please unpack and make sure all parts shown in the list below are included in the kit. If any parts are missing please contact the customer service team at 1.866.247.6527.

### 1.3.1 PARTS CHECKLIST

ITEM	QUANTITY		
	AIC-2000-12-SL	AIC-3000-12-SL	AIC-3000-12-DL
Advanced Inverter/Charger	1		
Battery Temperature Sensor	1		
Pre-installed DC Terminal Flange Nut: M10	2		
Pre-installed Ground Terminal Nut: M10	1		
DC Terminal Lugs: M10 (3/8")	2		
Network Cable	N/A	1	
Power Disconnect Harness (84283)	1		

1.4 FEATURES

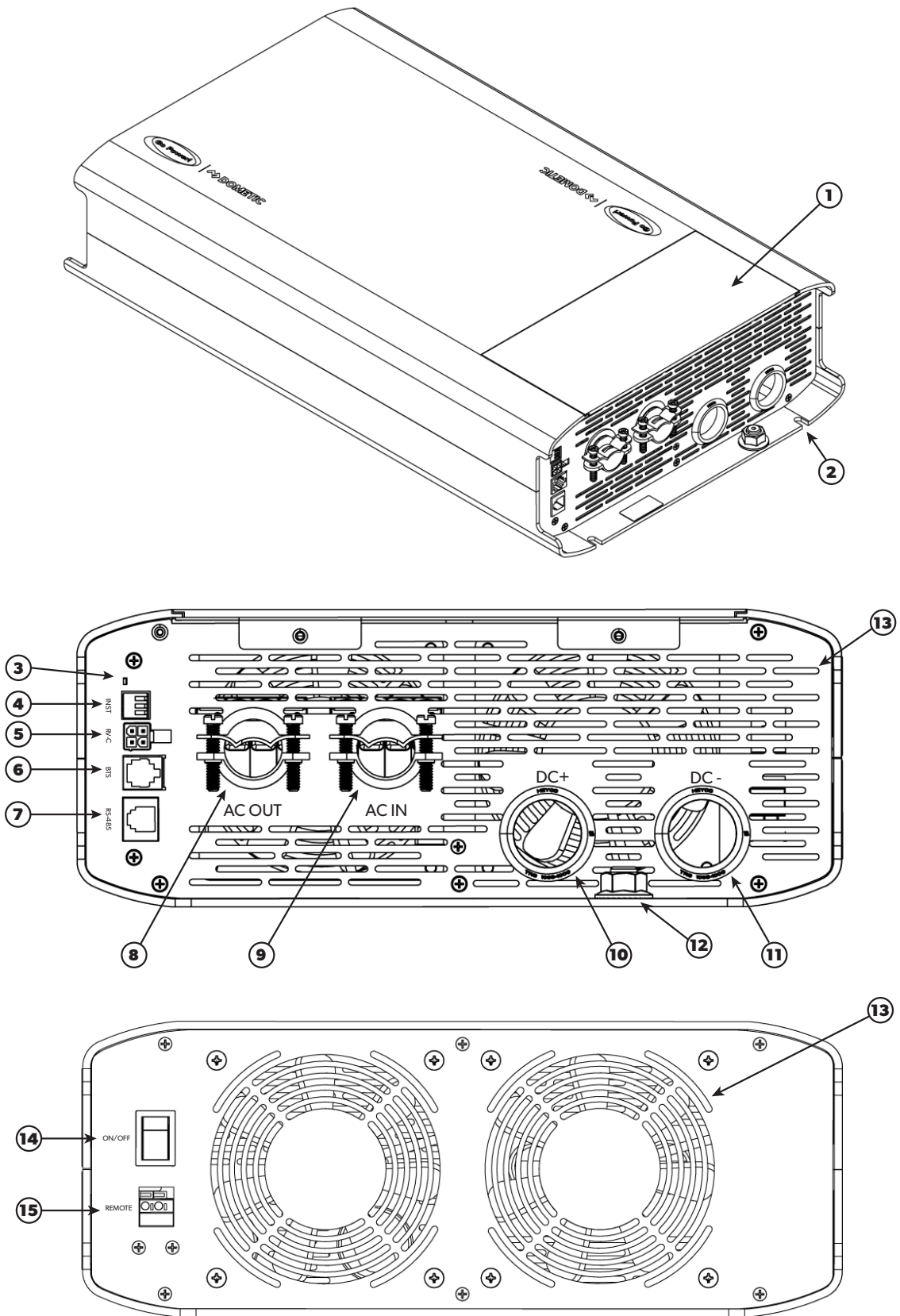

NO.	FEATURE	DESCRIPTION
1	Terminal Access Cover	Remove this sliding cover to access the AC and DC terminals.
2	Mounting Slots (x4)	Use these slots to secure the Inverter/Charger to the mounting surface.
3	Status LED	This LED indicates the status of the Inverter/Charger. Refer to section 3.2 for more details.
4	RV-C Instance DIP Switches	Use the DIP switches to set the RV-C instance number of the Inverter/Charger. Refer to section 2.8 for more details.
5	RV-C Port	Use this port to connect the Inverter/Charger to the RV-C system. Refer to section 2.7 for pinout details.
6	Battery Temperature Sensor (BTS) Port	Use this port to connect the battery temperature sensor to the Inverter/Charger.
7	RS-485 Port	This port is reserved.
8	AC Output Terminal Access	Strain relief clamps provided to secure AC output wires up to 0.6" in diameter for the AIC-2000-SL-12/AIC-3000-SL-12, and 1.0" for the AIC-3000-DL-12.
9	AC Input Terminal Access	Strain relief clamps provided to secure AC input wires up to 0.6" in diameter for the AIC-2000-SL-12/AIC-3000-SL-12, and 1.0" for the AIC-3000-DL-12.
10	Positive (+) DC Terminal	Insert the battery bank positive (+) cable into the Inverter/Charger through this grommet.
11	Negative (-) DC Terminal	Insert the battery bank negative (-) cable into the Inverter/Charger through this grommet.
12	DC Ground Terminal	Use this connection to ground the exposed chassis of the Inverter/Charger to the DC grounding system.
13	Air Vents	Air is drawn in through the front of the Inverter/Charger to cool electronics for optimal performance.
14	Power On/Off Switch	This push button switch can be used to turn the unit on/off.
15	Remote Switch Terminals	Use this port to connect the optional remote on/off switch to the Inverter/Charger.



**WARNING!** Turning the unit off does not disconnect the batteries or the AC power source. The batteries will still charge if AC input is present.



**CAUTION!** This device does not include any output circuit breakers. Appropriately sized branch-rated circuit breakers must be installed in the output wiring (breaker panel).



**CAUTION!** The Advanced Inverter/Chargers internal transfer contacts are rated for 30 A for the AIC-2000-SL-12/AIC-3000-SL-12, and 50 A for the AIC-3000-DL-12. The pass-through current for relay contact must be no greater than this rating, or damage may occur.

1.5 DIMENSIONS

**Note**

The dimensioned drawing is not to scale.

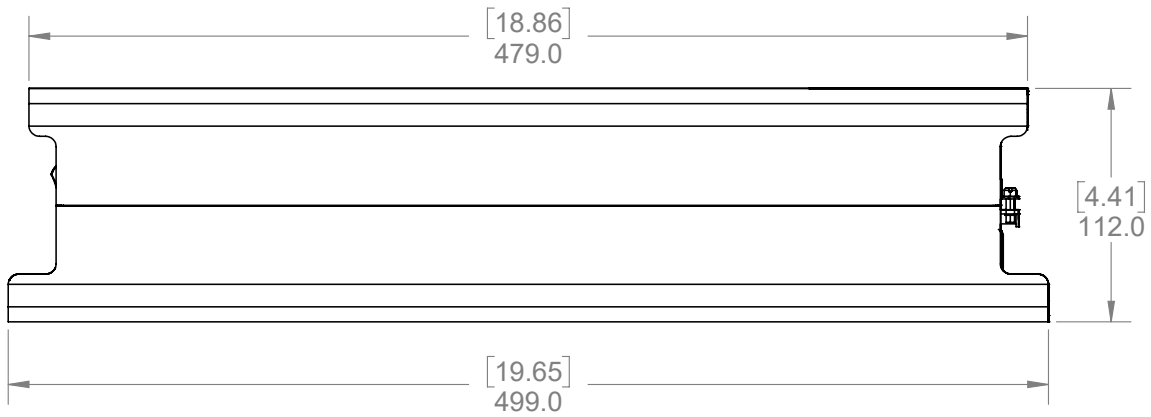
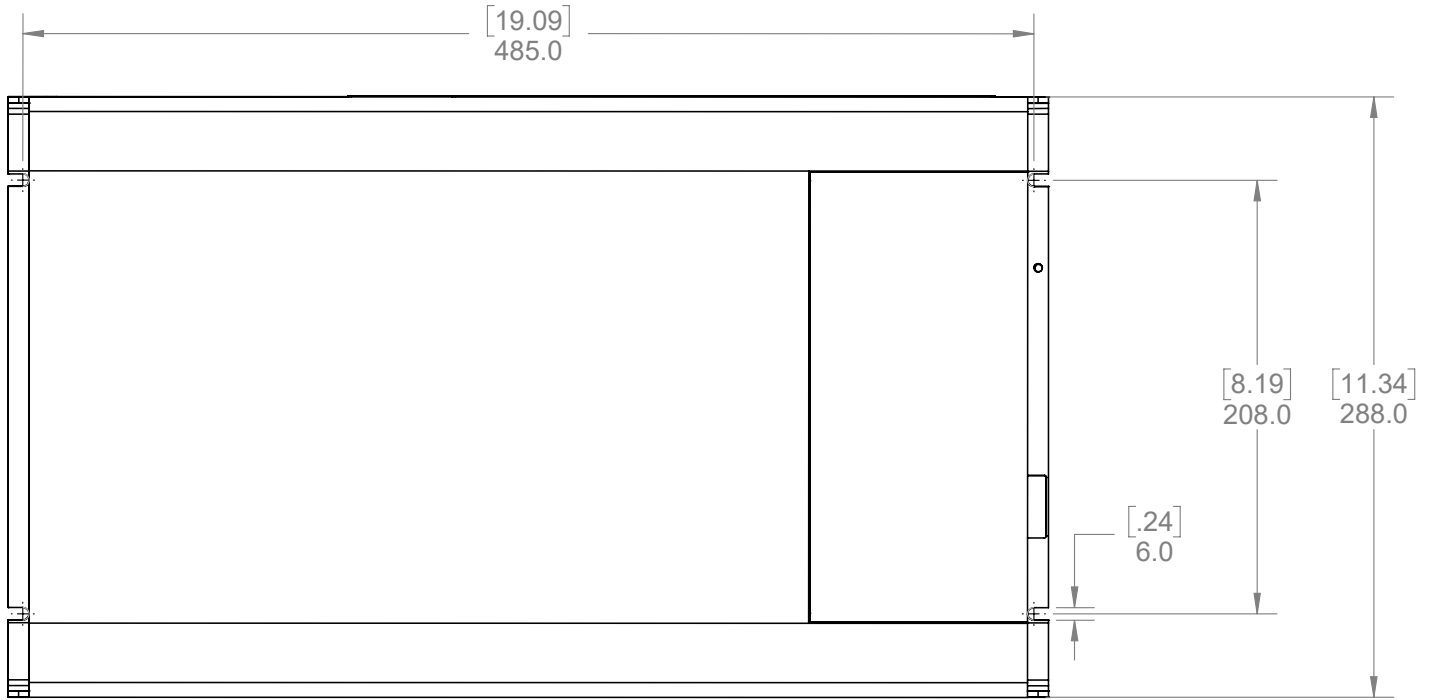

## 1.6 ACCESSORIES

The Advanced Inverter/Charger has the following accessories available.

### **BATTERY TEMPERATURE SENSOR (BTS)**

The battery temperature sensor (BTS) connects to the negative battery terminal and monitors the temperature of the battery bank. The temperature data is used to provide optimum battery charging even during extreme temperature changes. Refer to section 2.5.4 for more details on connecting and using the BTS.

### **POWERTRAK™ DISPLAY**

The PowerTrak™ Display (sold separately) is the remote required for controlling the settings and viewing system details on the Advanced Inverter/Charger. Refer to section 3.3 for more details on connecting and using the PowerTrak™ Display.

### **REMOTE SWITCH**

The remote switch (SSW-R, sold separately) is an on/off switch that can be mounted in an easily accessible location, at a distance from the Inverter/Charger. This allows the user to turn the Inverter/Charger on/off without accessing the unit. Refer to section 3.1 for more details on connecting and using the remote switch.

### **NETWORK CABLE**

The network cable (included with AIC-3000-DL-12) is not required for this product and may be discarded.

### **DC TERMINAL LUGS**

The DC M10 terminal lugs are heavy duty connectors included with the AIC. Use these to attach the recommended battery cables to the Inverter/Charger's DC input terminals. Refer to section 2.5 for more information on DC wiring.

### **POWER DISCONNECT HARNESS**

The Power Disconnect Harness (84283) is an RV-C harness included with the Inverter/Charger. Refer to section 2.7 for information on RV-C communications, and examples of system wiring diagrams.

## 2. INSTALLATION

### 2.1 REQUIRED TOOLS AND MATERIALS

- 15 mm (19/32") Socket
- Torque Wrench (or Ratchet with Torque Adapter) and Extension
- Phillips Screwdriver (#2)
- Wire Cutters
- Wire Strippers
- Wire Crimpers
- Heat Shrink Tubing
- Heat Gun
- DC Current Clamp
- Multimeter

### 2.2 LOCATION AND ENVIRONMENTAL REQUIREMENTS

The Advanced Inverter/Charger must be installed in a location that meets the following requirements.

#### 2.2.1 TEMPERATURE

Make sure the Inverter/Charger is installed in a location where the normal air temperature is between -20 °C and 60 °C. Lower temperatures within this range are preferred for optimal performance. The Inverter/Charger will start to derate in temperatures above 40 °C.

#### 2.2.2 MOISTURE

Do not allow water or other fluids to come into contact with the Inverter/Charger. Do not expose to rain, snow, or water.



**CAUTION!** “Installing the inverter in high moisture environments will accelerate corrosion. The service life of certain components will become compromised and not be covered by warranty.”

### 2.2.3 VENTILATION

For optimum performance the Inverter/Charger must be installed so the vents on both ends are not blocked or obstructed in any way. Do not install the Inverter/Charger in an area with limited air flow. Allow as much space around the Inverter/Charger as possible, leaving at least 6” of airspace clearance around all ventilation areas.



**CAUTION!** Do not mount the Inverter/Charger in a zero clearance compartment. Do not cover the ventilation openings. Overheating and mechanical failure may occur.

### 2.2.4 FIRE

Install the Inverter/Charger away from any flammable or combustible material (paper, flammable liquids, gasoline, cloths) that may be ignited by heat, sparks, or flames. Exercise caution when placing the Inverter/Charger directly above the battery bank. Some battery types may vent gases that can corrode and damage the Inverter/Charger. Make sure the battery space is ventilated when using the Inverter/Charger and lead-acid batteries in the same compartment. Never allow battery acid to drip onto the unit.

### 2.2.5 ACCESSIBILITY/ORIENTATION

Do not block access to the connection ports, status LEDs or the on/off switch. Allow enough room to remove the sliding terminal cover, as the connections will need to be checked periodically. The Inverter/Charger must be installed in one of the approved mounting orientations detailed on page 13.

### 2.2.6 CLEAN

The Inverter/Charger should be installed in a location which is clean and limits the introduction of dust, fumes, insects, or rodents that could enter and block the Inverter/Charger’s ventilation openings.

### 2.2.7 PROXIMITY TO BATTERY BANK

The Inverter/Charger should be located as close to the batteries as possible. The length and size of the DC cables will affect performance. Long DC wires will reduce efficiency and diminish overall performance of the Inverter/Charger. Use the DC cables recommended on page 15.

## 2.3 MOUNTING THE INVERTER/CHARGER

Prior to connecting any wires to the Inverter/Charger, the unit must be mounted securely in a location which meets the requirements detailed in section 2.2. It is recommended to use two people whilst mounting the unit. All mounting surfaces and hardware must be capable of supporting at least twice the weight of the Inverter/Charger. Inverter/Charger weights are listed in the table below.

MODEL	WEIGHT
AIC-2000-SL-12	20.6 lbs (9.34 kg)
AIC-3000-SL-12	21.1 lbs (9.57 kg)
AIC-3000-DL-12	21.7 lbs (9.84 kg)

The Inverter/Charger must be mounted on a noncombustible surface, in one of the orientations highlighted on page 13 to meet regulatory requirements.

After determining the mounting position, use the dimensions on page 10, or use the base of the Inverter/Charger to mark the mounting screw locations. Mount the unit with appropriate hardware for the mounting surface. Ensure the unit is fastened securely.



**HORIZONTAL MOUNT, BASE DOWN**

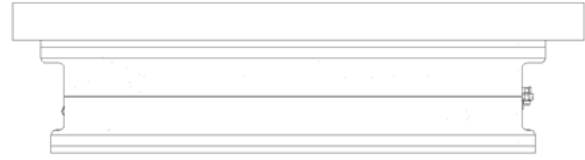

**HORIZONTAL MOUNT, BASE UP**



**WALL MOUNT, HORIZONTAL, TERMINALS RIGHT**



**WALL MOUNT, HORIZONTAL, TERMINALS LEFT**



**IMPORTANT** The Advanced Inverter/Charger cannot be wall mounted vertically.

## 2.4 GENERAL WIRING SPECIFICATIONS

The following sections detail how the Advanced Inverter/Charger should be wired. Read and understand these instructions before starting any wiring. Wiring should meet all local codes and standards and be performed by qualified personnel such as a licensed electrician. The NEC (National Electrical Code) and CEC (Canadian Electrical Code) provide the standards for safely wiring, wire sizes, over-current protection, installation methods, and requirements.

Advanced Inverter/Charger systems can handle power from multiple sources (utility, generator, and batteries) which make the wiring hazardous and challenging.

The input and output AC and DC circuits are isolated from the Inverter/Charger chassis. The Inverter/Charger grounding is the responsibility of the installer in accordance with NEC/CEC or the local electrical codes.

### 2.4.1 CABLE PROTECTION

All the DC and AC cables leading to/from the Inverter/Charger must be protected as required by code. This can be accomplished using jacketed (armored) cable or by feeding the wire through conduit.

### 2.4.2 CABLE STRAIN RELIEF & TORQUE REQUIREMENTS

The Inverter/Charger AC input and output terminals can handle cables up to 0.6 in (15.7 mm) in diameter for the AIC-2000-SL/AIC-3000-SL, and up to 1.0 in (26.5 mm) for the AIC-3000-DL.

Torque DC wiring connections to 177 in lbf (20 Nm) and ensure they are secure. Re-check all connections periodically (at least every 6 months; more frequently for heavy RV use) to make sure they remain secure.

### 2.4.3 CABLE REQUIREMENTS

- Protect all conductors that may be at risk of physical damage by using conduit, tape, or place them in a raceway.
- AC and DC over-current protection must be provided.
- The Inverter/Charger requires a reliable negative and ground return path to the battery using appropriately sized cables.
- Use only copper wires with the minimum temperature ratings specified in sections 2.5.1 (DC wiring) and 2.6.2 (AC wiring).

### 2.4.4 CABLE LAYOUT PLANNING

Prior to connecting any cables, determine all cable routes to/from the Inverter/Charger.

- AC input cables from the Inverter/Charger to the AC input source (this will vary depending on the set up, see section 2.6.2 for more details).
- DC cables from the Inverter/Charger to the battery bank.
- AC output cables from the Inverter/Charger to the AC output panel (main panel or sub panel).
- Battery temperature sensor cable from the Inverter/Charger to the battery bank (if applicable).
- PowerTrak™ Display RV-C harnessing to the Inverter/Charger (if applicable).
- Ground wiring to/from the Inverter/Charger.

## 2.5 DC WIRING

The DC cables connect the Inverter/Charger to the battery bank. These cables handle the direct current power used to charge the batteries (charging mode) and power the main appliances (inverting mode). It is important to select the correct wire size and to provide adequate over-current protection between the Inverter/Charger and the battery bank.

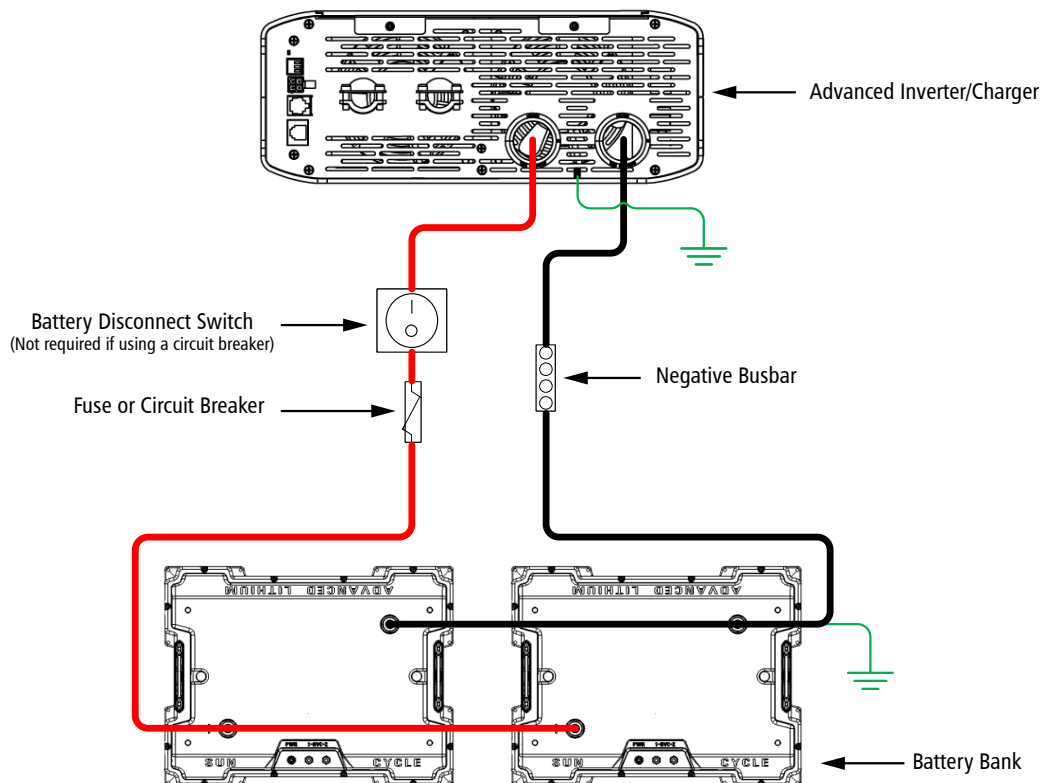

The following points must be observed for the DC wiring.

- The DC positive and negative cables connected to the Inverter/Charger from the battery bank should be secured using cable clamps and ties, with a 12 mm (0.5”) air gap maintained between the cables where possible. Routing the cables together helps to reduce radio frequency interference and reduces the effects of inductance, both of which improve the Inverter/Charger waveform and reduce the wear of the filter capacitors. Maintaining an air gap between the cables ensures they are unbundled in free air.
- To ensure optimum Inverter/Charger performance, the number of connections between the battery bank and the Inverter/Charger unit should be minimized except from the over-current and battery disconnect devices. All additional connection points will cause extra voltage drops.
- The battery bank voltage must match the DC voltage required by the Inverter/Charger, which is 12 V. Do not connect a 24 V, 36 V or 48 V battery bank to the Inverter/Charger.
- All DC cable terminations should use crimped and sealed copper ring terminal lugs. Lugs with a 10 mm (3/8”) hole should be used to connect the DC cables to the Inverter/Charger’s DC terminals.
- Make sure all cables have a smooth bend radius and no kinks are present.
- Colour code all DC cables coming to/from the battery bank. Use colored electrical tape or heat shrink tubing. Red for positive (+), black for negative (-), and green for DC ground.

## 2.5.1 DC WIRE SIZE AND OVERCURRENT PROTECTION

The distance between the battery bank and the Inverter/Charger should be as short as possible to maximize efficiency. The cables should be as short as possible and the overall length of each cable should be less than 10 ft (3 m) to comply with code requirements. Keeping your wire runs as short as possible helps to prevent low voltage shutdowns and nuisance tripping of the DC breaker from increased current draw. The table below shows the recommended DC cable sizes and fuses/circuit breakers for the Advanced Inverter/Chargers. These values are correct for unbundled cables in free air, with minimum temperature rating of 105 °C.

MODEL	DC CABLE SIZE	INLINE FUSE/CIRCUIT BREAKER	RECOMMENDED MAXIMUM LENGTH OF EACH CABLE	RECOMMENDED GP-DC-KIT
AIC-2000-SL-12	2/0 AWG	300 A Class T	10 ft (3 m)	GP-DC-KIT4
AIC-3000-SL-12	4/0 AWG	400 A Class T	10 ft (3 m)	GP-DC-KIT5
AIC-3000-DL-12	4/0 AWG	400 A Class T	10 ft (3 m)	GP-DC-KIT5

Batteries are capable of providing very large currents in case of a short circuit. If this occurs with no DC overcurrent protection, it will result in overheating and melting of the cables and possibly serious injury and/or fire.

DC overcurrent protection is not included with the Advanced Inverter/Charger. It must be installed between the Inverter/Charger and the battery bank for safety reasons and to comply with code regulations.

Use a very fast acting DC fuse or circuit breaker in the positive cable. The fuse should be installed as close as possible to the battery positive terminal. Ideally the fuse/circuit breaker should be installed within 18” (45 cm) of the battery. The fuse required for DC cable lengths up to 10 ft (3 m) is detailed in the above table.

A battery disconnect switch is required in all installations. If a circuit breaker is installed for overcurrent protection, this will suffice as a disconnect switch. If a fuse is installed for overcurrent protection, a separate appropriately rated disconnect switch is required.

### 2.5.2 PREPARING THE DC CABLES

Go Power! | Dometic supplies two ring lugs with the Advanced Inverter/Charger, which can be used for the Inverter/Charger end of the DC cables. Source the correct ring terminals for the batteries you are using.

- Cut the negative and positive cables to the required length.
- Strip off enough insulation to install the ring lugs.
- Use the correct wire crimper to install the ring lugs on both ends of both cables. Make sure no stray wire strands protrude from the connectors. Cover the crimped connections with heat shrink tubing.

### 2.5.3 DC CABLE CONNECTIONS

When installing the battery cable ring lugs onto the Inverter/Charger DC terminals and the battery terminals, do not put anything between the ring lug and the metal surface. Incorrectly installed hardware causes a high resistance connection which could lead to poor Inverter/Charger performance and may melt the cable and terminal connections. Periodically check the connections to make sure they remain tight and secure.

### 2.5.4 BATTERY TEMPERATURE SENSOR INSTALLATION

The battery temperature sensor (BTS) extends the life of the battery by preventing overcharging in warm temperatures and undercharging in cold temperatures. The BTS provides the Inverter/Charger with precise battery temperature information to automatically adjust the absorption and float charge voltage set points. If the BTS is not installed and the battery bank is subjected to large temperature changes, the battery life will be reduced.

**Note**

Lithium batteries do not require temperature compensation. The BTS does not need to be installed when using a lithium battery bank.

- Install the BTS ring terminal onto the negative battery terminal.
- Route the BTS cable to the Inverter/Charger following existing wire runs.
- Connect the RJ11 connector end of the BTS cable to the "BTS" port on the Inverter/Charger.

### 2.5.5 WIRING THE INVERTER/CHARGER TO THE BATTERY BANK



**WARNING!** High currents will be present if the positive and negative cables attached to the battery bank touch each other. During the installation and wiring process, ensure the cable ends are insulated or covered to prevent shorting the cables.



**WARNING!** DO NOT connect the DC wires from the battery bank to the Inverter/Charger until all the DC and AC wiring is complete and the AC and DC overcurrent protection and disconnect switch (if using a fuse) has been installed.

The Advanced Inverter/Chargers are designed to be used with a 12 V battery bank. The battery bank may be wired in series, parallel, or series-parallel to provide the correct voltage. The interconnecting wires between the individual batteries must be the same wire gauge or greater than those used between the battery bank and Inverter/Charger.

**Note**

To ensure the best performance from your Inverter/Charger system, batteries should be the same size, type, rating, and age. Do not use old or untested batteries.



**CAUTION!** The Inverter/Charger is not reverse polarity protected. If the Inverter/Charger is wired incorrectly severe damage will occur and will not be covered by the warranty. It is advised to clearly mark the positive and negative cables coming from the battery bank. Use red and black electrical tape to clearly indicate positive and negative cables.

## 2.5.6 DC POSITIVE AND NEGATIVE WIRES

- Remove the sliding terminal cover from the Inverter/Charger by loosening the captive screws.
- Route the negative cable from the battery bank negative terminal through the DC- labeled grommet on the Inverter/Charger end cap, and connect it to the negative terminal stud.
- Mount the DC circuit breaker or DC disconnect/fuse assembly and leave it open (no power to the Inverter/Charger).
- Connect the positive cable from the battery bank positive terminal to the circuit protection terminal.
- Route the positive cable from the circuit protection terminal through the DC+ labeled grommet on the Inverter/Charger end cap, and connect it to the positive terminal stud.
- Ensure the DC wire connections are flush on the surface of the DC terminals and tighten the nuts to 177 in lbf (20 Nm).
- Leave the sliding terminal cover off until the AC wiring is completed.
- Secure cables using cable clamps and ties. Ensure a 12 mm (0.5") air gap is maintained between cables.

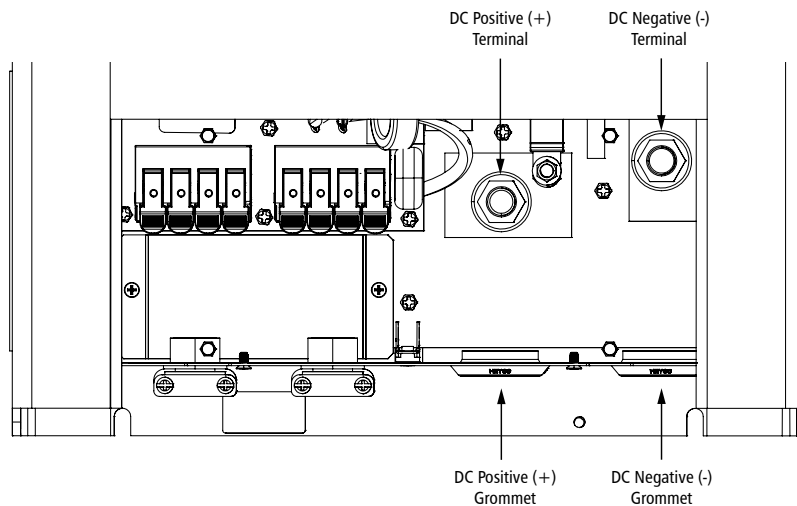
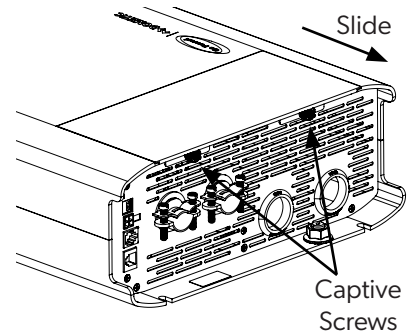

## 2.5.7 DC GROUNDING

To protect against electrical shock hazards, the metal Inverter/Charger chassis must be connected to the DC grounding system. The DC grounding system is sometimes referred to as the earth ground or another designated ground. For example, on an RV, the metal frame of the RV is designated as the negative DC ground/RV ground. On a boat, the ground is simply referred to as boat ground.

The Advanced Inverter/Charger consists of a DC and an AC system that are isolated through a transformer. These systems both require appropriate grounding.

The DC ground terminal on the Inverter/Charger is used to connect the exposed chassis of the Inverter/Charger to the DC grounding system. Use copper wire that is either bare or provided with green insulation. The ground terminal stud accepts M10 (3/8") ring terminals. The size of the conductor should be coordinated with the size of the over-current devices used. In marine applications, the DC ground wire has to be the same size as the battery negative cable. The connection should be tightened to 177 in lbf (20 Nm).

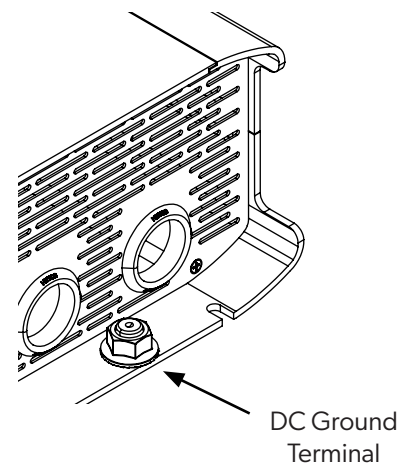

DC grounding involves proper grounding of the negative terminal of the battery, the DC panel, and the DC side of the Inverter/Charger. The DC panel is normally used to connect the batteries and distribute DC power to the Inverter/Charger and to the other DC loads.

A common earth ground should be used to bond the Inverter/Charger, negative bus bar, and the negative battery terminal.

**Note** All connections must be tight against bare metal. Use star washers to penetrate paint and corrosion.

## 2.6 AC WIRING

The AC cables connect the Inverter/Charger to the main panel and/or the sub panel. These cables handle the incoming alternating current (AC) utility or generator power which can be passed through the Inverter/Charger to directly power the main appliances (pass-through mode) and/or used to charge the batteries (charging mode). It is important to select the correct wire size and to provide adequate over-current protection between the Inverter/Charger, input source and output panel.

The following points must be observed for the AC wiring:

- Review the safety information at the start of this manual before completing any AC wire installation steps.
- All AC wiring must be approved for the application (RV, marine, residential). For RV applications, this may be solid wire in multi-conductor cables, but stranded wire is required if single conductors are used.
- All AC wiring must be rated to 90 °C or higher.
- Do not connect the AC output to an AC power source (generator/shore power). Severe damage may occur and will not be covered under the warranty.
- Always use properly rated circuit breakers/fuses.
- Color code and label all AC cables coming to/from the Inverter/Charger. Use colored electrical tape or heat shrink tubing.
- Make sure all cables have a smooth bend radius and no kinks are present.
- Secure all wiring using cable clamps and ties.

### 2.6.1 AC POWER SOURCE TYPES

The Advanced Inverter/Charger models offered by Go Power! | Dometic include dual leg and single leg variants. The compatible AC power source types vary depending on the Inverter/Charger model type.

AC input power to the dual leg Advanced Inverter/Charger can be supplied from a split-phase or dual-input single-phase AC source. These sources typically include utility power or a generator. Refer to section 2.6.3 to see the configuration of the dual leg AC input terminals.

- **Split-phase:** This source has four lines: two hot lines (L1 and L2), one neutral (N) and one ground (G). The two hot lines are 120 VAC and are 180 degrees out of phase with each other, so that the two voltages equal 240 VAC. The voltage between each hot line and neutral is 120 VAC. Since the two lines are out of phase, the currents from each line subtract in the neutral, and the neutral current will be approximately zero if the loads on each line are equal. For example, if L1 is supplying 20 A and L2 is supplying 15 A, the current in the neutral will be 5 A.
- **Dual-input single-phase:** This source has four lines: two hot lines (L1 and L2), one neutral (N) and one ground (G). The two hot lines are 120 VAC, are in phase, and must come from the same source. The voltage between the two hot lines is zero. The voltage between each hot line and the neutral is 120 VAC and the voltage between the neutral and the ground is approximately zero. Since the two lines are in phase, the currents from each line add together in the neutral. For example, if L1 is supplying 20 A and L2 is supplying 15 A, the current in the neutral will be 35 A.

AC input power to the single leg Advanced Inverter/Charger can only be supplied from a single-phase AC source. Refer to section 2.6.3 to see the configuration of the single leg AC input terminals.

- **Single-phase:** This source has three lines: one hot line (L), one neutral (N) and one ground (G). The voltage of a single-phase AC source is 120 VAC.

## 2.6.2 AC WIRE SIZE AND OVERCURRENT PROTECTION

The wires used for the AC input and output must be sized to meet local electrical safety requirements. The AC wiring must be protected from short circuits and overloads by an overcurrent protection device. These requirements are usually met using a main panel and/or sub panel with suitable circuit breakers/fuses installed. If the system uses a main panel and a sub panel, the main panel should be connected to the Inverter/Charger AC input, and the sub panel should be connected to the AC output. Refer to sections 2.6.5 and 2.6.7 for wiring details. If the system uses a main panel, but no sub panel, the main panel should be connected to the Inverter/Charger AC output. Refer to sections 2.6.6 and 2.6.8 for wiring details.

The table below shows the recommended AC cable sizes and circuit breaker sizes for the Advanced Inverter/Chargers. These values are correct for unbundled cables in free air, with minimum temperature rating of 90 °C.

MODEL	AC WIRE SIZE	CIRCUIT BREAKER SIZE
AIC-2000-SL-12	10 AWG	30 A
AIC-3000-SL-12	10 AWG	30 A
AIC-3000-DL-12	6 AWG	50 A



**CAUTION!** The Advanced Inverter/Chargers internal transfer contacts are rated for 30 A for the AIC-2000-SL-12/AIC-3000-SL-12, and 50 A for the AIC-3000-DL-12. The pass-through current for relay contact must be no greater than this rating, or damage may occur.

The Inverter/Charger will limit the AC input current based on the shore breaker size setting, which is set to 30 A by default. This setting can be changed by using the PowerTrak™ Display (sold separately). The shore breaker size must be set equal to or less than the shore breaker being used. For example, if a 15 A source is connected to the AC input, but the shore breaker size setting on the Inverter/Charger is set to 30 A, it will attempt to pull 30 A and trip the 15 A breaker. If the shore breaker size setting on the Inverter/Charger is set to 15 A, the device will limit the AC input current to 15 A.

### 2.6.3 AC TERMINAL BLOCK CONNECTIONS

The Advanced Inverter/Charger models offered by Go Power! | Dometic include dual leg and single leg variants. The AC terminal block connections will vary depending on the Inverter/Charger model type.

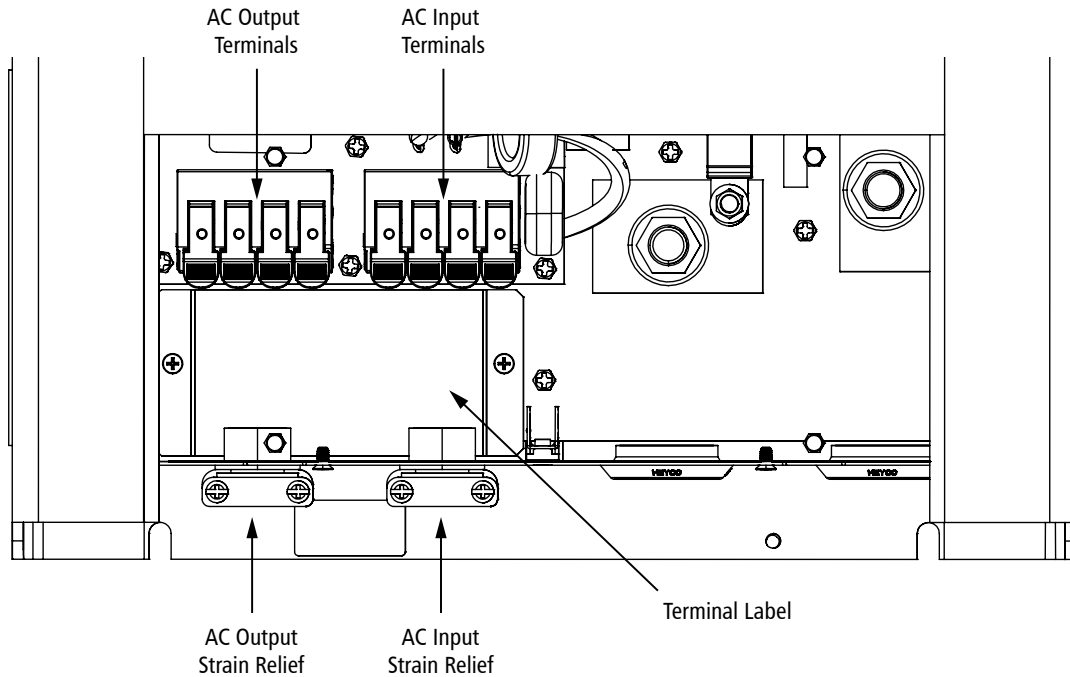

The dual leg Advanced Inverter/Charger has two four-pole terminal blocks to connect the AC input and output wiring. The single leg Advanced Inverter/Chargers have two three-pole terminal blocks to connect the AC input and output wiring. Refer to the diagrams below, or the terminal ID label located in front of the terminal blocks on the Inverter/Charger for wiring details. Each connection on the AC terminal block is rated to accept maximum 4 AWG wire.

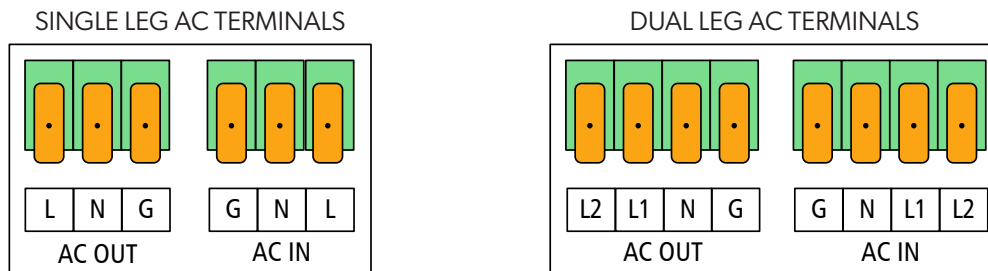

The AC terminal blocks feature push-in cage clamps. To insert wires, lift the orange lever until it is perpendicular with the terminals and insert the wire into the terminal. Push in the wire as far as the terminal will allow. Press down on the orange lever to lock the wire in place. Ensure the wire is securely inserted by pulling back firmly on it.

The Advanced Inverter/Charger's AC input neutral and AC output neutral terminals are electrically isolated from each other when in inverting mode, which helps to prevent ground-loops.

## 2.6.4 AC CONDUCTOR WIRING



**WARNING!** Make sure the Advanced Inverter/Charger is fully disconnected from the battery bank (circuit breaker or DC disconnect is open) and no AC power is connected to the Inverter/Charger before starting the AC wiring.

**Note**

The use of hot/live 2 (L2) only applies to the dual leg version of the Inverter/Charger. If you are using a single leg version, ignore the mention of hot/live 2 (L2) in the wiring instructions.

**Note**

The AC input source and output panel will vary depending on the system set up. Refer to the wiring diagrams in sections 2.6.5 to 2.6.8 for clarity.

### AC INPUT WIRING

- Remove the sliding terminal cover if it isn't already removed.
- Route the wires: hot/live 1, hot/live 2, neutral, and ground from the input source (main panel, transfer switch, shore power, etc.) to the Inverter/Charger, through the AC input strain relief clamp.
- Connect the hot/live 1 wire (black) from the input source to the AC input "L1" terminal. Connect the hot/live 2 wire (red) from the input source to the AC input "L2" terminal. Note: To enable the battery charger, L1 must be connected to an AC input source.
- Connect the neutral (white) wire from the input source to the AC input "N" terminal.
- Connect the ground (bare copper or green) wire from the input source to the AC input "G" terminal.
- Tighten the strain relief clamp securely on the wires. Always leave extra slack in the wiring.

### AC OUTPUT WIRING

- Route the wires: hot/live 1, hot/live 2, neutral, and ground from the output panel (main panel or sub panel) to the Inverter/Charger, through the AC output strain relief clamp.
- Connect the hot/live 1 wire (black) from the output panel to the AC output "L1" terminal. Connect the hot/live 2 wire (red) from the output panel to the AC output "L2" terminal.
- Connect the neutral (white) wire from the output panel to the AC output "N" terminal.
- Connect the ground (bare copper or green) wire from the output panel to the AC output "G" terminal.
- Tighten the strain relief clamp securely on the wires. Always leave extra slack in the wiring.

### AC WIRING CHECKS

- Ensure the wires are securely inserted in the terminal blocks by pulling back firmly on the wires.
- Ensure the strain relief clamps are tightened securely, with extra slack in the wiring.
- Ensure all wires are routed securely using cable clamps and ties.
- Ensure additional strain reliefs or grommets are in place to prevent damage to the wiring or conduit where it passes through the walls/bulkheads or other openings.
- After checking all AC connections and ensuring all the wires are secured, replace the sliding terminal cover and tighten the captive screws. Replace all the covers on the main and/or sub panels.

2.6.5 AC WIRING - SINGLE PHASE, 30 A SERVICE, SUB PANEL

**Note**

The hot/live 2 (L2) label on the input and output terminal blocks only applies to the dual leg version of the Inverter/Charger. If you are using a single leg version, ignore the hot/live 2 (L2) label in the diagram.

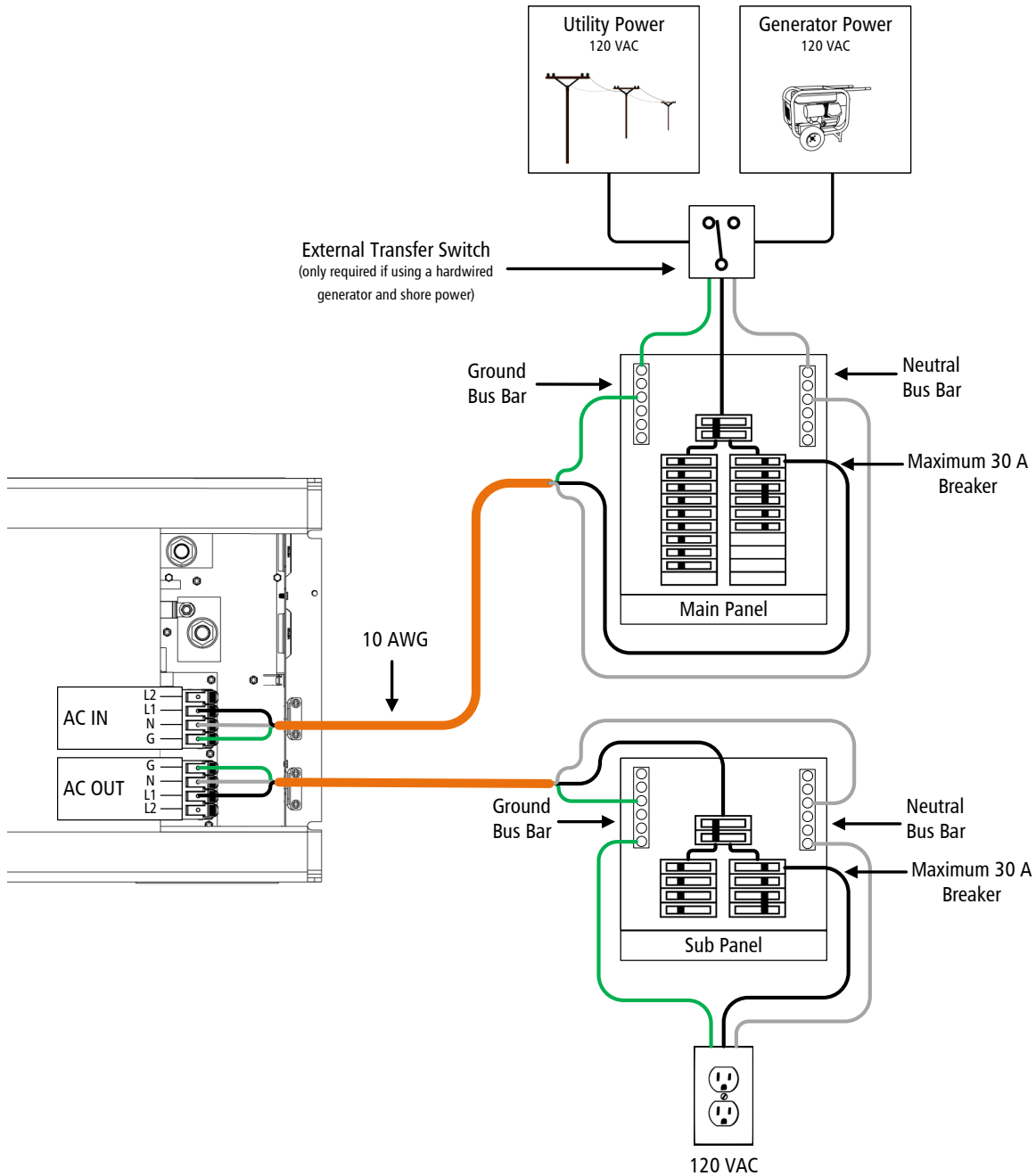

## 2.6.6 AC WIRING - SINGLE PHASE, 30 A SERVICE, NO SUB PANEL

**Note** The hot/live 2 (L2) label on the input and output terminal blocks only applies to the dual leg version of the Inverter/Charger. If you are using a single leg version, ignore the hot/live 2 (L2) label in the diagram.

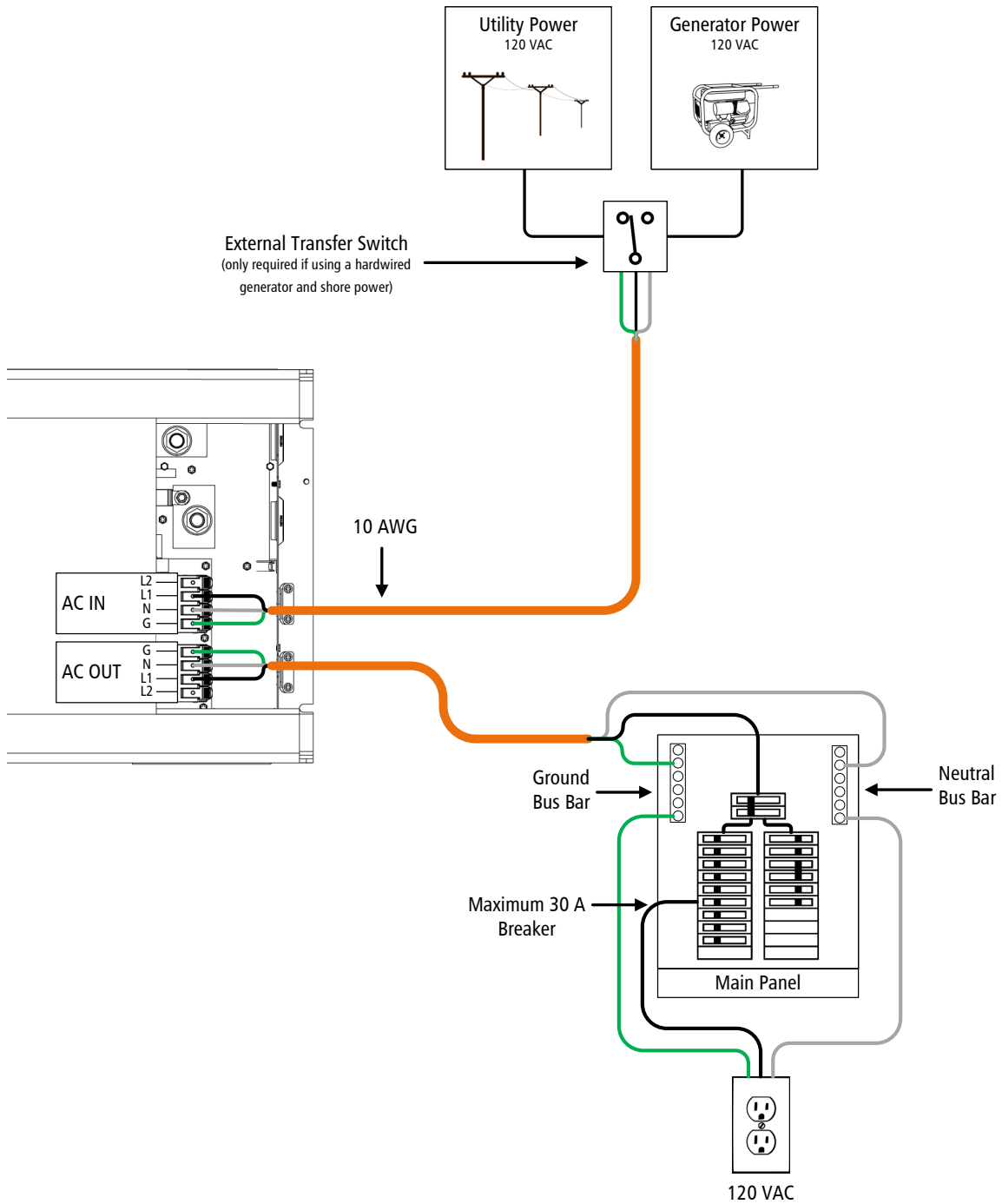

2.6.7 AC WIRING - SPLIT PHASE, 50 A SERVICE, SUB PANEL

**Note** This configuration is only valid for the dual leg version of the Inverter/Charger. In AC pass-through mode, 240 VAC is available across L1 and L2 when connected to a 120/240 VAC split-phase input source. In inverter mode, the Inverter/Charger supplies 120 VAC on both lines (L1 and L2), resulting in zero voltage difference between them.

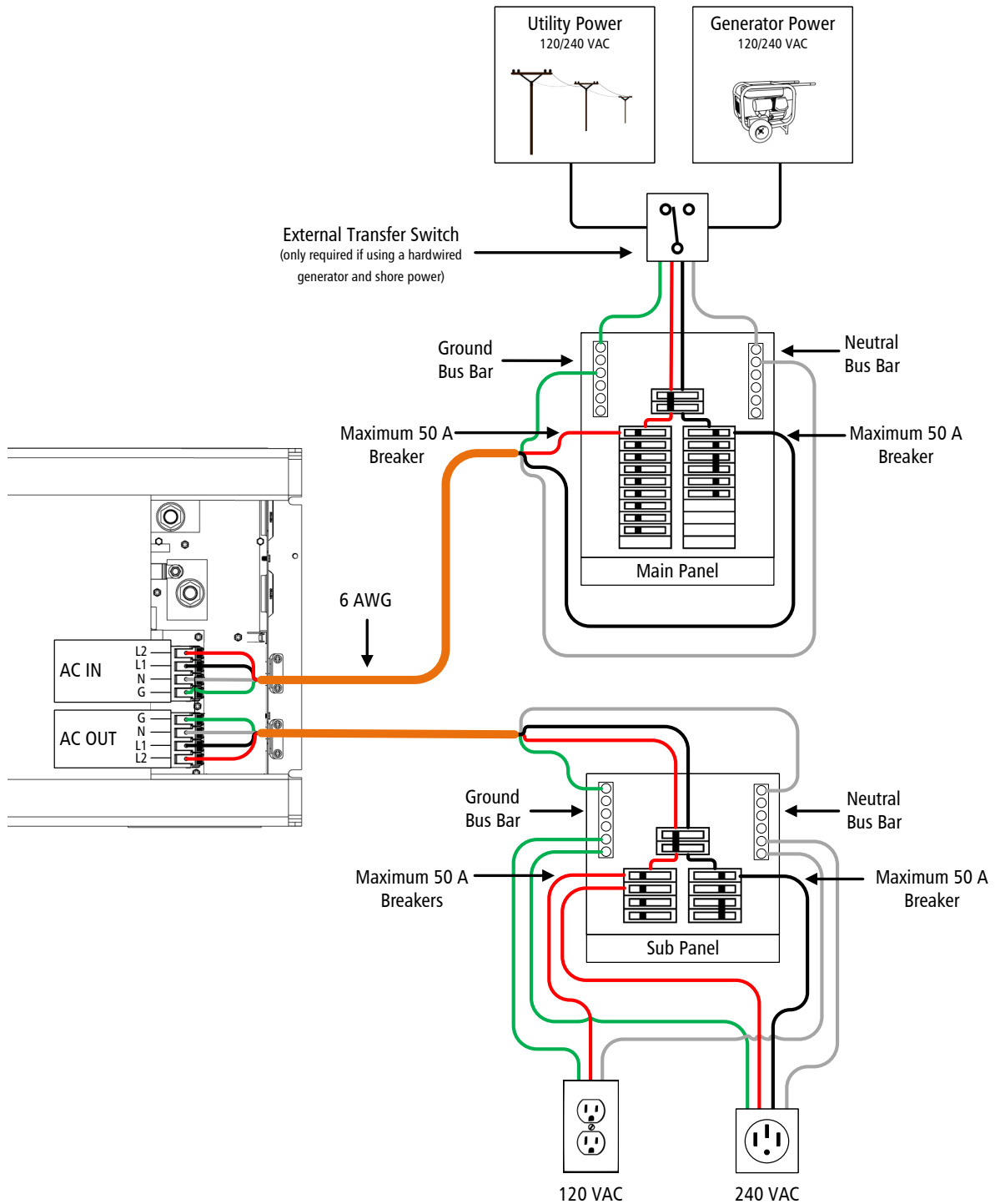

## 2.6.8 AC WIRING - SPLIT PHASE, 50 A SERVICE, NO SUB PANEL

**Note** This configuration is only valid for the dual leg version of the Inverter/Charger. In AC pass-through mode, 240 VAC is available across L1 and L2 when connected to a 120/240 VAC split-phase input source. In inverter mode, the Inverter/Charger supplies 120 VAC on both lines (L1 and L2), resulting in zero voltage difference between them.

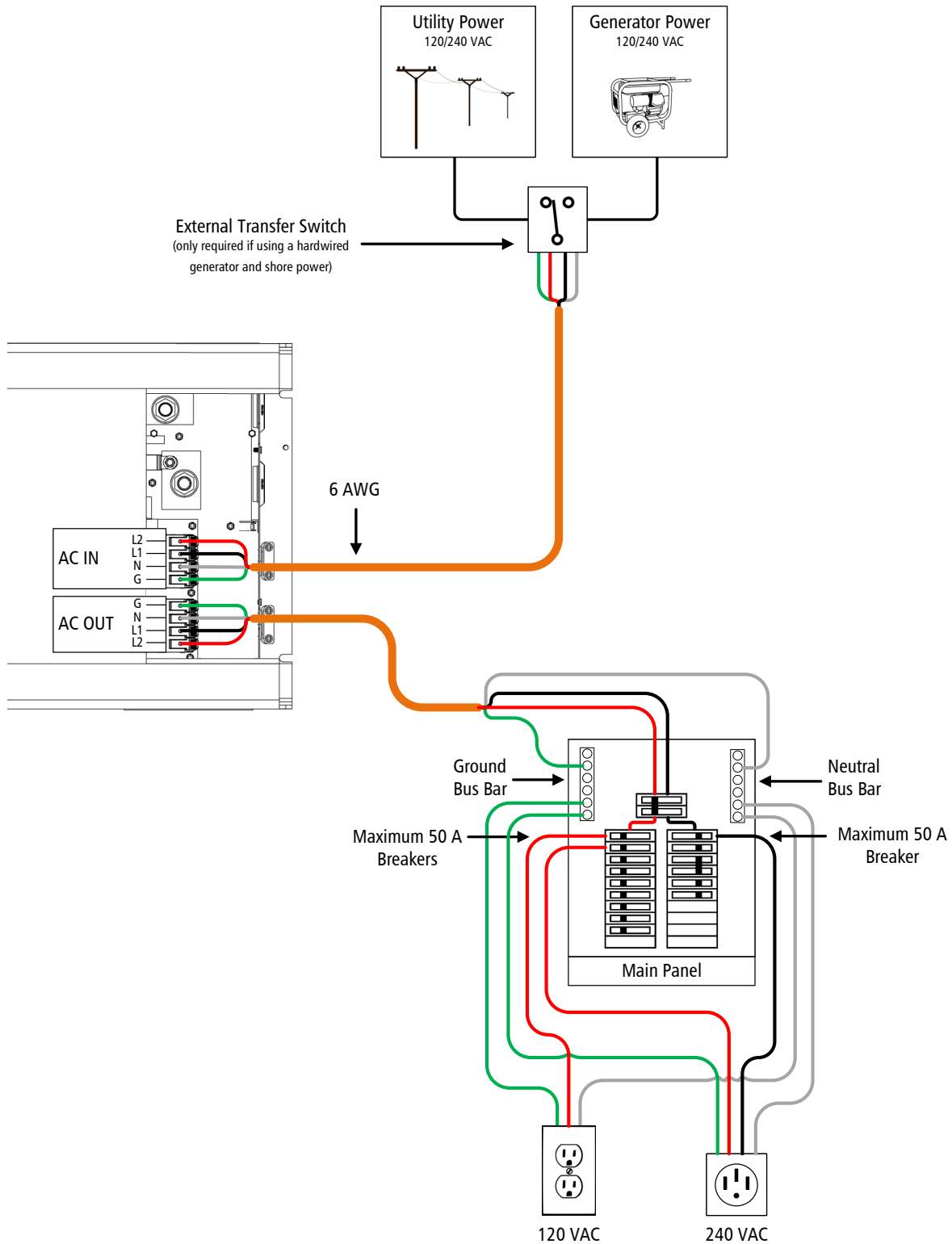



### 2.6.9 GROUNDING THE INVERTER - AC GROUNDING

The Advanced Inverter/Charger should always be connected to a permanent, grounded wiring system. An Inverter/Charger system that is properly grounded will reduce the risk of electric shock, and reduce radio frequency noise. The main goal of any grounding system is to provide a well defined, very low resistance path from the electrical system to the grounding system. The low resistance grounding path carries fault currents directly to ground if the electrical system malfunctions.

The neutral and safety ground should be connected at the AC source. The AC source could be shore power (utility power), generator or the inverter (battery bank). The AC neutral should be connected to one safety ground at a time. This single connection is required to make the electrical panels neutral line safe by connecting it to ground. If more than one connection between the neutral and ground is made, currents can circulate between neutral and ground and cause ground loop currents. Ground loop currents can trip GFCIs and cause an electric shock hazard.

When using the Inverter/Charger in inverting mode and when using multiple other AC power sources (utility or generator power), there is the potential of having multiple connections between neutral and ground. The Inverter/Charger automatically disconnects the neutral from ground when switching from inverting to AC pass-through mode.

In inverting mode, the AC neutral output is connected to the chassis ground on the Inverter/Charger, which is usually connected to the earth ground on the RV, work truck, or boat.

In AC pass-through mode, the chassis ground to neutral output on the Inverter/Charger is disconnected and the AC power source neutral to ground (usually located at utility panel or generator) is used to provide the neutral to ground for the AC power being used in the RV, work truck, or boat

### 2.6.10 GROUNDING ON BOATS

If the Advanced Inverter/Charger is being installed on a boat, there are some specific guidelines/standards to follow. The Inverter/Charger must be installed adhering to the standards of the ABYC (American Boat and Yacht Council). Some guidelines are outlined below but these notes do not replace the full guidelines detailed in the ABYC standard. Always install the Inverter/Charger using the ABYC standard as the primary reference.

#### **Safe AC and DC Ground Connection**

As detailed in the last section, when the AC power source is being supplied by shore power (marina) the onboard neutral must be connected to the safety ground on the dock. This feature is automatically taken care of by the Inverter/Charger. When the AC power source is being supplied by the inverter (battery bank) the onboard neutral must be connected to the common boat ground. The DC ground terminal must also be connected to the common boat ground. This ensures that both the AC and DC ground are connected to one common boat ground.

#### **Corrosion**

The Inverter/Charger's AC and DC terminals must be connected to the common boat ground to provide an important safety feature. This ground connection can introduce the risk of galvanic corrosion and/or electrolysis of the boat's underwater metallic hardware. A galvanic isolator or an onboard isolation transformer can be used to prevent galvanic corrosion.

## 2.7 RV-C COMMUNICATION

The RV-C connector is a standard RV-C Molex connector with the pinout shown below. Use this to connect the Inverter/Charger to the RV-C network and other RV-C devices, like the PowerTrak™ Display.



**IMPORTANT** The Inverter/Charger supplies power to the RV-C network. Go Power! | Dometic recommends using the battery as the power source for the RV-C network, and disabling the power connection to all other power sources, including the Inverter/Charger, with the power disconnect cable (84283). Refer to the wiring diagrams in section 2.7.1 for more details.

1	2	3	4
CAN H	CAN L	GND	+15 V Supply (250 mA max)

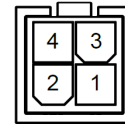

### 2.7.1 DEVICE CONNECTION

The PowerTrak™ devices are connected via RV-C harnessing (sold separately). The RV-C harnesses are connected to the RV-C port on the Inverter/Charger. The following points must be observed for the RV-C harnessing.

- The system must have two terminating resistors, one at each end of the network. The adapter harness (83438) included with the PowerTrak™ Display has a terminating resistor built in. The second terminating resistor must be added to the opposing end of the network, using the terminating resistor harness (83543). This harness can be easily identified by the orange “TERMINATING RESISTOR” label.
- Go Power! | Dometic recommends using the battery as the power source for the RV-C network, and disabling the power connection from all other power sources. The power disconnect harness (84283) must be connected to any component that supplies power to the RV-C network, excluding the battery. This harness can be easily identified by the green “POWER DISCONNECT” label.

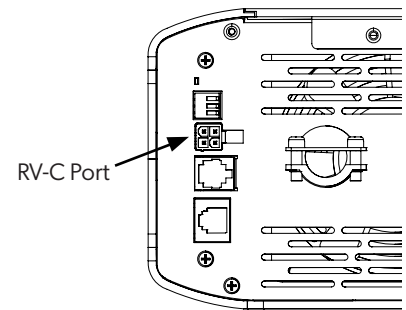

The following wiring diagram shows the recommended RV-C harness connections for systems with an Advanced Inverter/Charger paired with a PowerTrak™ Display and an Advanced Lithium Battery.

**Note** The adapter harness (83438) is included with the PowerTrak™ Display. All other RV-C harnesses must be purchased separately from Go Power! | Dometic.

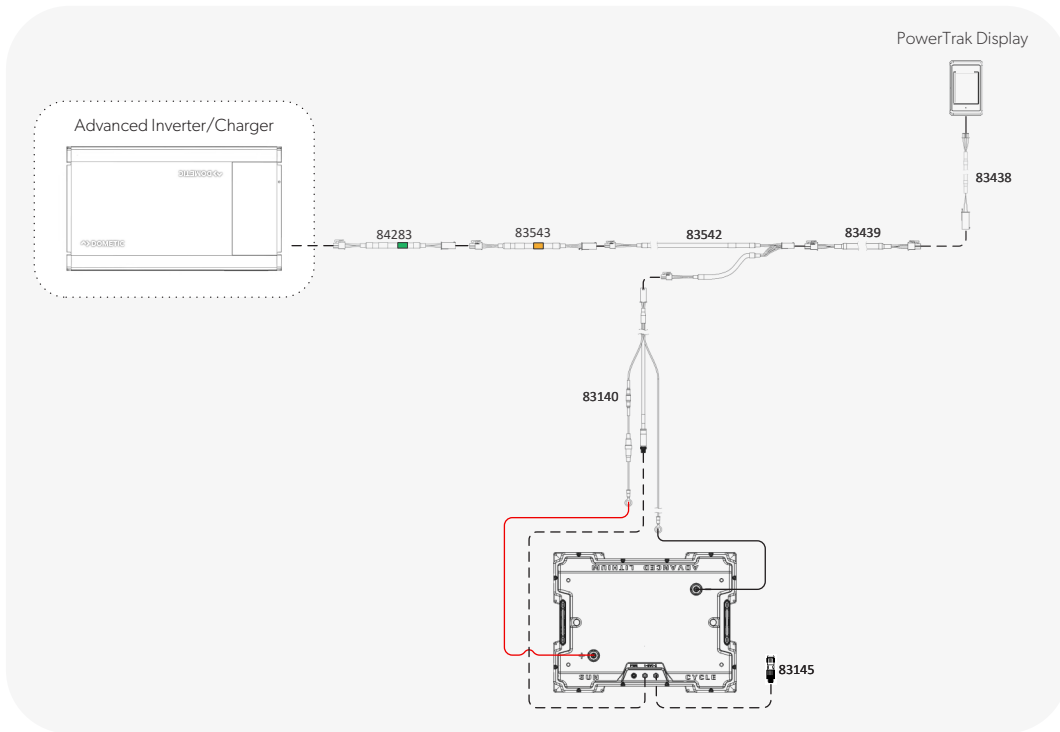

The following wiring diagram shows the recommended RV-C harness connections for systems with an Advanced Inverter/Charger paired with a PowerTrak™ Display and a battery without RV-C support. In this system, the M8 connector on the battery connection harness (83140) can remain unconnected.

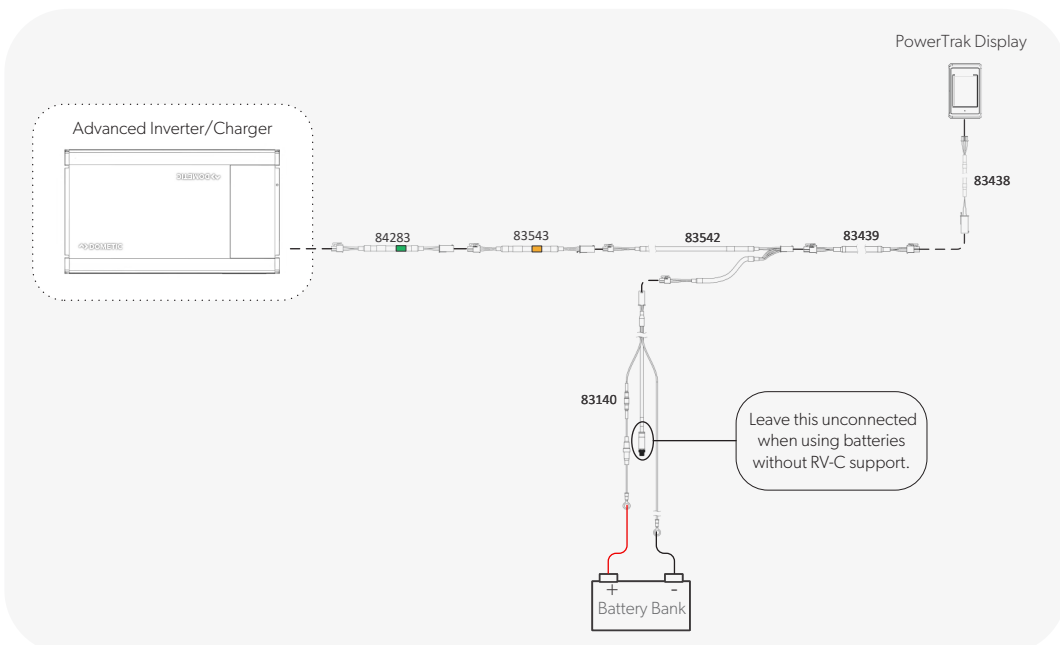

Other examples of PowerTrak™ compatible devices include the Go Power! | Dometic MPPT 30 A and 40 A Solar Controllers. A wiring diagram for an example system including these devices is shown below.

**Note** 5ft extension harnesses (83636) are available for purchase if required between components.

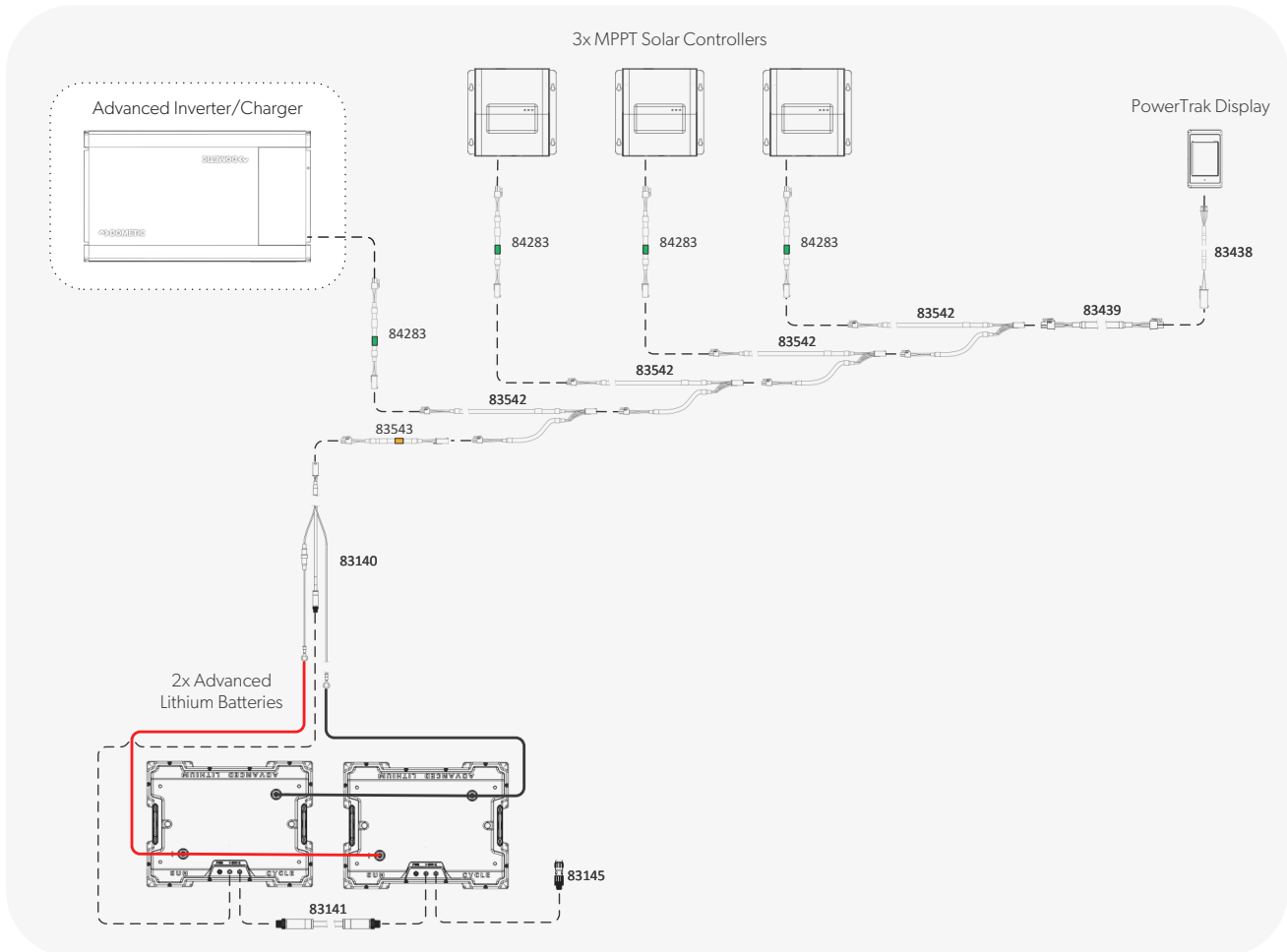

If your power system contains other RV-C compatible devices, you may require a different combination of RV-C harnesses. Please refer to our RV-C configurator through the QR code below to determine which cables are required for your system. Contact technical support if you are unsure about the RV-C requirements for your system.



Scan the QR code to access the Go Power! PowerTrak™ Part Configurator.

## 2.8 RV-C INSTANCE NUMBERS

The DIP switches on the Inverter/Charger are for setting the device RV-C instance numbers. This is how devices are distinguished on the RV-C bus. Refer to the table below to set the RV-C instance numbers. If you have multiple Inverter/Chargers in your system, make sure they each have a unique RV-C instance number.

RV-C INSTANCE NUMBER	DIP 1	DIP 2	DIP 3
1	ON	OFF	OFF
2	OFF	ON	OFF
3	ON	ON	OFF
4	OFF	OFF	ON
5	ON	OFF	ON

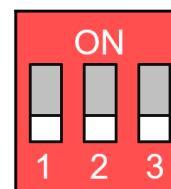

## 2.9 FINAL INSPECTION

1. Verify all cables/conduit runs are secured with zip ties or other non-conductive cable clamps to prevent damage from vibration.
2. Ensure all cables that pass-through walls, bulkheads, or any other openings are protected against abrasion by using strain reliefs and/or grommets.
3. Confirm all AC, DC and ground connections are secure.
4. Confirm the RV-C cables are securely installed.
5. Check the AC terminal connection cover plate has been securely re-attached.
6. Check all connections are secure in the main and sub panels. Replace all covers.
7. If required by code, have the installation inspected by an electrical inspector.

## 2.10 TESTING THE INSTALLATION

1. Disconnect AC input from the Inverter/Charger by switching off the input breakers or disconnecting the AC input source (utility or generator).
2. Disconnect AC output from the Inverter/Charger by switching off the output breakers in the AC panel.
3. Apply battery power to the Inverter/Charger by switching on the DC breaker or the DC battery disconnect switch. The device will remain off.
4. Turn on the Inverter/Charger by switching the power on/off switch to the on position. Verify the device turns on and its status LED indicator is not red.
5. Measure the voltage at the AC output terminals with a multimeter. Verify 120 VAC is measured.
6. Apply AC input to the Inverter/Charger by switching on the input breakers or connecting the AC input source (utility or generator).
7. Use a DC current clamp to measure the charge current on the DC cables between the Inverter/Charger and the battery bank. Verify the battery bank is charging.
8. Turn on the AC loads by switching on the output breakers in the AC panel.
9. Verify the AC loads are powered.
10. Disconnect the AC input. The AC loads and the inverter should remain on. The AC loads are now being powered by the inverter (battery bank).
11. Now that the functionality is confirmed, the system can be re-assembled, and all the breakers can be switched on.

### 3. OPERATION

#### 3.1 POWER ON/OFF

When the Inverter/Charger is first connected to the battery bank, the power on/off switch must be switched to the on position to turn the device on. The on/off switch only controls the AC output. This means if the switch is in the off position, the batteries can still charge when AC input is present. However, AC pass-through mode and inverter mode are only available when the on/off switch is in the on position.

The remote switch (sold separately) can be mounted in an easily accessible area, at a distance from the Inverter/Charger. This allows the user to turn the Inverter/Charger on/off without accessing the unit. If the remote switch and the power on/off switch on the device are both off, the Inverter/Charger is off. If either of the switches are on, the Inverter/Charger is on. Therefore, if the remote switch will be used as the main power switch, the power on/off switch on the device should be in the off position. Refer to the table below for more details.

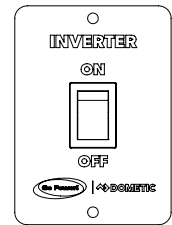
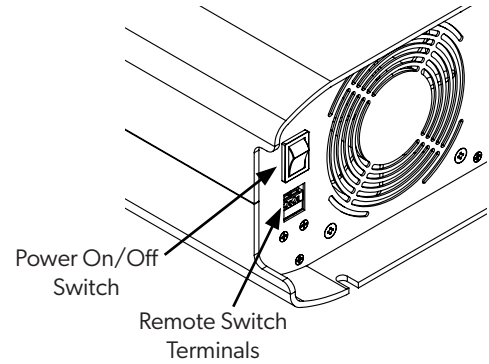

Remote Switch (SSW-R)

POWER ON/OFF SWITCH	REMOTE SWITCH	AC INPUT	AC OUTPUT	CHARGER	DEVICE STATE/DESCRIPTION
Off	Off/Not installed	No	Not available	Not available	Completely powered off.
		Yes	Not available	Available	Device is on. Charger may be enabled but there is no AC output.
On	Off/Not installed	No	Available	Not available	Device is on. AC output may be enabled, but the charger is not available.
Off	On				
On	On				
On	Off/Not installed	Yes	Available	Available	Device is on. AC output and charger can both be enabled.
Off	On				
On	On				

#### 3.2 STATUS LED INDICATOR

MODE	LED STATUS	DEFINITION
Inverter Mode or AC Pass-through Mode	Green	AC output is live from either the inverter or AC pass-through.
Charger Mode	Blue	The charger is enabled and will charge the battery bank if an AC input is present.
Inverter/Charger Mode	Blue/Green	The charger is enabled and AC output is live.
Standby Mode	White	The device is on, but AC output is not live and the charger is disabled.
Fault LED	Red	Indicates a fault is present. Refer to section 3.15 for fault condition details and troubleshooting.
Critical Fault	Flashing Red	Indicates a critical failure. Contact technical support at 1-866-247-6527.
Off	Off	The device is not powered.

### 3.3 POWERTRAK™ DISPLAY

The PowerTrak™ Display is the remote required for controlling the settings on the Advanced Inverter/Charger and viewing system details. The Advanced Inverter/Charger and the PowerTrak™ Display (sold separately) are compatible with the Go Power! | Dometic PowerTrak™ system. The PowerTrak™ system technology ensures compatible devices work together to optimize power flow and efficiency. This section will outline connection and basic operation of the PowerTrak™ Display. For more details, please use the QR code below to access the user manual for the PowerTrak™ Display.



Scan the QR code to access the PowerTrak™ Display user manual.

#### 3.3.2 DISPLAY POWER-UP

The PowerTrak™ Display is powered from the RV-C network, and automatically turns on when connected to the system. A message is displayed that a search for connected devices is in progress.

Confirm the Inverter/Charger is loaded on the screen, along with any other components that are in your system.

**Note**



If more than one Inverter/Charger is installed in the system, the load screen should indicate the number of units detected.

- Press the **LOAD** button.

#### 3.3.3 OPENING THE DISPLAY SETTINGS

- Press the  button to open the settings.

#### 3.3.4 SWITCHING THROUGH THE SETTINGS

- Press the arrow buttons to switch through the settings pages.
- Press the  button in the top left corner of the display to switch to the previously displayed screen.
- Press the  button to display the home screen.

#### 3.3.5 INVERTER SETTINGS

- Press the “Inverter Settings” button on the settings screen.
- Refer to section 3.13.1 for more details on the available settings.

#### 3.3.6 CHARGER SETTINGS

- Press the “Charger Settings” button on the settings screen.
- Refer to section 3.13.2 for more details on the available settings.

## 3.4 BATTERY TYPE

The Advanced Inverter/Charger is suitable for use with lead acid batteries (vented, GEL, or AGM type) as well as lithium iron phosphate (LiFePO4) batteries that are supplied with a battery management system (BMS).

A custom profile in the settings allows creating a specific battery profile by programming and adjusting various charging parameters such as the charging voltage set points.

## 3.5 BATTERY CHARGER SPECIFICATIONS

The Advanced Inverter/Charger is equipped with a power factor corrected (PFC) and proportional integral (PI) multistage battery charger. These two features maximize the real power from the AC input. The multistage battery charger can use up to four different charging stages to help monitor and keep the batteries healthy.

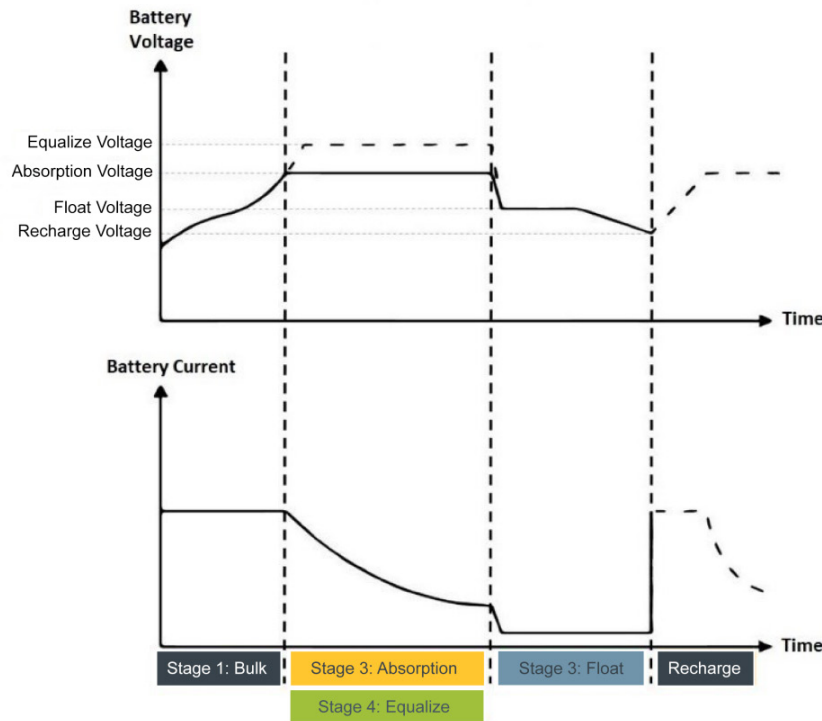

### 3.5.1 FIRST STAGE: BULK

This is the initial stage of charging. While bulk charging, the charger supplies the battery bank with controlled constant current. The charger will remain in bulk charge until the absorption charge voltage is achieved.

### 3.5.2 SECOND STAGE: ABSORPTION

This is the second charging stage, and it begins after the absorption voltage has been reached. Absorption charging provides the batteries with a constant voltage and reduces the DC charging current in order to maintain the absorption voltage setting. The factory default setting for absorption charging is 2 hours. After 2 hours of absorption charging, the charger switches to float charging.

### 3.5.3 THIRD STAGE: FLOAT

The third charging stage occurs at the end of the absorption charge. While float charging, the charge voltage is reduced to the float charge voltage set point. In this stage, the batteries are kept fully charged and ready if needed by the inverter. The float charging stage reduces battery gassing, minimizes watering requirements, and ensures the batteries are maintained at optimum capacity.

### 3.5.4 FOURTH STAGE: EQUALIZATION

Equalization charging is used to stir up stratified electrolyte and to reverse any battery plate sulfation that may have occurred. The equalization charging mode can only be used with the PowerTrak™ Display (sold separately).

### 3.5.5 BATTERY CHARGING SET POINTS

SET POINT	GEL	FLOODED	AGM	LITHIUM	CUSTOM
Absorption Voltage	14.1 VDC	14.4 VDC	14.4 VDC	14.4 VDC	13-16 VDC
Float Voltage	13.7 VDC	13.7 VDC	13.7 VDC	14.0 VDC	13-16 VDC
Equalization Voltage		14.9 VDC			

### 3.6 TEMPERATURE COMPENSATION

The Advanced Inverter/Charger is delivered with a battery temperature sensor. When the sensor is installed, the charge voltages are automatically adapted for deviating temperatures between -20°C and 40°C. With a BTS installed, if the temperature of the BTS is below 25 °C, the absorption and float charge voltages increase. If the temperature of the BTS is above 25 °C, the absorption and float charge voltages decrease. The temperature compensation factor is 25 mV/°C by default and can be adjusted on the PowerTrak™ Display (sold separately).

### 3.7 LOAD SENSE

The Advanced Inverter/Charger has a load sensing function that can be enabled/disabled through the PowerTrak™ Display (sold separately). This feature is used to conserve battery power when no AC power is required (no appliances being used). In load sense mode the inverter continually scans the AC output looking for an AC load. When an AC appliance is turned on, an AC load is registered at the AC output and the inverter switches on and supplies power from the battery bank to the appliance. Load sense mode is disabled by default, with a power threshold of 25 W. The PowerTrak™ Display can be used to enable load sense and adjust the power threshold between 5 and 50 W.

## 3.8 AC PASS-THROUGH MODE

In AC pass-through mode, the AC output is supplied by the AC input (utility or generator). The AC input current is limited to the shore breaker size setting, which is set to 30 A by default. This can be adjusted using the PowerTrak™ Display (sold separately). In the example system below, the AC loads require 3600 W, which is provided directly from the AC input. The battery bank is not being charged.

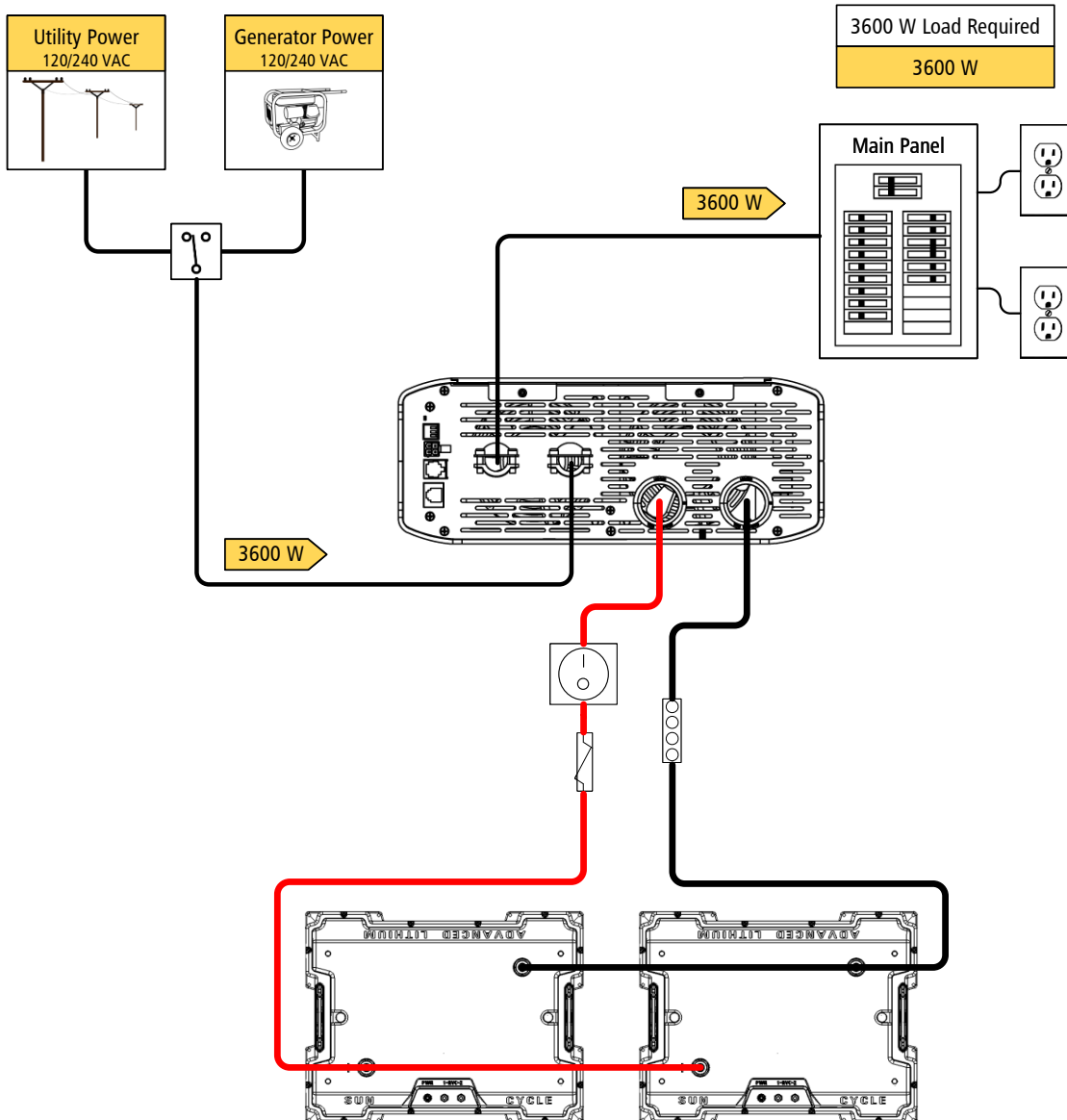

### 3.9 CHARGING MODE

In charging mode, the battery bank is charged from the AC input. The AC input current is limited to the shore breaker size setting, which is set to 30 A by default. This can be adjusted using the PowerTrak™ Display (sold separately). In the example system shown below, the battery bank is being charged with 1800 W, directly from the AC input. There is no AC load present.

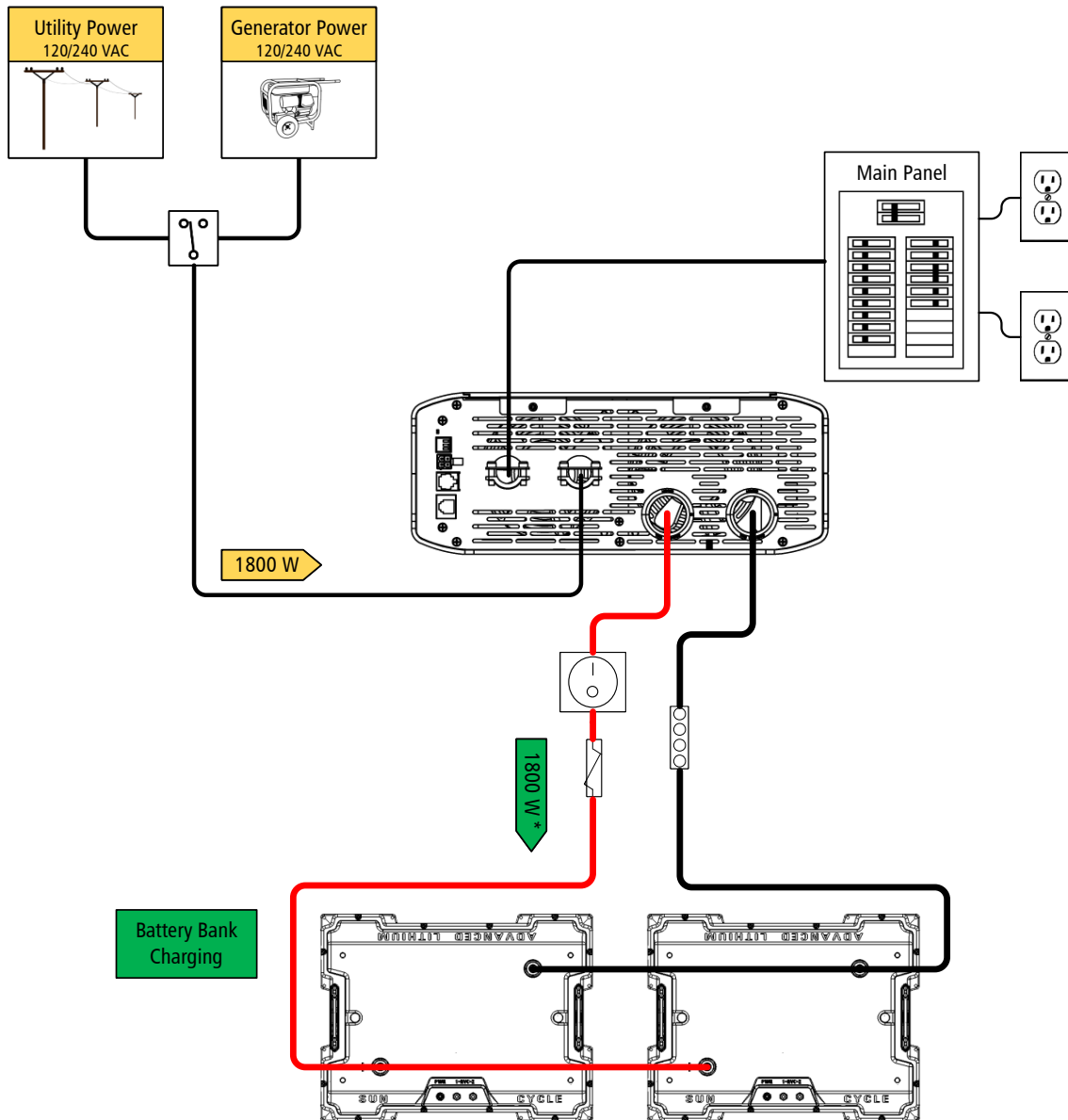

\*Values shown exclude system and efficiency loss

## 3.10 INVERTING MODE

In inverting mode, the AC output is supplied by the battery bank. In the example system shown below, the AC loads require 3000 W, and the inverter is supplying 3000 W from the battery bank. The AC input is not present.

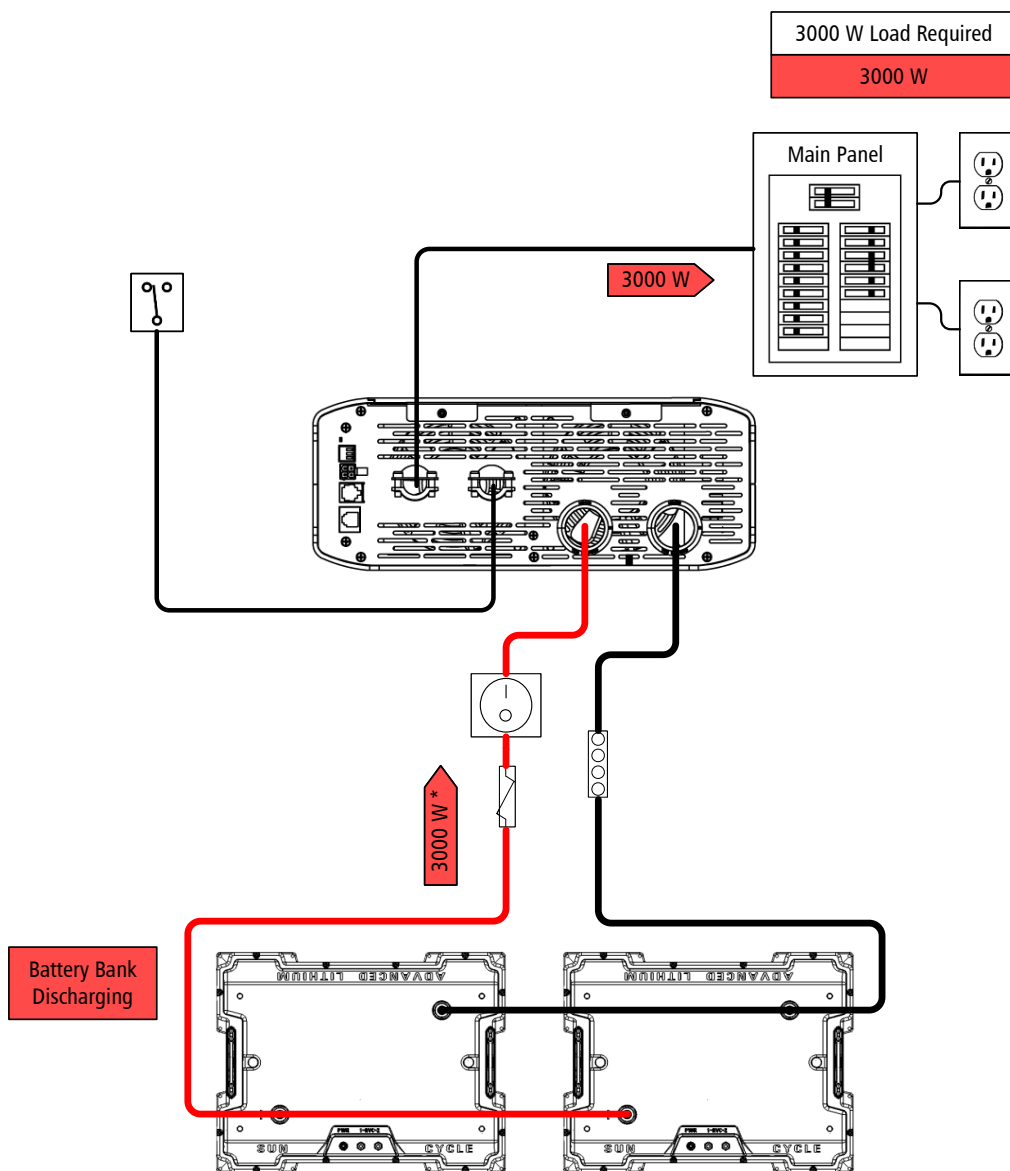

\*Values shown exclude system and efficiency loss

### 3.11 POWER SHARING MODE

In power sharing mode, the AC output is supplied by the AC input and the battery combined. This mode is enabled by default, and requires that both AC input and battery power are available. The AC input current is limited to the shore breaker size setting, which is set to 30 A by default. This PowerTrak™ Display (sold separately) can be used to enable/disable power sharing mode, and to adjust the shore breaker size.

If power sharing is enabled, the AC input is used as the first priority to power the load. If the AC output current demand is lower than the shore breaker size setting, the excess allowed current from AC input is used to charge the battery. If the load demands more current than the shore breaker size setting, then the battery is discharged to provide the remainder of the load demand (power sharing mode).

In the example system below, the AC loads require 1800 W. AC input is connected and supplying 3600 W. 1800 W of AC power is passed through to the AC loads, and the remaining 1800 W is used to charge the battery bank.

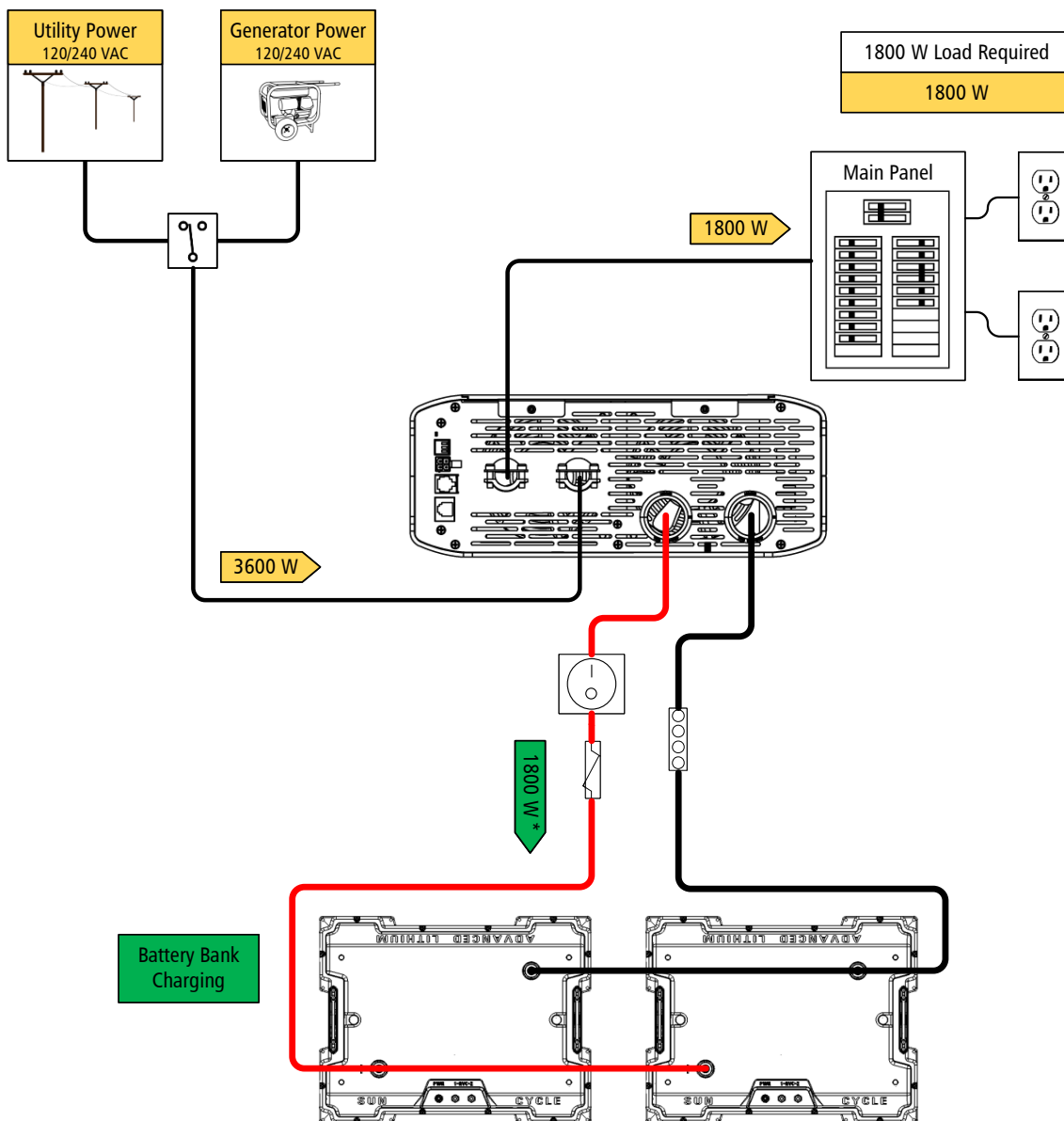

\*Values shown exclude system and efficiency loss

In the example system below, the AC loads require 3600 W. AC input is connected and supplying 2400 W to the AC loads. The inverter automatically switches on and supplies the remaining 1200 W of AC power.

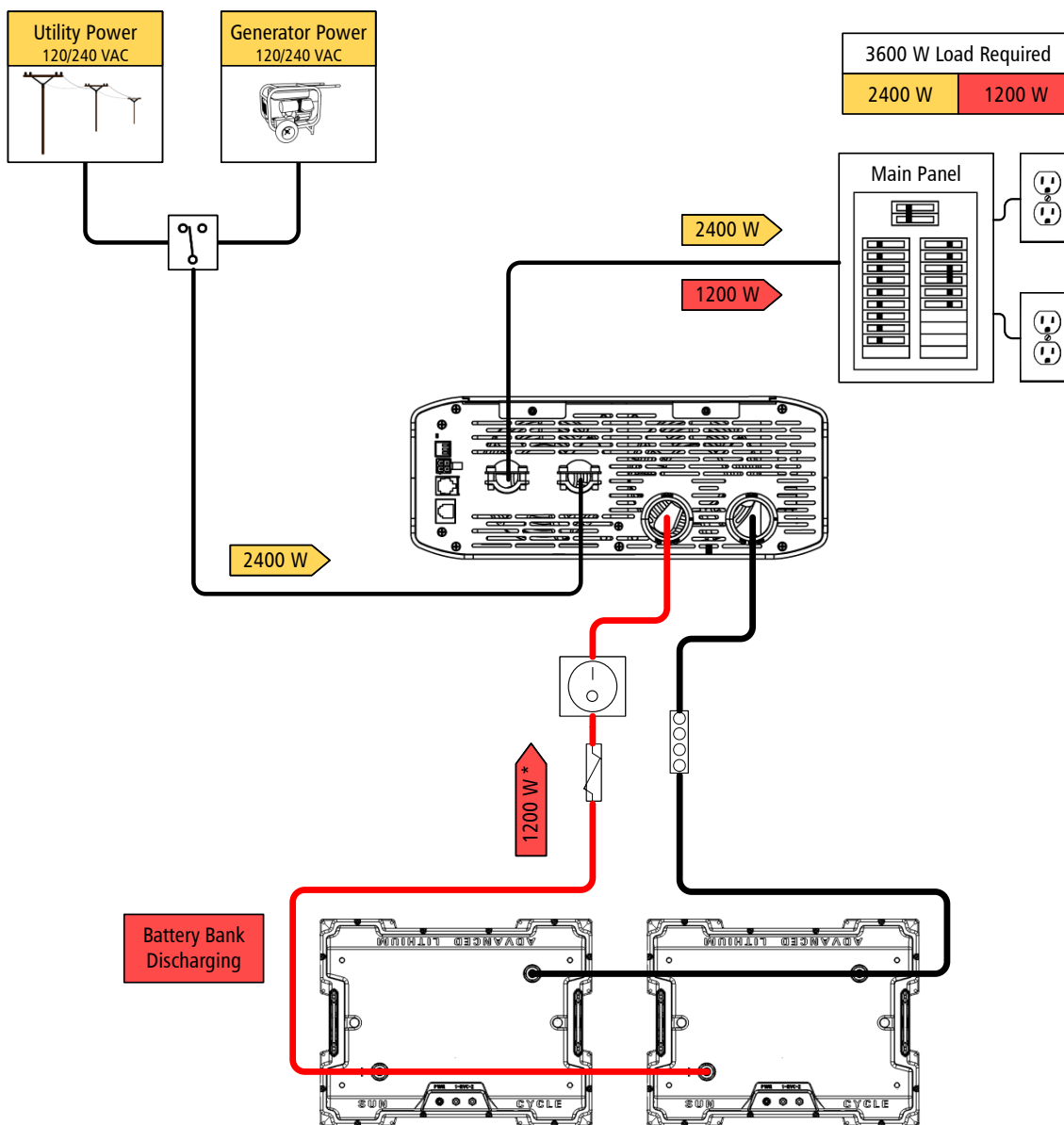

\*Values shown exclude system and efficiency loss



### 3.12 STATUS PARAMETERS

The following parameters are reported over the RV-C network, and can be monitored using the PowerTrak™ Display (sold separately).

<b>PARAMETER</b>	<b>DESCRIPTION</b>
Inverter Status	Real-time inverter state (disabled, inverting, AC pass-through, load sense).
Charger Status	Real-time charging state(charging, not charging).
AC Pass-through Status	Displays if the inverter is enabled and AC input is powering the inverter loads.
Charging From AC Input Status	Displays if AC input is detected and charging the battery bank.
DC Voltage	DC voltage measured from the Inverter/Charger DC terminals.
DC Amps	DC current measured from the Inverter/Charger.
Input AC Voltage	AC voltage measured from the Inverter/Charger AC input.
Input AC Amps	AC current measured from the Inverter/Charger AC input.
Input AC Frequency	AC frequency measured from the Inverter/Charger AC input.
Output AC Voltage	AC voltage measured from the Inverter/Charger AC output.
Output AC Amps	AC current measured from the Inverter/Charger AC output.
Output AC Power	AC power measured from the Inverter/Charger AC output.
Output AC Frequency	AC frequency measured from the Inverter/Charger AC output.
Transformer Temperature	Temperature of the Inverter/Charger's transformer.
FET Temperature	Temperature of the Inverter/Charger's FET.
Battery Temperature	Temperature of the battery temperature sensor (BTS).
Firmware	Firmware version of the Inverter/Charger.
Fault Code	Fault/warning condition reported from the Inverter/Charger. See section 3.15.1 for common fault/warning conditions and recommended troubleshooting steps.

3.13 CONFIGURABLE SETTINGS

The following settings can be configured using the PowerTrak™ Display (sold separately).

3.13.1 INVERTER SETTINGS

PARAMETER	DESCRIPTION	VALUE RANGE		
		AIC-2000-12-SL	AIC-3000-12-SL	AIC-3000-12-DL
Inverter	Turns the inverter on or off.	On/Off		
Load Sense	Allows the inverter to detect and respond to load presence.	On/Off		
Load Sense Interval	Time interval for checking if a load is present.	1 - 25 seconds		
Load Sense Power Threshold	Minimum power level required to activate the inverter in load sense.	5 - 50 W		
DC Min Shutdown Volt	<p>Minimum DC voltage at which the inverter shuts down.</p> <p>If the DC voltage is 1 V above the DC min shutdown voltage, a warning will appear on the PowerTrak™ Display.</p> <p>If the DC voltage reaches the DC min shutdown voltage, the inverter will shut down after the DC shutdown delay (configurable).</p> <p>If the DC voltage is 0.5 V below the DC min shutdown voltage, the device will shut down completely to prevent further discharge from the battery.</p>	10.0 - 12.5 V		
DC Shutdown Delay	Time delay for the inverter shut down after the voltage reaches the DC minimum shutdown voltage.	1 - 300 seconds		
Output AC Volt	The AC voltage level the inverter outputs.	100 V, 110 V, 115 V, 120 V		
Output AC Freq	The frequency of the AC output.	50 Hz, 60 Hz		
Inverter Reset to Default	Restores inverter settings to factory defaults.	-		
Inverter Startup	Begin inverting on startup.	Enable/Disable		
Disable Buzzer	Mutes alarm sounds for faults/warnings.	Enable/Disable		
Shore Breaker Size	Defines the circuit breaker size for shore power input.	10 - 30 A	10 - 50 A	



## 3.13.2 CHARGER SETTINGS

PARAMETER	DESCRIPTION	VALUE RANGE		
		AIC-2000-12-SL	AIC-3000-12-SL	AIC-3000-12-DL
Charger	Turns the charger on or off.	On/Off		
Charger Reset to Default	Restores charger settings to factory default settings.	-		
Battery Type	Defines the type of battery being charged.	Flooded, Gel, AGM, LiFePO4, Custom		
Battery Capacity	Defines the total storage capacity of the battery bank.	0 - 65530 Ah		
Max Charge Current	Defines the maximum charging current.	5 - 100 A	5 - 150 A	
Shore Breaker Size	Defines the circuit breaker size for shore power input.	10 - 30 A		10 - 50 A
Battery Sensor	Displays the battery sensor status.	Active or Not Active		
Charger Startup	Controls the initial state of the charger when the device is powered on.	Enable/Disable		
Absorption Voltage*	Voltage held during the absorption charging stage.	13.0 - 16.0 V		
Absorption Time*	Duration for which the absorption voltage is applied.	0 - 65530 minutes		
Float Voltage*	Maintained voltage to keep the battery fully charged without overcharging.	13.0 - 16.0 V		
Equalization Voltage*	Voltage level used during equalization charging to balance battery cells.	13.0 - 17.0 V		
Equalization Time*	Duration of the equalization charging phase.	0 - 65530 minutes		
Equalization Interval*	Frequency at which equalization charging is performed.	0 - 254 days		

\* Only available when battery type is set to custom. Always refer to the battery manufacturers charging specifications when configuring custom batteries.

## 3.14 FACTORY DEFAULT VALUES

VALUE	AIC-2000-12-SL	AIC-3000-12-SL	AIC-3000-12-DL
Battery Type	AGM		
Battery Capacity	200 Ah		
Absorption Time	120 min		
Equalization Time*	120 min		
Max Charge Current	80 A	120 A	120 A
Low Battery Disconnect/Cut Off	10.5 V		
Low Battery Disconnect Delay	300 s (5 min)		
Low Battery Recovery Voltage	12.5 V		
High Battery Disconnect / Cut Off	16.5 V		
High Battery Recovery Voltage	15.0 V		
Temperature Compensation Coefficient	-25 mV/°C		
AC Input Undervoltage	65 VAC		
AC Input Overvoltage	140 VAC		
AC Input Under Frequency	55 Hz		
AC Input Over Frequency	65 Hz		
Shore Breaker Size	30 A		
Output AC Voltage	120 VAC		
Output AC Frequency	60 Hz		
Output Power Limit	2000 W	3000 W	3000 W
Output Power Limit Delay	300 s (5 min)		
Load Sense Threshold	25 W		
Load Sense Interval	1 s		

\* Only available when battery type is set to custom. Always refer to the battery manufacturers charging specifications when configuring custom batteries.

## 3.15 TROUBLESHOOTING

This section will provide information for diagnosing faults/warnings on the Inverter/Charger. Please review this section, and have a qualified technician work through the applicable troubleshooting steps before contacting technical support.



**WARNING!** The troubleshooting steps outlined in this manual should only be performed by qualified personnel.



**WARNING!** Disconnect AC and DC power before performing troubleshooting tasks related to AC or DC circuits. Under no circumstances should the sliding terminal cover be removed from the Inverter/Charger while it is connected to AC or DC power.

### 3.15.1 COMMON FAULT/WARNING CONDITIONS

If a fault or warning condition occurs, it will be displayed on the PowerTrak™ Display (sold separately). Depending on the fault, the Inverter/Charger may shut down the output to protect itself, the battery bank, and/or the AC loads. The table below outlines common fault and warning conditions.

ITEM	FAULT/WARNING CONDITION	POSSIBLE CAUSE	RECOMMENDED SOLUTION
1	No AC input power.	AC shore power is not connected.	Connect shore power. If shore power is not available, this warning will remain active and can be ignored.
		Break in the AC input circuit.	Check all connections for a break in the AC input circuit: circuit breakers, AC input panel connections, IC terminal connections, wire integrity.
2	Battery undervoltage warning.	Battery voltage is below low voltage.	Recharge the batteries above the discharge voltage. Ensure shore power is connected and the charger is enabled.
		Load too high for battery state of charge.	If shore power is not available, consider disabling the inverter and allowing the batteries to charge off solar without any AC loads.
3	Battery open circuit.	Batteries disconnected.	Connect the batteries.
		Break in the DC circuit.	Check all connections for a break in the DC circuit between the IC and the battery bank: circuit breakers, fuses, DC disconnect switch, terminal connections, wire integrity.
4	No AC input power detected on line 2. (AIC-3000-12-DL only)	AC shore power is not connected to line 2.	Connect shore power to line 2. If shore power is not available, or line 2 is intentionally not connected to shore power, this warning will remain active and can be ignored.
		Break in the AC input circuit.	Check all connections for a break in the AC input circuit: circuit breakers, AC input panel connections, IC terminal connections, wire integrity.
5	IC fan fault.	Debris caught in the fan.	Visibly inspect fans for debris. Remove debris if possible.
6	AC output overload.  Note: If this fault is triggered >3 times, the IC will not recover on its own. It must be power cycled using the on/off switch. In this state, attempting to reset the IC with the PowerTrak™ Display will cause the device to power off, and it will need to be manually powered on with the on/off switch.	AC output power exceeds the maximum continuous power/surge power rating.	Shut off any excess loads. The IC should recover after approximately 30 seconds.

7	IC overheat warning.  Note: If this fault is triggered, the IC will not recover on its own. It must be power cycled using the on/off switch. In this state, attempting to reset the IC with the PowerTrak™ Display will cause the device to power off, and it will need to be manually powered on with the on/off switch.	Insufficient space around the IC.	Ensure the IC has been installed according to the ventilation requirements in section 2.2.3 of this manual.
		High ambient temperature combined with the IC operating at the maximum continuous power rating for an extended period of time.	Reduce AC loads and allow the IC to cool down.
8	Short circuit on AC output.  Note: If this fault is triggered, the IC will not recover on its own. It must be power cycled using the on/off switch. In this state, attempting to reset the IC with the PowerTrak™ Display will cause the device to power off, and it will need to be manually powered on with the on/off switch.	Short circuit on AC output.	Disconnect the cables from the AC output terminals on the IC. Power on the IC and check if the fault message is still active. If the fault is not active, there is a short circuit in the AC output wiring which must be resolved before reconnecting the IC. If the fault is still active, contact the dealer.
9	Battery overvoltage fault.	Overcharging from the IC or an external charger.	Disconnect any external chargers. Check charge settings on all charging sources. Run the inverter without shore power to decrease the battery voltage.
10	Battery undervoltage fault.	Battery voltage is below low voltage. Load on battery too high for state of charge.	Recharge the batteries above the discharge voltage. Ensure shore power is connected and the charger is enabled. If shore power is not available, consider disabling the inverter and allowing the batteries to charge off solar without any AC loads. If the battery voltage drops too low, the unit will shut itself off.
11	AC output overcurrent.  Note: If this fault is triggered >3 times, the IC will not recover on its own. It must be power cycled using the on/off switch. In this state, attempting to reset the IC with the PowerTrak™ Display will cause the device to power off, and it will need to be manually powered on with the on/off switch.	AC output current too high.	Shut off any excess loads. The IC should recover after approximately 30 seconds.

## 3.15.2 TROUBLESHOOTING GUIDE

SYMPTOM	POSSIBLE CAUSE	RECOMMENDED SOLUTION
No output power Status LED is red	Short circuit on AC output.	Refer to item 8 in the fault/warning condition table in section 3.15.1.
	AC output overload.	Refer to item 6 in the fault/warning condition table in section 3.15.1.
	AC output overcurrent.	Refer to item 11 in the fault/warning condition table in section 3.15.1.
	IC overheat warning.	Refer to item 7 in the fault/warning condition table in section 3.15.1.
	Battery undervoltage.	Refer to item 2 in the fault/warning condition table in section 3.15.1.
	Internal fault.	Power cycle the device using the on/off switch.
No output power Status LED is off	Device is off.	Turn the device on using the main on/off switch.
	Device shut down due to low battery voltage.	Refer to item 2 in the fault/warning condition table in section 3.15.1.
	Device shut down due to repeated overloads.	Power cycle the device using the on/off switch.
No output power Status LED is blue or white	The AC output is disabled.	Ensure the inverter setting is enabled on the PowerTrak™ Display.
	The main on/off switch is off.	Turn the device on using the main on/off switch.
No output power/Pulsing output power Status LED is green	The device has load sense mode enabled, but the load sense power threshold has not been met to turn the device on.	Review the load sense power threshold settings on the PowerTrak™ Display and adjust if necessary, or disable load sense mode.
No charge Status LED is green or white	Charger is disabled.	Enable the charger on the PowerTrak™ Display to begin charging.
No charge Status LED is blue or blue/green	Battery is fully charged or above the charging voltage.	Charging will resume when the voltage reaches to the recharge voltage. Refer to the battery charger specifications in section 3.5 for more details.
	No AC input power.	Refer to item 1 in the fault/warning condition table in section 3.15.1.
	AC input/shore breaker has tripped.	Review the shore breaker settings on the PowerTrak™ Display and adjust if necessary. Make sure the shore breaker size setting does not exceed the shore breaker being used. Reset the shore breaker.
	The device is in power sharing mode and the AC load meets or exceeds the shore breaker limit.	Shut off any excess AC loads to allow the battery to charge from the AC input.
	The quality of the AC input power does not meet the requirements.	Review the AC input requirements in the specification table in section 4.
	Battery open circuit/no connection to the battery.	Refer to item 3 in the fault/warning condition table in section 3.15.1.
No charge Status LED is red	Battery overvoltage.	Refer to item 9 in the fault/warning condition table in section 3.15.1.

Low charge rate	Shore breaker size is limiting the charge rate.	Review the shore breaker size setting on the PowerTrak™ Display and adjust if necessary. Make sure the shore breaker size setting does not exceed the shore breaker being used.
	Maximum charge current setting is limiting the charge rate.	Review the maximum charge current setting on the PowerTrak™ Display and adjust if necessary. Always follow the charging specifications recommended by the battery manufacturer.
	The device is in power sharing mode and the AC input power is being shared between the AC load and charging the battery.	Shut off any excess AC loads to allow the battery to charge at a higher rate from the AC input.

### 3.16 MAINTENANCE

The Advanced Inverter/Charger is designed to be service-free. Even though there are no user serviceable parts, it is recommended that every 6 months you perform the following maintenance steps to ensure optimum performance and extend the life of your batteries:

- Visually inspect the batteries for cracks, leaks, or swelling—replace if necessary.
- Use baking soda to clean and remove any electrolyte spills or buildup.
- Check and tighten all battery terminal connections.
- Check and fill battery water levels in flooded lead acid batteries.
- Check individual battery voltages (load test those that have a voltage difference of more than 0.3 VDC from each other) and replace if necessary.
- Check the Inverter/Charger's ventilation vents—clean if necessary.
- Visually inspect all cables in both the DC and AC systems. Check for wear/abrasion. Replace if necessary and ensure strain reliefs and cable protection is installed to prevent future damage.
- Check and tighten all connections on inside of the Inverter/Charger's sliding terminal cover.
- Check the ground connections are secure on the Inverter/Charger, battery bank, main/sub panels and the earth ground on the RV, or boat.
- Check the battery temperature sensor is still securely attached to the battery bank, if applicable.

## 4. SPECIFICATIONS



PARAMETER		AIC-2000-12-SL	AIC-3000-12-SL	AIC-3000-12-DL
AC Pass-through Mode	Input Voltage Waveform	Sinusoidal (utility or generator)		
	Nominal Input Voltage	120 VAC		
	AC Input Voltage Range	65-140 VAC		
	Nominal Input Frequency	60 Hz		
	Input Frequency Range	55-65 Hz		
	Transfer Time	< 20 ms		
	Max AC Input Current	30 A	30 A	50 A
Inverter Mode	Nominal DC Voltage	12 VDC		
	HBCO/HBCI	16.5/15 VDC		
	LBCO/LBCI	10.5/12.5 VDC (programmable)		
	Max DC Input Voltage	17 VDC		
	THDV	< 3% @ Nominal Voltage		
	Continuous Power	2000 W	3000 W	
	Surge Power (200 ms)	4000 W	6000 W	
	Surge Power (5 s)	3400 W	4800 W	
	Surge Power (5 min)	2900 W	3300 W	
	Output Frequency	60 Hz (programmable)		
	Output Voltage	120 VAC (programmable)		
	Output Waveform	Pure Sine Wave		
	Peak Efficiency	> 85%		
	No Load Power Consumption	< 25 W @ 12.5 VDC		
	Stand-By Power Consumption (Inverter Disabled)	< 15 W @ 12.5 VDC		
Hibernation Mode Consumption	< 2 W @ 12.5 VDC			
Charger Mode	Max Charging Current	100 A	150 A	
	Multi-stage Charging	Bulk, Absorption, Float, Equalize		
	Temperature Compensation	External battery sensor: -25 mV/°C		
	Power Factor Correction	> 0.98 (1 C)	< 0.95 (1 C)	
RV-C Network Power Supply	Nominal Voltage	15 VDC		
	Max Current	250 mA		



		<b>AIC-2000-12-SL</b>	<b>AIC-3000-12-SL</b>	<b>AIC-3000-12-DL</b>
Environmental	Operating Temperature (without derating)	-20 °C to 40 °C		
	Operating Temperature (with derating)	-20 °C to 60 °C		
	Relative Humidity	5% to 95% non-condensing		
	Storage Temperature	-20 °C to 60 °C		
	Certifications & Compliance	FCC Class B Part 15, Industry Canada ICES-003 Class B, UL 458, CSA 107.1, ABYC A31, ABYC E11		
Mechanical	Dimensions (L x W x H)	19.7 x 11.3 x 4.4 in (499 x 288 x 112 mm)		
	Net Weight	20.6 lbs (9.34 kg)	21.1 lbs (9.57 kg)	21.7 lbs (9.84 kg)
Warranty		3 years		

## 5. WARRANTY RETURN PROCEDURE

The Go Power! | Dometic warranty is valid against defects in materials and workmanship for the specific product warranty period. It is not valid against defects resulting from, but not limited to:

- Misuse and/or abuse, neglect, or accident.
- Exceeding the unit's design limits.
- Improper installation, including, but not limited to, improper environmental protection and improper hook-up.
- Acts of God, including lightning, floods, earthquakes, fire, and high winds.
- Damage in handling, including damage encountered during shipment.

A warranty shall be considered void if the warranted product is in any way opened or altered. The warranty will be void if any fasteners used to seal the unit are removed or altered, or if the unit's serial number is in any way removed, altered, replaced, defaced, or rendered illegible.

### Warranty Return Procedure

Before contacting the customer service department, please read the "frequently asked questions" section of our website to troubleshoot the problem. If trouble persists:

Call the Technical Support team (1-866-247-6527) or return defective product to place of purchase.

Unless approved by Go Power! | Dometic Management, all product shipped collect to Go Power! | Dometic will be refused. Test items or items that are not under warranty, or units that are not defective, will be charged a minimum bench charge of \$50.00 US plus taxes and shipping. A 15% restocking charge will be applied on goods returned and accepted as "new" stock.

An RMA (return materials authorization) number from Go Power! | Dometic Customer Service is required prior to returning any Go Power! | Dometic products. Go Power! | Dometic reserves the right to refuse any items sent to Go Power! | Dometic without an associated RMA number. To obtain an RMA number, please contact [customersupport.gopower@dometic.com](mailto:customersupport.gopower@dometic.com) or Telephone 1-866-247-6527.

### Out of Warranty

Go Power! | Dometic electronic products are non-repairable. Go Power! | Dometic does not perform repairs on its products nor does it contract out those repairs to a third party. Go Power! | Dometic does not supply schematics or replacement parts for any of its electronic products.

### Product E.O.L (end of life) Information

This product required the extraction and use of natural resources. It may contain substances that could be harmful to the environment or human health if improperly handled at the product's end of life. In order to avoid release of such substances into the environment and to reduce the use of natural resources, we encourage you to recycle the Inverter/Charger in an appropriate way that will ensure most of the materials are reused or recycled appropriately.

## 6. END OF LIFE - RECYCLING INFORMATION

### DO NOT DISPOSE OF THIS PRODUCT WITH NORMAL GARBAGE.



The easiest way to recycle an Inverter/Charger is to take the unit to a local certified e-waste (electronics waste) recycling center. Knowing for sure if your appliances are being recycled properly is tricky. If you're in doubt just ask. Recyclers that are certified should gladly show you their certification. If the recycler is certified, chances are very high that they are recycling responsibly.

To find your local e-waste center please contact your local municipality. The following website also has information on local recycling centers: [www.earth911.com/recycling-center-search-guides](http://www.earth911.com/recycling-center-search-guides)

