



599 SERIES
Infrared SMD LED
0603 Package Top View 940nm
With Dome Lens

MECHANICAL / SPECIFICATIONS

PART NUMBER:
[599-17C0-147IRF](#)

DIMENSIONS:
1.6 x 0.8 x 0.95mm

LENS COLOR:
Clear

LENS MATERIAL:
Epoxy

STANDARD PACKAGING:
4000/reel

MOISTURE SENSITIVITY LEVEL:
2a

CERTIFICATIONS & RATINGS
RoHS Compliant

RECOMMENDED PAD LAYOUT

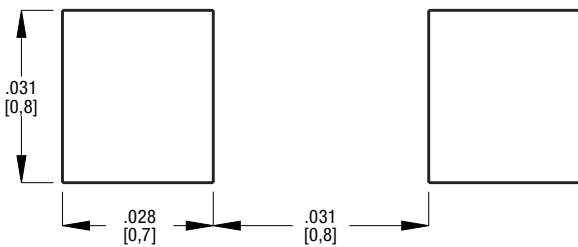

LED SCHEMATIC



DIMENSIONS inches [mm]

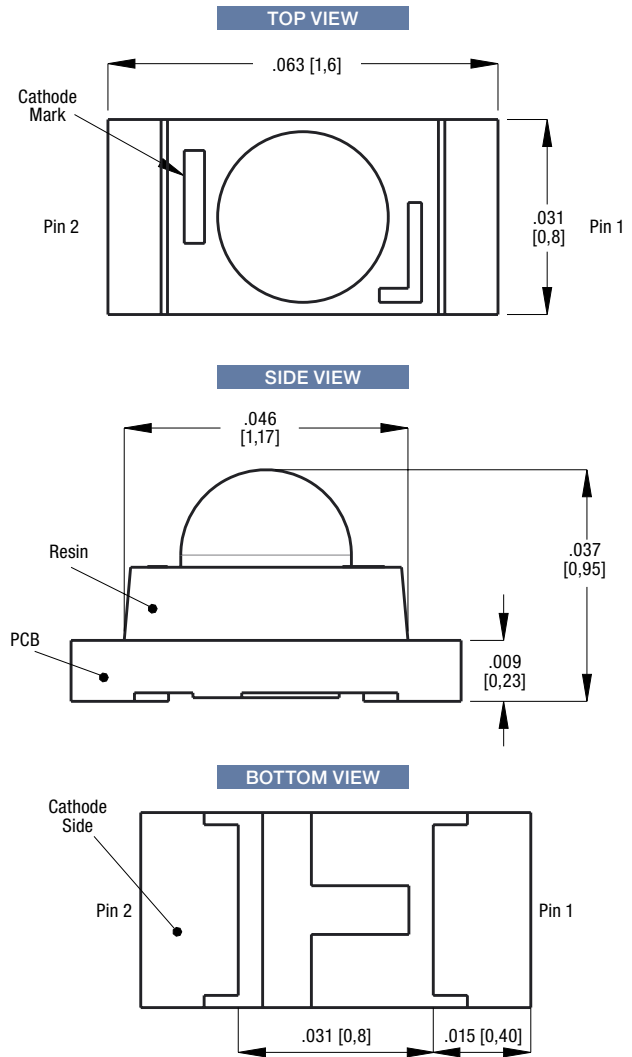

ABSOLUTE MAXIMUM RATINGS AT 25°C

Symbol	Parameter	Ratings	Units	Notes
I_F	Forward Current	50	mA	
I_{FP}	Peak Current	500	mA	1
V_R	Reverse Voltage	5	V	
T_{opr}	Operating Temperature	-40~+85	°C	
T_{stg}	Storage Temperature	-40~+100	°C	
T_{sol}	Soldering Temperature	260	°C	2

Notes:

1. IFP Conditions — Pulse Width $\leq 100\mu s$ and Duty $\leq 1\%$.
2. Soldering time ≤ 5 seconds.

ELECTRICAL - OPTICAL CHARACTERISTICS

Symbol	Parameters	Test Conditions	Min	Typ	Max	Unit
I_e	Radiant Intensity	$I_F=20mA$	4.0	-	11.5	mW/sr
λ_p	Peak Wavelength	$I_F=20mA$	-	940	-	nm
$\Delta\lambda$	Spectral bandwidth	$I_F=20mA$		33	-	nm
V_F	Forward Voltage	$I_F=20mA$	1.2	-	1.8	V
I_R	Reverse Current	$V_R=5V$	-	-	10	μA
$2\theta_{1/2}$	Angle of Half Intensity	$I_F=20mA$	-	60	-	deg

TYPICAL ELECTRICAL-OPTICAL CHARACTERISTICS

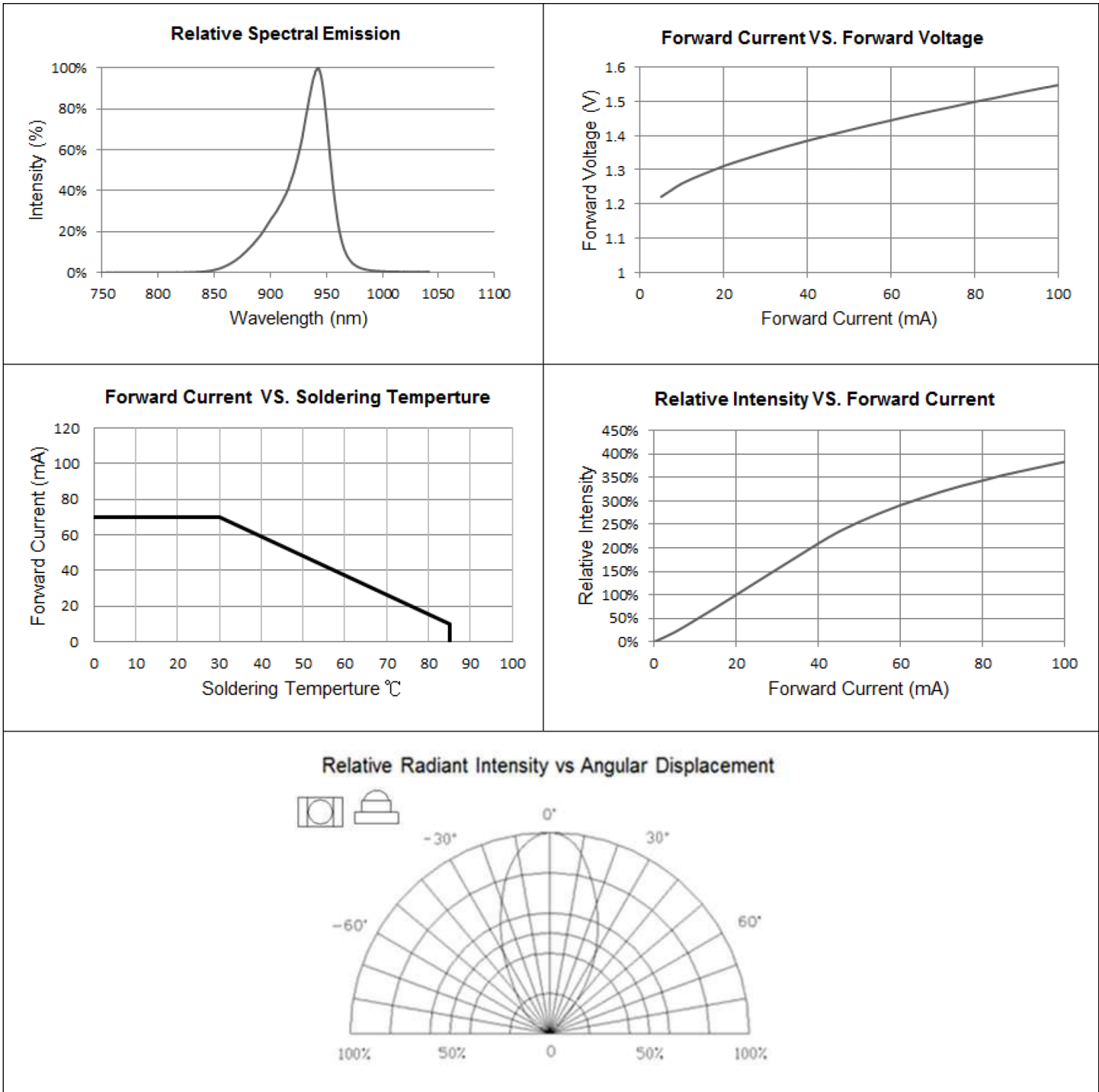

TAPE AND REEL SPECIFICATION

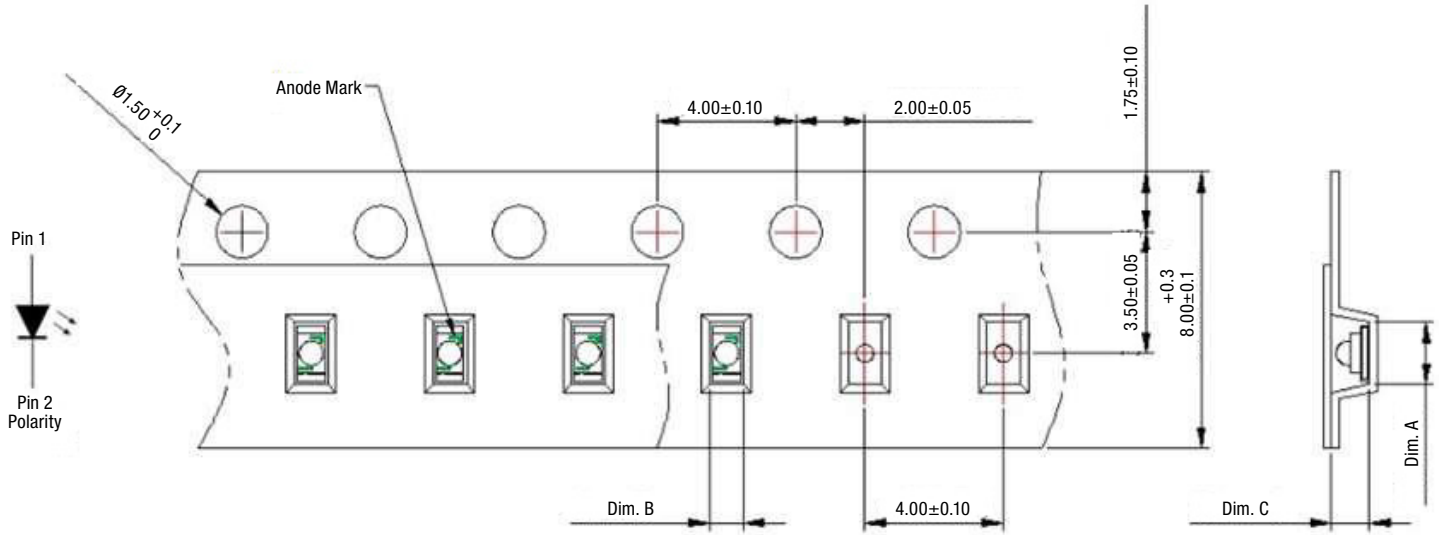

Dim A	Dim B	Dim C	Quantity/Reel
1.85±0.05	0.88±0.05	0.95±0.05	4K

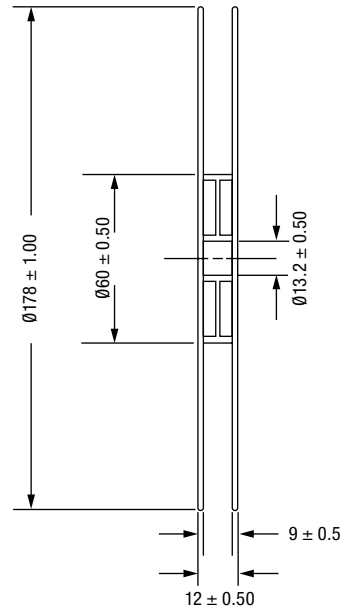
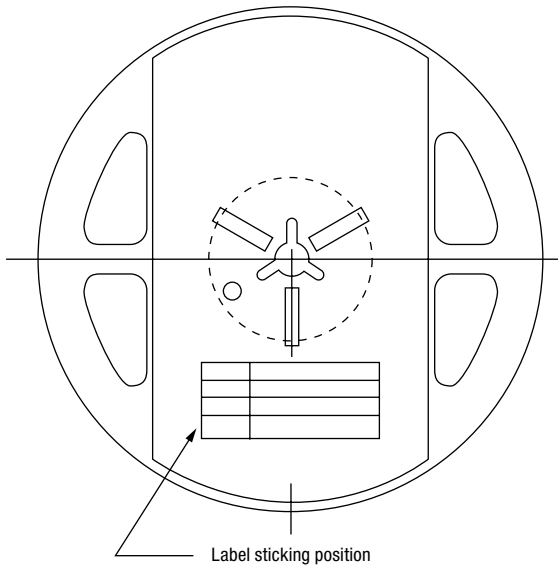

Unit: mm

REFLOW SOLDERING

Recommended soldering paste specifications:

- 1. Operating temp.: Above 217°C, 60~150sec.
- 2. Peak temp.: 260°C Max., 10sec Max.
- 3. Reflow soldering should not be done more than two times.

LEAD-FREE SOLDER PROFILE

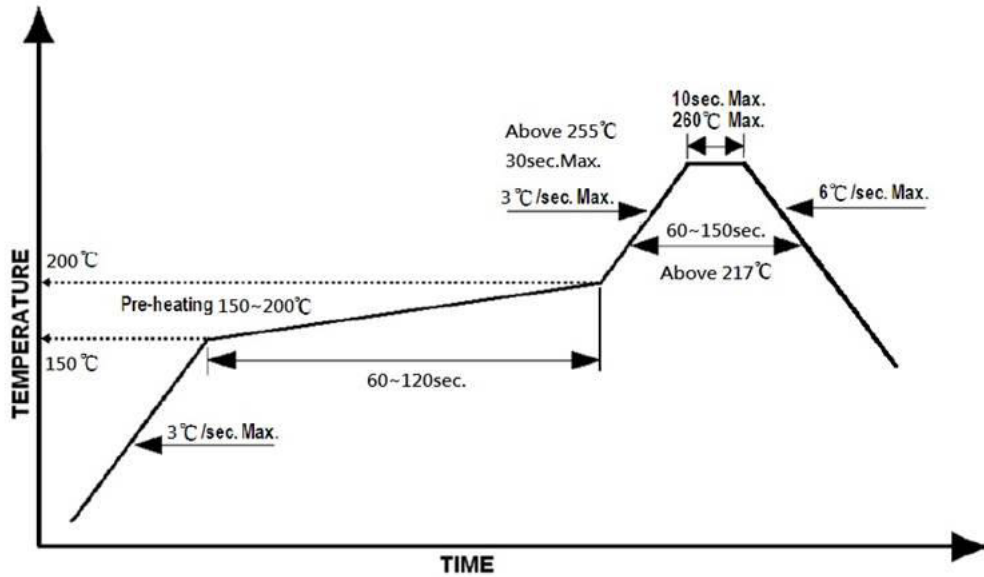

Dialight reserves the right to make changes at any time in order to supply the best product possible. The most current version of this document will always be available at: www.dialightsignalsandcomponents.com

Warranty Statement: Except for the warranty expressly provided for at: www.dialight.com/resources/warranties/, Dialight disclaims any and all other warranties, express or implied, including, without limitation, any warranties of merchantability, fitness for a particular purpose, title, and noninfringement.