

NOTES:

- 1. MATERIALS AND FINISHES:  
 MMCX RA PLUG - BRASS, GOLD PLATING  
 N STR BHD JACK - BRASS, NICKEL PLATING  
 CABLE - RG 174
- 2. ELECTRICAL:  
 A. IMPEDANCE: 50 OHM
- 3. PACKAGING:  
 A. QUANTITY: SINGLE PACK  
 B. MARKING: BAG TO BE MARKED  
 "AMPHENOL RF, 95-900-646-XXX AND DATE CODE"

REVISIONS				
REV	DESCRIPTION	DATE	ECN	BY
A	RELEASE TO MFG.	29-JUN-26	17949	AMP

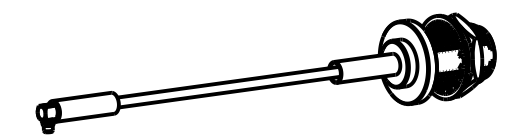

SCALE 0.500

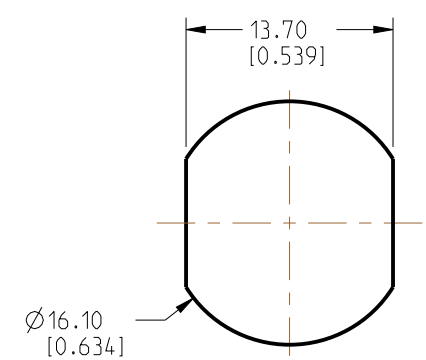

**RECOMMENDED MOUNTING HOLE DIMENSIONS**

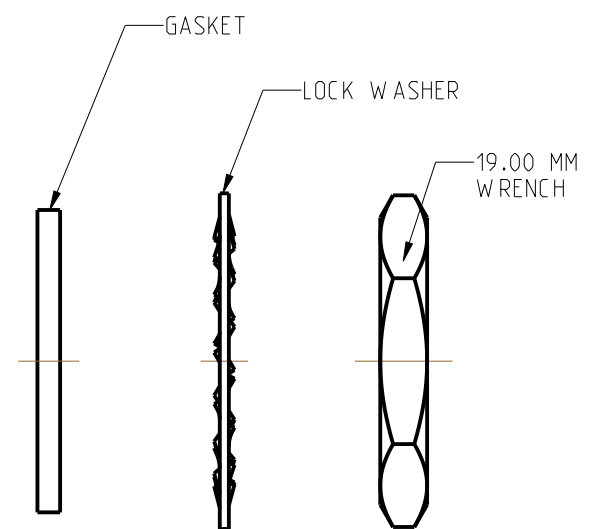
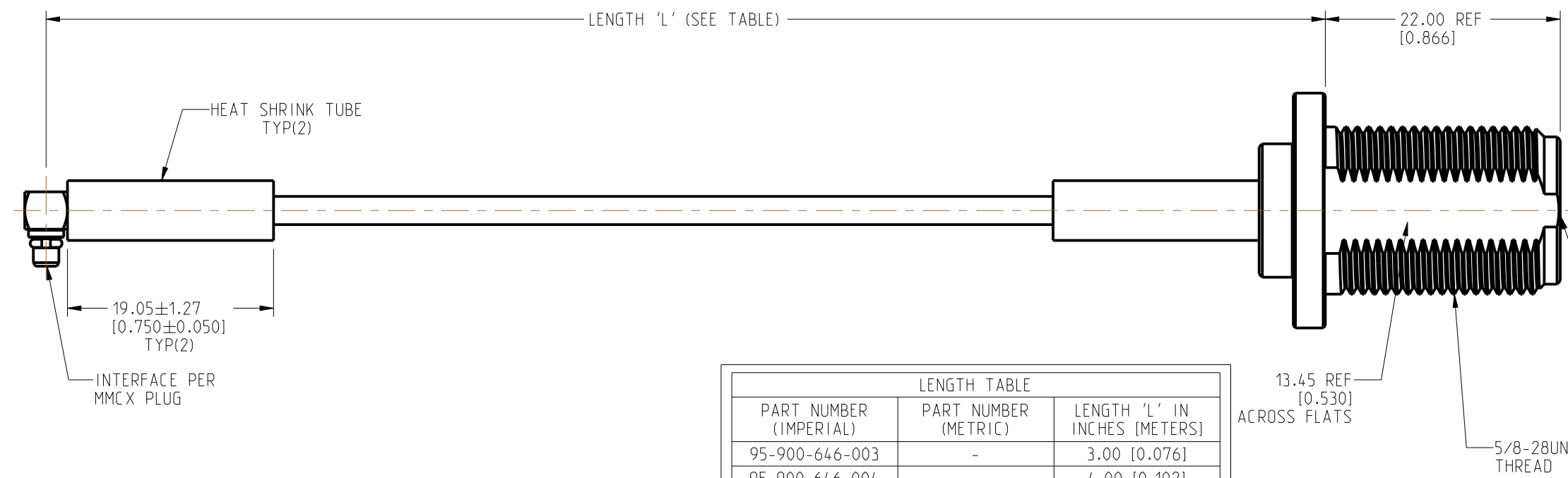

LENGTH TABLE		
PART NUMBER (IMPERIAL)	PART NUMBER (METRIC)	LENGTH 'L' IN INCHES (METERS)
95-900-646-003	-	3.00 [0.076]
95-900-646-004	-	4.00 [0.102]
95-900-646-005	-	5.00 [0.127]
95-900-646-006	-	6.00 [0.152]
95-900-646-007	-	7.00 [0.178]
95-900-646-008	-	8.00 [0.203]
95-900-646-009	-	9.00 [0.229]
95-900-646-010	-	10.00 [0.254]
95-900-646-011	-	11.00 [0.279]
95-900-646-012	-	12.00 [0.305]
95-900-646-018	-	18.00 [0.457]
95-900-646-024	-	24.00 [0.610]
95-900-646-036	-	36.00 [0.914]
-	95-900-646M100	39.37 [1.000]
95-900-646-048	-	48.00 [1.219]

TOLERANCE TABLE	
LENGTH IN INCHES/FT [METERS]	TOLERANCE
0" - 23.99" [0 - 0.609]	±0.25" [0.006]
24.00" - 59.99" [0.610 - 1.523]	±0.50" [0.013]
5.0' - 24.99' [1.524 - 7.617]	±2.5%
25.0' & UP [7.620 & UP]	±5.0%

**DESIGN REQUIREMENTS:**

<input checked="" type="checkbox"/> FREQUENCY: DC - 3 GHz	<input checked="" type="checkbox"/> CONTINUITY
<input type="checkbox"/> VSWR: _____ 1 MAX.	<input checked="" type="checkbox"/> HI-POT: 300 VRMS
<input type="checkbox"/> INS. LOSS: _____ dB MAX.	<input type="checkbox"/> OTHER

**CUSTOMER OUTLINE DRAWING**  
 ALL OTHER SHEETS ARE FOR INTERNAL USE ONLY

NOTICE: These drawings, specifications, or other data (1) are, and remain the property of Amphenol corp. (2) must be returned upon request; and (3) are confidential and not to be disclosed to any person other than those to whom they are given by Amphenol Corp. The furnishing of these drawings, specifications, or other data by Amphenol Corp., or to any other person to anyone for any purpose is not to be regarded by implication or otherwise in any manner licensing, granting rights to permitting such holder or any other person to manufacture, use or sell any product, process or design, patented or otherwise, that may in any way be related to or disclosed by said drawings, specifications, or other data.		UNLESS OTHERWISE SPECIFIED DIMENSIONS ARE METRIC [INCHES] AND TOLERANCES ARE: <0.5mm = ±0.05mm [ $\pm 0.020 = \pm 0.002$ ] 0.5 - 6mm = ±0.1mm [ $\pm 0.020 - 0.236 = \pm 0.004$ ] >6.00 - 30mm = ±0.2mm [ $\pm 0.236 - 1.181 = \pm 0.008$ ] >30.00 - 120mm = ±0.3mm [ $\pm 1.181 - 4.725 = \pm 0.012$ ] ANGLES = ±1°		MATERIAL SEE NOTES		TITLE MMCX RA PLUG TO N STR BHD JACK USING RG 174 CABLE		<b>Amphenol RF</b>	
THIRD ANGLE PROJ.  REFERENCE		ENGR.1 PONNARASAN		ENGR.2		DATE 14-OCT-25		SHEET NO. 2 OF 2    SCALE: 2.0:1.0	
EAR# 13263						DRAWING NO. 95-900-646-XXX ITEM NO. 95-900-646-XXX PART NO. 95-900-646-XXX		REV A	