

Elma Bustronic CompactPCI Reference Sheet

CompactPCI Reference Sheet

The cPCI reference sheet provides relevant reference material for the CompactPCI product line. The information provided may change at anytime. Elma Bustronic does not assume responsibility for the accuracy of the content provided within.

STRIPLINE DESIGN

The stripline design reduces crosstalk by shielding the signal lines with the power layers above and below. Our standard design features 2 oz. copper outer ground planes that fully shield the backplane and minimize EMI/RFI emissions susceptibility, minimize crosstalk, and maximize power distribution. In addition, the robust outer ground layers provide mechanical protection for the backplane. Measured results show that Elma Bustronic backplanes are among the quietest in the industry.

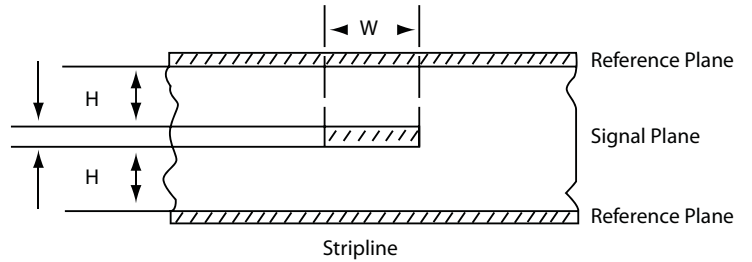

PRESSFIT RECOMMENDATIONS

AMP*

The following AMP and ERNI connector information is in reference to the 2 mm hard metric connectors specified on CompactPCI backplanes. Details of the PCB hole size and finish apply to all Action Pin contacts. IEC61076-4-101 specifies the position of holes to within 0.1 mm [.004]. For feedthrough posts, AMP recommends true position within 0.05 mm [.002] to minimize out-of-position post tips. If repair or replacement is necessary, a new contact can be inserted into the same hole three times without damage.

*AMP catalog 1307515, issued 9-99

ERNI**

The ERNI pressfit recommendations apply to the 2 mm hard metric connectors specified on CompactPCI backplanes.

All Ermet 5+2 row and 8+2 row signal contacts are pressfit. In addition, the bladed Ermet power connectors are also pressfit and share the same board plated hole requirements as the male and female signal connectors. The Ermet 2 mm H.M. Connectors have been used successfully with reflowed tin-lead, plated tin-lead, immersion tin, organic coatings over bare copper, and immersion gold hole plating regimes.

**ERNI catalog MCER41, issued 8-99

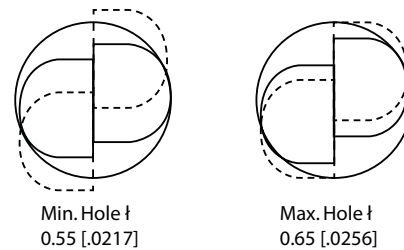

Two spring members compress to different degrees to accommodate hole tolerances.

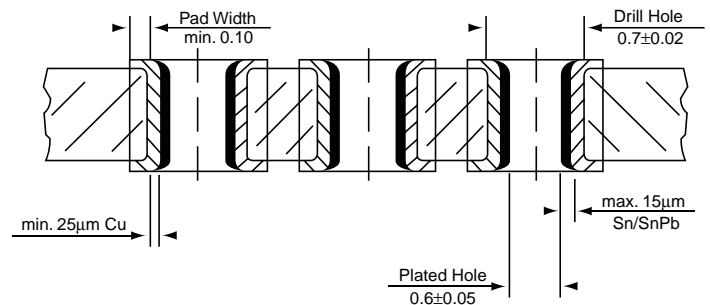

CompactPCI Reference Sheet

GENERAL CONNECTOR SPECIFICATIONS-CPCI

2mm Hard Metric Connector

Connector Pitch:	2.0mm
Temperature Range:	-55° C to 125° C
Mating Cycle per:	61076-4-101 level 3 → 50 mating cycles 61076-4-101 level 2 → 250 mating cycles 61076-4-101 level 1 → 500 mating cycles
Contact Normal Force:	.8 Newtons/contact
Mating Force per IEC 512-7, Test 13a:	Contact-n x .75 Newtons max. (n=# of contacts) Ground Pin to Shield-n x 1 Newtons max. (n=# of contacts)
Insertion/Withdrawl Force per Contact IEC 512-7, Test 13a:	Contact-.15 Newtons min. Ground Pin to Shield-.15 Newtons min. Contact Insertion Force per Pin IEC 352-5 Paragraph 3.2.2.2: 36.3 Newtons Average
Flammability:	UL 94V-0
Contact Resistance per IEC 512, Test 2a:	20 mΩ max.

OTHER CONNECTORS

IPMB Connector (SMT)

Number of Positions:	5
Number of Rows:	1
Operating Temperature:	85.0 °C (max)
Contact Material:	Phosphor Bronze
Flammability Rating:	UL 94 V-0
Gender:	Male
Housing Color:	Natural
Lead-Free Status:	Lead Free
Mounting Type:	Surface Mount
Packaging:	Tape
RoHS:	Compliant
Termination Style:	Solder Tab
Overall length:	0.615 inches minimum and 0.635 inches maximum



CompactPCI Reference Sheet

OTHER CONNECTORS

ATX Connector (20 pins)

Voltage:	600 A
Current (used with 16 AWG):	9A per contact
Contact Insertion Force:	15kg max.
Contact Retention to Housing:	3.0kg min
Contact Resistance:	10 mΩ max.
Dielectric Strength:	1500V A
Insulation Resistance:	1000 MegaΩ min.
Normal Force:	200g min.
Temperature:	-40° C to + 105° C

Pin	Signal	Signal	Pin
1	+3.3V	+3.3V	11
2	+3.3V	-12V	12
3	GND	GND	13
4	+5V	PS-ON	14
5	GND	GND	15
6	+5V	GND	16
7	GND	GND	17
8	PWROK	-5V	18
9	5VSTBY	+5V	19
10	+12V	+5V	20

Utility Connector (14 pins)

Current:	1 A per pin
Insulation Resistance:	>1 x 10 ⁹ Ω @ 500V DC
Dielectric Strength:	1000 VRMS @ Sea Level
Temperature:	-55° C to + 125° C

Pin	Signal	Signal	Pin
1	FAL#	VIO	2
3	DEG#	GND	4
5	PRST#	GND	6
7	PS-ON	+5V	8
9	PWROK	+3.3V	10
11	+12V	5VSTBY	12
13	-12V	-5V	14

CompactPCI Reference Sheet

OTHER CONNECTORS

Utility Connector (20 pins)

Current: 1 A per pin
 Insulation Resistance: >1 x 10 Ω @ 500V DC
 Dielectric Strength: 1000 VRMS @ Sea Level
 Temperature: -55°C to + 125°C

Pin	Signal	Signal	Pin
1	FAL#	VIO	2
3	DEG#	GND	4
5	PRST# 1	GND	6
7	PRST# 2	+5V	8
9	INH#	+3.3V	10
11	+12V	EN#	12
13	-12V	-5V	14
15	IPMB PWR 2	IPMB SCL 2	16
17	IPMB SDA 2	IPMB PWR 1	18
19	IPMB SCL 1	IPMB SDA 1	20

Disk Drive Connector (4 pins)

Environmental
 Temperature Range, Storage: -55°C to 125°C
 Temperature Range, Operating: -25°C to 85°C
 Humidity: 90% R.H. non-condensing
 Shock and Vibration: Exceeds ETS 300-019-2-5

Pin	Signal
1	+5V
2	GND
3	GND
4	+12V

CompactPCI Reference Sheet

OTHER CONNECTORS

Positronic Power Connector (47 pins)

Insulator:	Glass-filled Polyester
Contacts:	Copper alloy with gold flash over nickel
Current:	Size 16 contacts (positions 45, 46, 47)- 40 A continuous (positions 1-20)- 28 A continuous Size 22 signal contacts-3 A nominal
Removable Contact Retention:	Size 16 contacts- 67 N (15 lbs) Size 22 N (6 lbs)
Fixed Contact Retention:	Size 16 contacts- 45 N (10 lbs) Size 22 contacts- 27 N (6 lbs)
Initial Contact Resistance:	
Maximum:	Size 16 contact- .0007 ohms max. Size 22 contact- .004 ohms max.
Flammability:	UL 94V-0
Working Temperature:	-55°C to + 125°C

Pin#	Staging	Signal Name	Description
1-4	M	V1	V1 Output
5-12	M	RTN	V1 and V2 Return
13-18	M	V2	V2 Output
19	M	RTN	V3 Return
20	M	V3	V3 Output
21	M	V4	V4 Output
22	M	RTN	Signal Return
23	M	Reserved	Reserved
24	M	RTN	V4 Return
25	M	GA0	Geog. Address Bit 0
26	M	Reserved	Reserved
27	S	EN#	Enable
28	M	GA1	Geog. Address Bit 1
29	M	V1ADJ	V1 Adjust
30	M	V1 Sense	V1 Remote Sense
31	M	GA2	Geog. Address Bit 2
32	M	V2ADJ	V2 Adjust
33	M	V2 Sense	V2 Remote Sense
34	M	S RTN	Sense Return
35	M	V1 Share	V1 Current Share
36	M	V3 Sense	V3 Remote Sense
37	M	IPMB_SCL	Reserved-SMB
38	M	DEG#	Degrade Signal
39	M	INH#	Inhibit
40	M	IPMB_SDA	Reserved-SMB
41	M	V2 Share	V2 Current Share
42	M	FAL#	Fail Signal
43	M	IPMB_PWR	Reserved-SMB
44	M	V3 Share	V3 Current Share
45	L	CGND	Chassis Ground
46	M	ACN/+ DC IN	AC Input-Neutral
47	M	ACL/-DC IN	AC Input-Line

* Pin numbers illustrated are of the female backplane connector

* L= long length pins (first mate, last break)

M= medium length pins

S= short length pins

CompactPCI Reference Sheet

CONDUCTOR RESISTANCE*

$$R = 0.6787e-6(1/TW)$$

T = etch thickness

W = etch width

Elma Bustronic typically uses 0.5 oz, 1.0 oz, or 2.0 oz of copper, translated to T = .7 mil, 1.4 mil, and 2.8 mil respectively. Etch width varies from 4 to 15 mil. *per IPC-D-275

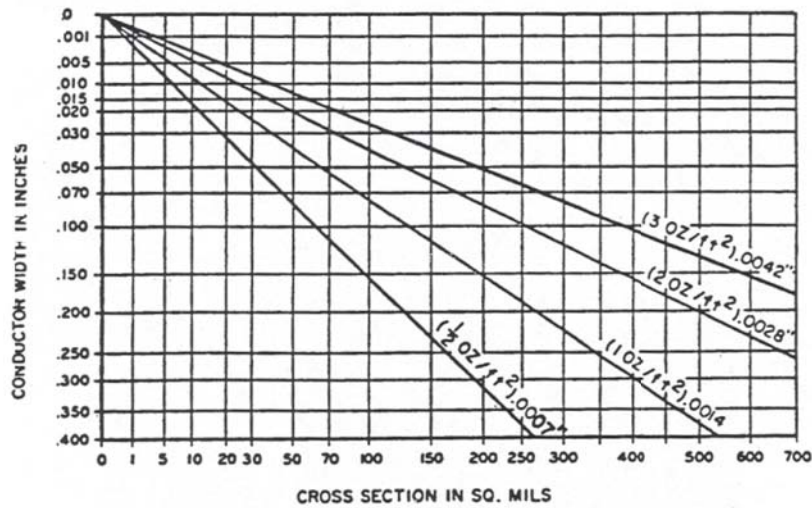
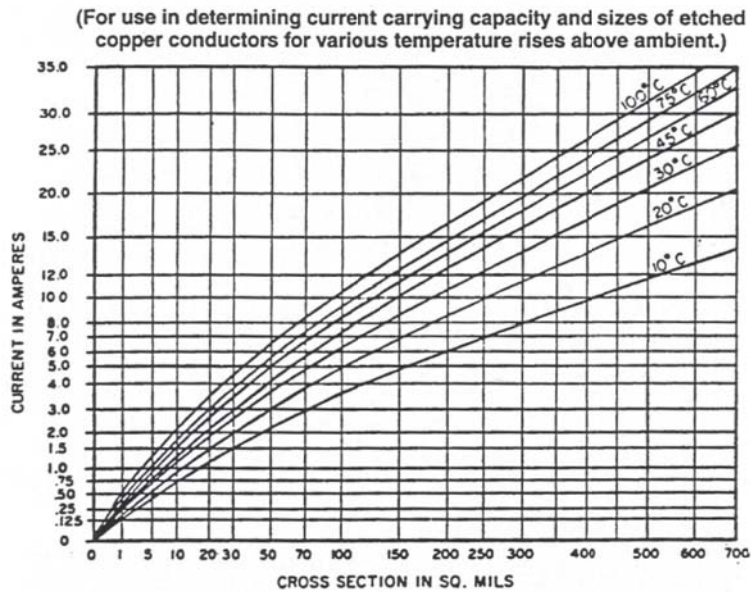

CompactPCI Reference Sheet

POWER INTERFACE SPECIFICATIONS

Power and Utility Connections

The 6/32 PEM Nuts used in Elma Bustronic's standard 3U and 6U cPCI backplanes do not have electrical current ratings. As a general guideline, Power bugs or taps are rated at 22 A per connection (30°C rise). Faston blades are an option at 12 A per blade and take up less space. The M4 screw stud is another termination option, rated at 18 A.

Power Bugs

Material:	Copper Alloy 725
Current:	22A @ 30°C rise
Contact Resistance:	2m max.
Insertion Force:	400 lbs. max.
Retention Force:	80 lbs. min.
Thread Torque:	8 in.-lbs. max.
Temperature:	-55°C to + 105°C

PEM Nuts (6-32)

Material:	Stainless Steel
Insertion Force:	500 lbs. max.
Retention Force:	80 lbs. min.
Torque-Out:	30 in.-lbs. min.

Hot Swap Basic Model

Hot Swap Basic Model
 Healthy # (P1-B4) open and bypassed w/.01uF cap
 PCI-Reset # (P1-C5) bussed to all slots
 Individual clock lines for each slot
 BD-SEL # (P1-D15) grounded at each slot

IDENTIFYING BACKPLANES

Basic Backplane Characteristic	How to Identify
PICMG 2.0 R3.0	Brown P4 key
PICMG 2.1 R2.0	Type AB rear shrouds on P3, P5
H.110/CT per PICMG 2.5 R1.0	Red P4 key Type AB rear shrouds on P3, P5
64-bit Backplane	Short tail P2- no P2 rear shroud
32-bit Backplane	Long tail P2 - w/ P2 rear shroud
5V V(I/O)	Blue P1 key
3.3V V(I/O)	Yellow P1 key

Backplane Connector Keys	
Connector Key	Backplane Characteristic
Brown P4 Key	P4 is rear I/O pass-through (no backplane connections to P4 signal pins)
Red P4 Key	P4 is H.110/CT bus per PICMG 2.5 R1.0
P4 Key NOT Installed	Backplane is NOT to latest specifications
Blue P1 Key	5V V(I/O)
Yellow P1 Key	3.3V V(I/O)

CompactPCI Reference Sheet

CPCI 64-BIT PIN ASSIGNMENTS

Pin #	Row Z	Row A	Row B	Row C	Row D	Row E	Row F	P1
25	GND	5V	REQ4	ENUM#	3.3V	5V	GND	
24	GND	AD[1]	5V	V(I/O)	AD[0]	ACK64#	GND	
23	GND	3.3V	AD[4]	AD[3]	5V	AD[2]	GND	
22	GND	AD[7]	GND	3.3V	AD[6]	AD[5]	GND	
21	GND	3.3V	AD[9]	AD[8]	M66EN	C/BE[0]	GND	
20	GND	AD[12]	GND	V(I/O)	AD[11]	AD[10]	GND	
19	GND	3.3V	AD[15]	AD[14]	GND	AD[13]	GND	
18	GND	SERR#	GND	3.3V	PAR	C/BE[1]#	GND	
17	GND	3.3V	IPMB_SCL	IPMB_SDA	GND	PERR#	GND	
16	GND	DEVSEL#	GND	V(I/O)	STOP#	LCK#	GND	
15	GND	3.3V	FRAME#	IRDY#	GND	TRDY#	GND	
12-14 Key Area								
11	GND	AD[18]	AD[17]	AD[16]	GND	C/BE[2]	GND	
10	GND	AD[21]	GND	3.3V	AD[20]	AD[19]	GND	
9	GND	C/BE[3]	IDSEL	AD[23]	GND	AD[22]	GND	
8	GND	AD[26]	GND	V(I/O)	AD[25]	AD[24]	GND	
7	GND	AD[30]	AD[29]	AD[28]	GND	AD[27]	GND	
6	GND	REQ#	GND	3.3V	CLK	AD[31]	GND	
5	GND	BRSVP1A5	BRSVP1B5	RST#	GND	GNT#	GND	
4	GND	IPMB_PWR	GND	V(I/O)	INTP	INTS	GND	
3	GND	INTA#	INTB#	INTC#	5V	INTD#	GND	
2	GND	TCK	5V	TMS	TDO	TDI	GND	
1	GND	5V	-12V	TRST#	+12V	5V	GND	

CompactPCI Reference Sheet

CPCI 64-BIT PIN ASSIGNMENTS

Pin #	Row Z	Row A	Row B	Row C	Row D	Row E	Row F	P2
22	GND	GA4	GA3	GA2	GA1	GA0	GND	
21	GND	CLK6	GND	RSV	RSV	RSV	GND	
20	GND	CLK5	GND	RSV	GND	RSV	GND	
19	GND	GND	GND	RSV	RSV	RSV	GND	
18	GND	BRSVP2A18	BRSVP2B18	BRSVP2C18	GND	BRSVP2E18	GND	
17	GND	BRSVP2A17	GND	PRST#	REQ6#	GNT6#	GND	
16	GND	BRSVP2A16	BRSVP2B16	DEG#	GND	BRSVP2E16	GND	
15	GND	BRSVP2A15	GND	FAL#	REQ5#	GNT5#	GND	
14	GND	AD[35]	AD[34]	AD[33]	GND	AD[32]	GND	
13	GND	AD[38]	GND	V(I/O)	AD[37]	AD[36]	GND	
12	GND	AD[42]	AD[41]	AD[40]	GND	AD[39]	GND	
11	GND	AD[45]	GND	V(I/O)	AD[44]	AD[43]	GND	
10	GND	AD[49]	AD[48]	AD[47]	GND	AD[46]	GND	
9	GND	AD[52]	GND	V(I/O)	AD[51]	AD[50]	GND	
8	GND	AD[56]	AD[55]	AD[54]	GND	AD[53]	GND	
7	GND	AD[59]	GND	V(I/O)	AD[58]	AD[57]	GND	
6	GND	AD[63]	AD[62]	AD[61]	GND	AD[60]	GND	
5	GND	C/BE[5]#	GND	V(I/O)	C/BE[4]	PAR64	GND	
4	GND	V(I/O)	BRSVP2B4	C/BE[4]	GND	C/BE[6]	GND	
3	GND	CLK4	GND	GNT3#	REQ4#	GNT4#	GND	
2	GND	CLK2	CLK3	SYSEN#	GNT2#	REQ#3	GND	
1	GND	CLK1	GND	REQ1#	GNT1#	REQ#2	GND	

CompactPCI Reference Sheet

H.110 CTCL PIN ASSIGNMENTS

Pin #	Row Z	Row A	Row B	Row C	Row D	Row E	Row F	P4
25	NP	SGA4	SGA3	SGA2	SGA1	SGA0	FG	
24	NP	GA4	GA3	GA2	GA1	GA0	FG	
23	NP	+12V	/CTREST	/CT_EN	-12V	CT_MC	FG	
22	NP	PFSO#	RSVD	RSVD	RSVD	RSVD	FG	
21	NP	-SLEVBAT	PFS1#	RSVD	RSVD	SELVBATRTRN	NP	
20	NP	NP	NP	NP	NP	NP	NP	
19	NP	NP	NP	NP	NP	NP	NP	
18	NP	VRG	NP	NP	NP	VRGRTRN	NP	
17	NP	NP	NP	NP	NP	NP	NP	
16	NP	NP	NP	NP	NP	NP	NP	
15	NP	-VBAT	NP	NP	NP	VBATRTRN	NP	
12-14 Key Area								
11	NP	CT_D29	CT_D30	CT_D28	V(I/O)	/CT_FRAME_B	GND	
10	NP	CT_D27	+3.3V	CT_D32	+5V	/CT_FRAME_A	GND	
9	NP	CT_D24	CT_D25	CT_D26	GND	/FR_COMP	GND	
8	NP	CT_D21	CT_D22	CT_D20	+5V	CT_C8_B	GND	
7	NP	CT_D19	+5V	CT_D24	GND	CT_C8_A	GND	
6	NP	CT_D16	CT_D17	CT_D18	GND	CT_NETREF_1	GND	
5	NP	CT_D13	CT_D14	CT_D15	+3.3V	CT_NETREF_2	GND	
4	NP	CT_D11	+5V	CT_D12	+3.3V	SCLK	GND	
3	NP	CT_D8	CT_D9	CT_D10	GND	SCLK-d	GND	
2	NP	CT_D4	CT_D5	CT_D1	CT_D7	GND	GND	
1	NP	CT_D0	+3.3V	CT_D7	CT_D2	CT_D3	GND	

CompactPCI Reference Sheet

GEOGRAPHICAL ADDRESSING*

Physical Slot Address

Physical Slot #	GA (4) (J2-A22)	GA (3) (J2-B22)	GA (2) (J2-C22)	GA (1) (J2-D22)	GA (0) (J2-E22)
0 ⁽¹⁾	GND	GND	GND	GND	GND
1	GND	GND	GND	GND	Open
2	GND	GND	GND	Open	GND
3	GND	GND	GND	Open	Open
4	GND	GND	Open	GND	GND
5	GND	GND	Open	GND	Open
6	GND	GND	Open	Open	GND
7	GND	GND	Open	Open	Open
8	GND	Open	GND	GND	GND
9	GND	Open	GND	GND	Open
10	GND	Open	GND	Open	GND
11	GND	Open	GND	Open	Open
12	GND	Open	Open	GND	GND
13	GND	Open	Open	GND	Open
14	GND	Open	Open	Open	GND
15	GND	Open	Open	Open	Open
16	Open	GND	GND	GND	GND
17	Open	GND	GND	GND	Open
18	Open	GND	GND	Open	GND
19	Open	GND	GND	Open	Open
20	Open	GND	Open	GND	GND
21	Open	GND	Open	GND	Open
22	Open	GND	Open	Open	GND
23	Open	GND	Open	Open	Open
24	Open	Open	GND	GND	GND
25	Open	Open	GND	GND	Open
26	Open	Open	GND	Open	GND
27	Open	Open	GND	Open	Open
28	Open	Open	Open	GND	GND
29	Open	Open	Open	GND	Open
30	Open	Open	Open	Open	GND
31	Open	Open	Open	Open	Open

Note: (1) Physical slot number "0" is reserved for future use.

*per PICMG 2.0 Rev. 3.0