

**Model: BPA-C300-120**  
**Single Output 300W**

The **BPA-C300-120** is a highly reliable cPCI Serial power supply used for CompactPCI Serial Systems. Capable of delivering up to 300W with customer supplied 20CFM forced air cooling. With a full range input of 90-264VAC, this power supply module achieves the highest performance and efficiency by incorporating LLC half bridge typology and synchronous rectification. The BPA-C300 family also includes PMBus™ interface to monitor and control all essential functions of the power supply module.

**Custom controls available.**



**Special Features**

- High efficiency up to 90.0%
- 300W with customer supplied 20 CFM forced air cooling
- Active Power Factor Correction
- Wide input voltage range: 90 – 264VAC
- Redundant operation
- Remote Sense (Standard on E and EC Models)
- Hot insertion/removal (hot plug)
- Single wire current sharing
- I<sup>2</sup>C interface PMBus™ compatible for control, programming and monitoring
- Remote firmware upgrade capable
- Fully secure (OTP, OVP, OCP, SCP)
- LEDs Status: OK, Fault
- Pwr\_Fail, PS\_ON
- CE Compliant
- RoHS Compliant
- Three Year Warranty
- **Custom modifications available**



**Safety**

- UL & cUL: 62368-1, 2<sup>nd</sup> Edition
- UL & cUL: 60950-1, 2nd Edition, 2014-10-14 ( Information Technology Equipment – Safety – Part 1: General Requirements)
- IEC 60950-1 (2005)( 2nd Edition): Am 1:2009 + Am 2:2013
- CE Certification
- DEMKO EN 60950-1:2006/A11:2009, EN 60950-1:2006/A1:2010, EN 60950-1:2006/A12:2011, EN 60950-1:2006/A2:2013

**Applications**

- CompactPCI Serial Systems

Model #	Assignment	Voltages	Minimum	Maximum
BPA-C300-120	VO1	12V	0A	25.0A
	VO2	5VSB	0A	2.5A

Phone: 973-594-1800

[Salesteam@BluTekPower.com](mailto:Salesteam@BluTekPower.com)

## 1. Input Specifications

Parameter	Description/Condition	Min	Nom	Max	Units
$V_{i\ nom}$	Nominal Input Voltage	100		240	VAC
$V_i$	Input Voltage Ranges	Normal operating ( $V_{min}$ to $V_{max}$ )		264	VAC
$I_{i\ max}$	Max. Input Current	$V_{in} = 90VAC/60HZ, Full Load$		4.1	$A_{rms}$
$I_{i\ p}$	Inrush Current	264 $V_{rms}, 25^{\circ}C$		32	$A_p$
	Leakage Current			0.3	mA
$F_i$	Input Frequency	47	50/60	440	Hz
PF	Power Factor	$V_{in} = 230V/50Hz$		0.96	W/VA
$V_{i\ on}$	Turn-on Voltage	Ramping Up		89	VAC
$V_{i\ off}$	Turn-off Voltage	Ramping Down		79	VAC
Power <sub>i</sub>	Input Power	$V_{in} = 90VAC-264VAC$		366	W
		$V_{in} = 230V, 12V / 5A, 12V / 0.5A, T_A = 25^{\circ}C$		>88	
$\eta$	Efficiency without Fan	$V_{in} = 230V, 12V / 12.5A, 12V / 1.25A, T_A = 25^{\circ}C$		>90	%
		$V_{in} = 230V, 12V / 25A, 12V / 2.5A, T_A = 25^{\circ}C$		>90	
$T_{hold}$	Hold-up Time	5			mS

**1.1 Input Fuse** An internal 5A input fuse, in series with the input line, protects against severe defects.

**1.2 Inrush Current** When the power supply module is connected to the main input, it exhibits a low and short peak current due to an X-capacitance's initial charge. The internal bulk capacitor is charged through a controlled NTC circuit which will limit the inrush current.

**1.3 Power Factor Correction** Power factor correction (PFC) is achieved by controlling the input current waveform synchronous with the input voltage and this provides outstanding PFC results over wide input voltage and load ranges.

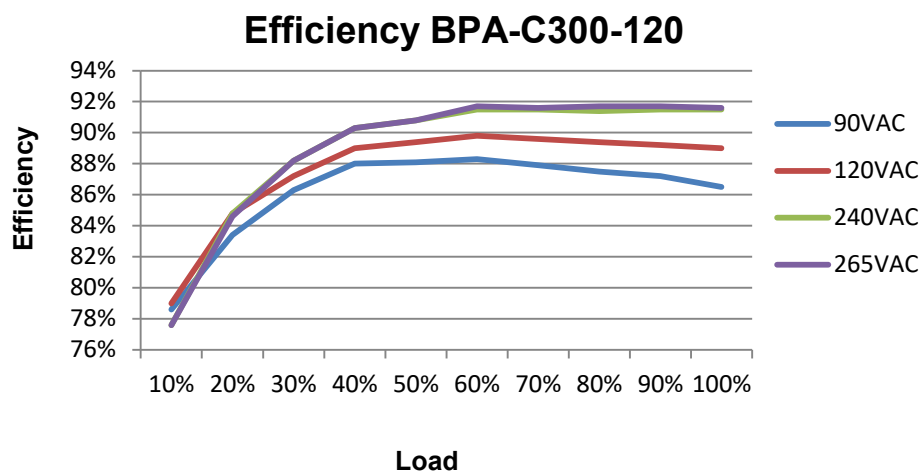

## 2. Output Specifications

Parameter	Description/Condition	Min	Nom	Max	Units		
<b>Main Output V<sub>1</sub></b>							
V <sub>1 nom</sub>	Nominal Output Voltage	0.5 · I <sub>1 nom</sub> , T <sub>amb</sub> =25°C		12.1	Vdc		
V <sub>1 set</sub>	Output Setpoint Accuracy	0.5 · I <sub>1 nom</sub> , T <sub>amb</sub> =25°C		-0.03	0.03	V <sub>1</sub>	
P <sub>1 nom</sub>	Nominal Output Power	V <sub>1</sub> =12 V <sub>DC</sub>		300		W	
I <sub>1 nom</sub>	Nominal Output Current	V <sub>1</sub> =12 V <sub>DC</sub>		25		A <sub>DC</sub>	
V <sub>1 pp</sub>	Output Ripple Voltage	V <sub>1 nom</sub> , I <sub>1 nom</sub> , 20MHz BW, T <sub>amb</sub> = 25°C		60		mV <sub>pp</sub>	
dV <sub>1 Load</sub>	Load Regulation	V <sub>i</sub> =V <sub>i nom</sub> , 0 - 100% I <sub>1 nom</sub>		-1	1	%V	
dV <sub>1 Line</sub>	Line Regulation	V <sub>i</sub> =V <sub>i min</sub> .....V <sub>i max</sub>		-0.5	0.5	%V	
dV <sub>1 tot</sub>	Total Regulation	V <sub>i min</sub> to V <sub>i max</sub> , 0 to 100% I <sub>1 nom</sub> , T <sub>a min</sub> to T <sub>a max</sub>		-1	1	%V <sub>1</sub>	
dI <sub>share</sub>	Current Sharing	when Bus load ≥ (20%)		-5	5	%A	
dI <sub>share</sub>	Current Sharing	when Bus load < (20%)		-5	5	%A	
dV <sub>dyn</sub>	Dynamic Load Regulation	I <sub>out</sub> :10%--50% of full load;50--100% of full load		2		3	%V
T <sub>rec</sub>	Recovery Time	dI <sub>1</sub> /dt =1A/μs, recovery within 1% of V <sub>1 nom</sub>		600		μs	
t <sub>AC V1</sub>	Start-up Time from AC	Varies with Input Line		3		sec	
tV <sub>1 rise</sub>	Rise Time	V <sub>1</sub> =10%.....90% V <sub>1 nom</sub>		30		ms	
C <sub>Load</sub>	Capacitive Loading	T <sub>amb</sub> =25°C		36000		μF	
<b>Standby Output V<sub>SB</sub></b>							
V <sub>SB nom</sub>	Nominal Output Voltage	0.5 · I <sub>1 nom</sub> , T <sub>amb</sub> =25°C		5.0		Vdc	
V <sub>SB set</sub>	Output Setpoint Accuracy	0.5 · I <sub>1 nom</sub> , T <sub>amb</sub> =25°C		-1	1	V <sub>SB</sub>	
P <sub>SB nom</sub>	Nominal Output Power	V <sub>SB</sub> = 12VDC		12.5		W	
I <sub>SB nom</sub>	Nominal Output Current	V <sub>SB</sub> = 12VDC		2.5		A <sub>DC</sub>	
V <sub>SB pp</sub>	Output Ripple Voltage	V <sub>SB</sub> , I <sub>SB</sub> , 20MHz BW, T <sub>amb</sub> = 25°C		60		mV <sub>pp</sub>	
dV <sub>SB tot</sub>	Total Regulation	V <sub>i min</sub> to V <sub>i max</sub> , 0 to 100% I <sub>1 nom</sub> , T <sub>a min</sub> to T <sub>a max</sub>		-1	1	%V <sub>SB</sub>	
dV <sub>SB</sub>	Droop	0 - 100% I <sub>SB nom</sub>		5.2	4.8	V	
dV <sub>SBdyn</sub>	Dynamic Load Regulation	ΔI <sub>SB</sub> = 50%, I <sub>SB nom</sub> , I <sub>SB</sub> 5.....100% I <sub>SB nom</sub> ,		-0.3	0.3	%V <sub>SB</sub>	
T <sub>rec</sub>	Recovery Time	dI <sub>1</sub> /dt =1A/μs, recovery within 1% of V <sub>SB nom</sub>		200		μs	
t <sub>AC VSB</sub>	Start-up Time from AC	Varies with Input Line		.7	1	sec	
tV <sub>SB rise</sub>	Rise Time	V <sub>SB</sub> = 10% .....90%V <sub>SB nom</sub>		6		mS	
C <sub>Load</sub>	Capacitive Load	T <sub>amb</sub> =25°C		10000		μF	

**2.1. Output Voltage Ripple** Ripple and noise are measured with 0.1μF of ceramic capacitance and 10 μF of tantalum capacitance on each of the outputs.

### 3. Protection

Parameter	Description/Condition	Min	Nom	Max	Units
F <sub>1</sub>	Input Fuse	Not user accessible		5	A
V <sub>1 OV</sub>	Over Voltage Threshold V <sub>1</sub>	14.8		15.6	Vdc
t <sub>OV V1</sub>	Over Voltage Latch Off Time V <sub>1</sub>			150	ms
V <sub>SB OV</sub>	Over Voltage Threshold V <sub>SB</sub>	7		8	VSB
t <sub>OV VSB</sub>	Over Voltage Latch Off Time V <sub>SB</sub>			1	ms
I <sub>V1 lim</sub>	Current Limit	Auto Recovery		30	A
V <sub>1 SC Max</sub>	Short Circuit Current V <sub>1</sub>	V <sub>1</sub> < 3V		250	A
t <sub>V1 SC off</sub>	Short Circuit Time	Time when in short circuit		200	µs
T <sub>SD</sub>	Over Temperature Protection	Internal temperature		105	°C
	Recovery Temperature			70	°C
I <sub>VSB lim</sub>	Standby Current Limit	Auto Recovery		4.5	A

**3.1 Overvoltage Protection** The power supply module will shut down if the output voltage exceeds the over voltage threshold. The power supply module must be manually repowered by recycling AC Source, by toggle PS\_ON, or PMBus™ operation command.

**3.2 Overload Protection** The overload protection feature will reduce the output voltage to a safe dissipation level when the output power rating exceeds 110% of a maximum rated power. The unit will automatically return to regulation upon removal of the overload.

**3.3 Short-circuit Protection** The unit will withstand a continuous short without damage. It will automatically return to regulation upon removal of the short.

**3.4 Over Temperature Protection** The power supply module will shut down if temperature exceeds the over temperature threshold (internal temperature). The power supply module will restart when temperature falls below recovery temperature threshold. The power supply module can also be manually repowered by recycling AC Source, by toggle PS\_ON, or PMBus™ operation command.

### 4. Safety/Approval

Parameter	Description/Condition	Min	Nom	Max	Units
Agency Approvals	Approved to the latest edition of the following standards: CE Certified UL/cUL 60950-1 IEC/EN 60950-1 UL/cUL 62368-1 IEC/EN 62368-1 Demko EN 60950-1		Approved by independent body		
Isolation Strength	Input(L/N) to Case (PE)	2500	Basic		VDC
	Input (L/N) to Output	4242	Reinforced		VDC
	Output to Case (PE)	2500	Functional		VDC
Electrical Strength Test	Input to Case	2500			VDC
	Input to Output	4242			VDC

## 5. Electromagnetic Compatibility

### 5.1 Immunity

Parameter	Description/Condition	Criterion
ESD Contact Discharge	IEC/EN61000-4-2, Level 4 ±15kV	A
Radiated Electromagnetic Field	IEC/EN61000-4-3,Level 1 (1V/m) 2.0 - 2.7GHz IEC/EN61000-4-3,Level 2 (3V/m) 80-1000MHz,1.4-2.0GHz	A A
Electrical Fast Transients/ Burst	IEC/EN61000-4-4,level 2 AC port ±1kV,1 minute	A
Surge	IEC/EN61000-4-5, Level 2 AC port ±1kV,20sec CM Level 3 AC port ±2kV,20sec CM	A A
RF Conducted Immunity	IEC/EN 61000-4-6,Level 2, 3 V,CW,0.15 ... 80MHz Amplitude Modulation 1kHz/80%	A
Magnetic Field Immunity	IEC/EN 61000-4-8,Level 2 3A/m	A
Voltage Dips and Interruptions	IEC/EN61000-4-11 1.0% residual voltage, 0.5 cycle 2.0% residual voltage, 1 cycle 3.40% residual voltage, 5 cycles 4.70% residual voltage, 0.5 cycle 5.70% residual voltage, 25 cycles/50Hz 6.0% residual voltage, 250 cycles/50Hz	A B B A B B

### 5.2 Emission

Parameter	Description/Condition	Criterion
Conducted Emissions	EN 55022 / EN 55016-2-1 conducted	Class B
Radiated Emission	EN 55022 / EN 55016-2-1 conducted	Class B
Harmonics Emission	IEC61000-3-2,Vin =230VAC/50Hz,100% Load	Class D
AC Flicker	IEC61000-3-3,Vin=230VAC/50Hz,100% Load,<20Arms	Pass

## 6. Environmental Specifications

Parameter	Description/Condition	Min	Nom	Max	Units
T <sub>A</sub> Ambient Temperature	V <sub>i min</sub> to V <sub>i max</sub> ,I <sub>1 nom</sub> ,ISB nom	-40		70	°C
T <sub>S</sub> Storage Temperature	Non- operational	-40		85	°C
Altitude	Operational, above Sea Level		5000 16400		Meter Feet
RH Humidity	Non-condensing	5		95	%
Shock and Vibration Acceleration	EN 61373:2010 Category 1 Class B				

*Max ambient allowed for forced air cooling is 70°C.  
Convection cooling de-rated load, 77W.*

## 7. Reliability

Function	Minimum	Condition
MTBF	500Khrs	According to Telecordia SR-332, 25°C ambient with rated load

## 8. Signals and Controls

### 8.1 Electrical Characteristics

Parameter	Description/Condition	Min	Nom	Max	Unit
<b>PS_ON/Enable</b>					
V <sub>IL</sub>	Input Low Level Voltage	0		0.8	V
V <sub>IH</sub>	Input High Level Voltage	2.4		3.3	V
R <sub>puPS_ON</sub>	Internal Pull Up Resistor on PS_ON		2		k Ω
R <sub>puEnable</sub>	Internal Pull up Resistor on Enable		2		k Ω
<b>Pwr_Fail/ PSPresent</b>					
V <sub>IL</sub>	Input Low Level Voltage	0		0.8	V
V <sub>IH</sub>	Input High Level Voltage	2.4		5.3	V
I <sub>IL,H</sub>	Maximum Input Sink or Source Current	0		10	mA
R <sub>puPwr_Fail</sub>	Internal Pull Up Resistor on Pwr_Fail		1		k Ω
<b>SCL/SDA</b>					
V <sub>IL</sub>	Input Low Level Voltage	0		0.8	V
V <sub>IH</sub>	Input High Level Voltage	2.4		3.3	V
I <sub>IL,H</sub>	Maximum Input Sink or Source Current	-25		25	mA
R <sub>puSCL</sub>	Internal Pull Up Resistor on SCL		6.8		k Ω
R <sub>puSDA</sub>	Internal Pull Up Resistor on SDA		6.8		k Ω
<b>A0/A1/A2</b>					
V <sub>IL</sub>	Input Low Level Voltage	0		0.8	V
V <sub>IH</sub>	Input High Level Voltage	2.4		3.3	V
R <sub>puA0</sub>	Internal Pull Up Resistor on A0		4.7		k Ω
R <sub>puA1</sub>	Internal Pull Up Resistor on A1		4.7		k Ω
R <sub>puA2</sub>	Internal Pull Up Resistor on A2		4.7		k Ω
<b>PSPresent</b>					
R <sub>puPS_Pre</sub>	Internal Resistor to COM		100		Ω

**8.2 PS\_ON** The PS\_ON signal is used to remotely enable/disable the main output V1. This active-low pin is also used to clear any latched fault condition.

**8.3 PS\_Present** The PS\_Present signal is internally connected to COM. This active-low signal is used to indicate to a power distribution unit controller that the power supply module is fully engaged.

**8.4 Pwr\_Fail** The Pwr\_Fail is an active-high signal that indicates whether both VSB and V1 outputs are within regulation and AC input voltage is above 80VAC. This pin is active-low when V1 and VSB are not within regulation or when the ac voltage falls outside the requirements for more than 8ms.

**8.5 Current Share (12VCS)** When used in a redundant configuration, all the current share pins need to be interconnected in order to activate the sharing function. If a supply has an internal fault or is not turned on, the current share line will automatically disengage from the bus.

If current share is not required the current share pin can be left open.

**8.6 Remote Sense (+VS and -VS) (Standard on E and EC Models)** The main output incorporates sense lines to compensate for voltage drop across the load line.

1. (+) Sense connects to the positive rail of the equipment used. Maximum voltage drop of 200mV.
2. (-) Sense connects to the negative rail of the equipment used. Maximum voltage drop of 200mV.

If remote sense is not required the (+) Sense and (-) Sense pins can be left open.

### 8.7.1 Front LED

<b>Power Supply Condition</b>	<b>Green LED</b>	<b>Yellow LED</b>	<b>Pwr_Fail</b>
Normal Operation	On	Off	High
Standby Mode	Blink	Off	Low
<b>PSU Faults Condition</b>			
Input UnderVoltage	Off	Blink	Low
Over Temperature	Off	On	Low
Output OverVoltage	Off	On	Low
<b>PSU Warning Condition</b>			
Over Temperature	Off	Blink	High
Input Under Voltage	Off	Blink	Low
Output OverVoltage	On	Blink	High

See Page 4 ([3. Protections](#)) for fault Threshold.

For Faults the power supply module must be manually repowered by recycling AC Source, by toggle PS\_ON, or Pmbus™ operation command.

### 8.7.2 Warnings

<b>PSU Warning Triggers</b>	<b>Min</b>	<b>Nom</b>	<b>Max</b>	<b>Units</b>
Over Temperature		85		°C
Input UnderVoltage		<80		VAC
Output OverVoltage		12.9		VDC

**8.8 SDA & SCL** The I2C bus consist of a Serial Clock (SCL) and a Serial Data Line(SDA). Both signals lines are pull up internally to 3.3V bus via 6.8k ohm resistors, if customer requires stronger pull up resistors, it is possible to install additional pull up resistors in the customer’s backplane.

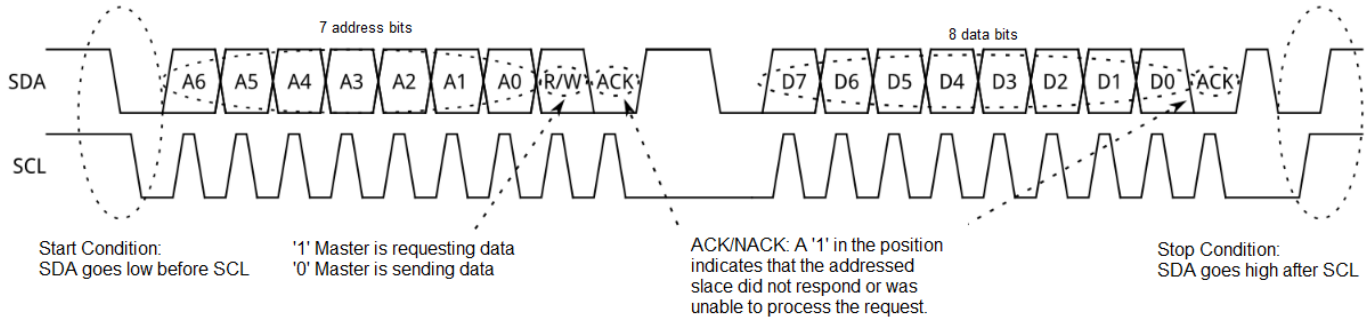

**8.9 Address Select (A0, A1, A2)** These digital input lines are used to set the address of the power supply module. These addresses are used to differentiate between multiple power supply modules utilize in a redundant mode within the same system.

**8.11 PSU Address Table** (Address Bit Settings)

A0, A1, & A2	PSU Address Value	A2	A1	A0	Recognize Address
00h	B0h	0	0	0	Yes
01h	B2h	0	0	1	Yes
02h	B4h	0	1	0	Yes
03h	B6h	0	1	1	Yes
04h	B8h	1	0	0	Yes
05h	BAh	1	0	1	Yes
06h	BCh	1	1	0	Yes
07h	BEh	1	1	1	Yes

**8.12 Pmbus™ Monitoring**

Parameter	Description/Condition	Min	Nom	Max	Units
V <sub>i mon</sub>	Input RMS Voltage V <sub>i min</sub> ≤ V <sub>i</sub> ≤ V <sub>i max</sub>	-3.5		3.5	%
I <sub>i mon</sub>	Input RMS Current	-2		2	%
P <sub>i mon</sub>	True Input Power	-4		4	%
V <sub>1 mon</sub>	V1 Voltage	-0.5		0.5	%
I <sub>1 mon</sub>	V1 Current	-2		-2	%
P <sub>o nom</sub>	Total Output Power	-1.5		-1.5	%
V <sub>SB mon</sub>	Standby Voltage	-1		1	%
I <sub>SB mon</sub>	Standby Current	-2		2	%
t <sub>1</sub>	Temperature1 Ambient Inside the Module	-2		2	°C
t <sub>2</sub>	Temperature2 Internal Secondary Components' Temperature	-2		2	°C

## 8.13 Timing Graph

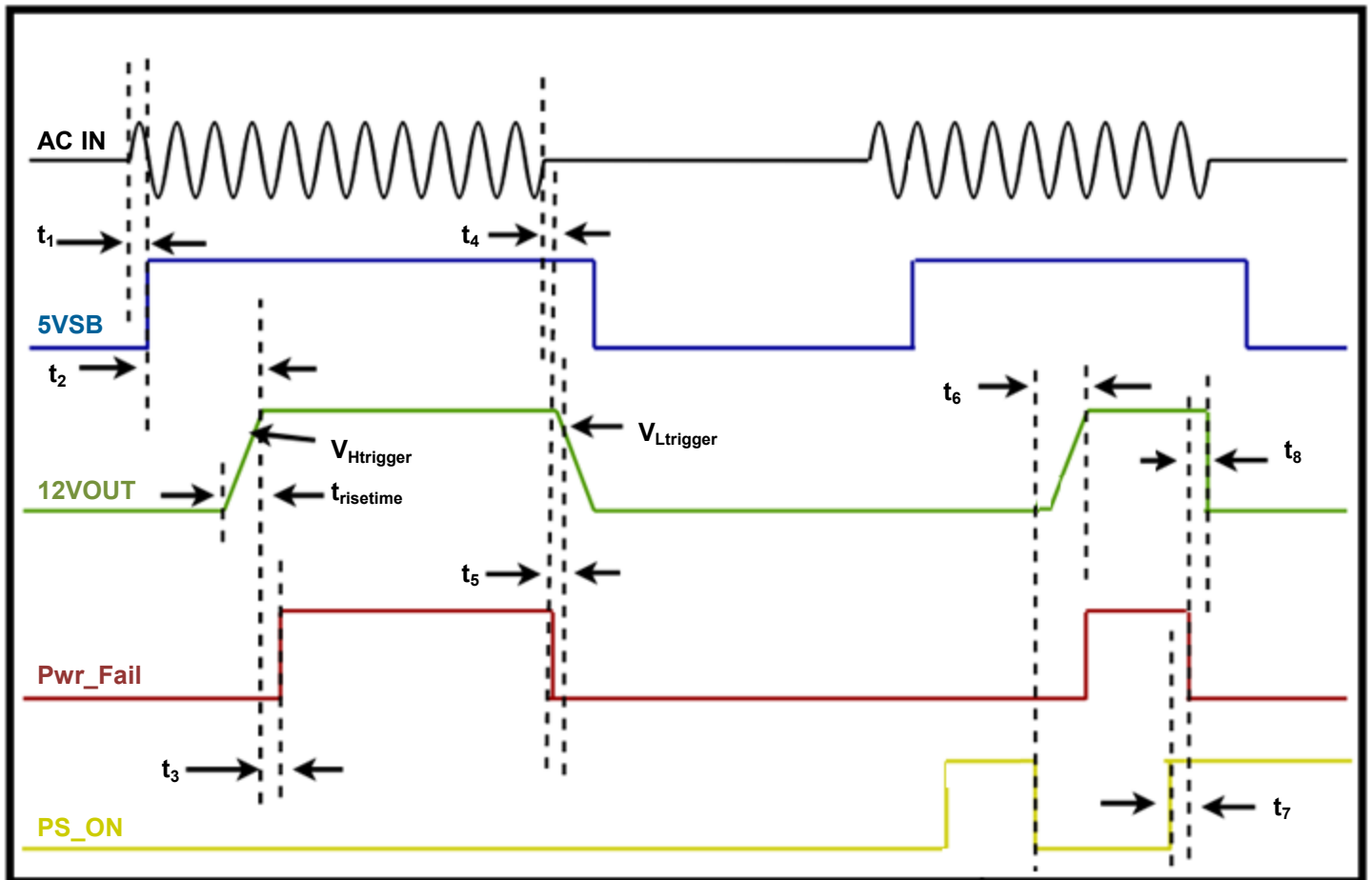

Parameter	Description/Condition	Min	Nom	Max	Unit
$t_{risetime}$	12VOUT, 0V to 12V	-	32	-	ms
$V_{Htrigger}$	Pwr_Fail(high)	11.4		11.8	V
$V_{Ltrigger}$	Pwr_Fail(low)	10.8		11.4	V
<b>Turn-On</b>					
$t_1$	AC IN - 5VSB	100		800	ms
$t_2$	5VSB - 12VOUT	-	1	-	s
$t_3$	12VOUT - Pwr_Fail(H)	-	500	600	ms
$t_6$	PS_ON(low) - 12VOUT	-	400	500	ms
<b>Turn-Off</b>					
$t_4$	AC IN - Pwr_Fail	6		-	ms
$t_5$	Pwr_Fail - 12VOUT	10		-	ms
$t_8$	PS_ON(high) - Pwr_Fail	-	420	-	ms
$t_7$	Pwr_Fail - 12VOUT	400		-	$\mu$ s

Phone: 973-594-1800

[Salesteam@BluTekPower.com](mailto:Salesteam@BluTekPower.com)

### 8.13 PMBus™ Functionality Supported By PSU(PMBus™ Info)

Address	Commands	Description	Supported	Transaction-Type	Byte_Size
00h	Page	Use to select which output gets reported via Read_VOUT, Read_IOUT & Read_POOUT commands, for PSU's with multiple outputs.	Y	Read/Write	2-bytes
01h	Operation_ON_OFF	Used to enable or disable the output of the PSU depending value of the second byte that follows.	Y	Read/Write	2-bytes
03h	Clear_Fault	Used to clear all status registers and error flags. This command also affects the SMB_ALERT signal.	Y	Write Only	1-byte
19h	Capability	Used by the end user system to query the PSU, to determine if it supports certain features, or not. Features such packet error checking, SMB_ALERT and the max SMBUS clock rate.	Y	Read Only	1-byte
79h	Status_Word	Used to retrieve and report two bytes containing a summary of faults conditions. All bits in this register should read as zero when the PSU is operating normally. This register acts as an index to all the other status registers.	Y	Read/Write	2-bytes
7Ah	Status_VOUT	Used to retrieve and report the status of the output voltages. It reports information such as output under-voltage, output over-voltage, output under voltage-warning	Y	Read/Write	1-byte
7Eh	Status_CML	Used to retrieve and report the status of the I2C or SMBUS communication bus; error such as packet error checking (PEC), receive an unsupported command etc...	Y	Read/Write	1-byte
88h	Read_VIN	Used to the a two bytes value in Little Endian format representing the active input voltage of the device in a linear format ( $VIN = Y \cdot 2^n$ ), where n is the exponent in two's complement represented by the five most significant bits of the upper byte. Y is the mantissa represented the eleven lower bits of the two byte word.	Y	Read Only	2-bytes
89h	Read_IIN	Used to retrieve a two bytes value in Little Endian format representing the active input current of the device in a linear format ( $IIN = Y \cdot 2^n$ ), where n is the exponent in two's complement represented by the five most significant bits of the upper byte. Y is the mantissa represented the eleven lower bits of the two byte word.	Y	Read Only	2-bytes

### 8.13 PMBus™ Functionality Supported By PSU(PMBus™ Info) - Continued

Address	Commands	Description	Supported	Transaction-Type	Byte_Size
8Bh	Read_VOUT	Used to retrieve a two bytes value in Little Endian format representing the active output voltage of the device in a linear format ( $V_{OUT} = Y \cdot 2^n$ ), where n is the exponent in two's compliment represented by the five most significant bits of the upper byte. Y is the mantissa represented the eleven lower bits of the two byte word.	Y	Read Only	2-bytes
8Ch	Read_IOUT	Used to retrieve a two bytes value in Little Endian format representing the active output current of the device in a linear format ( $I_{OUT} = Y \cdot 2^n$ ), where n is the exponent in two's compliment represented by the five most significant bits of the upper byte. Y is the mantissa represented the eleven lower bits of the two byte word.	Y	Read Only	2-bytes
8Dh	Read_Temperature_1	Used to retrieve a two bytes value in Little Endian format representing the air intake ambient temperature of the device in a linear format ( $Temp_1 = Y \cdot 2^n$ ), where n is the exponent in two's compliment format, represented by the five most significant bits of the upper byte. Y is the mantissa represented by the eleven lower bits of the two byte word.	Y	Read Only	2-bytes
8Eh	Read_Temperature_2	Used to retrieve a two bytes value in Little Endian format representing the air exhaust ambient temperature of the device in a linear format ( $Temp_2 = Y \cdot 2^n$ ), where n is the exponent in two's compliment format, represented by the five most significant bits of the upper byte. Y is the mantissa represented by the eleven lower bits of the two byte word.	Y	Read Only	2-bytes
96h	Read_POUT	Used to retrieve a two bytes value in Little Endian format representing the active output power of the device in a linear format ( $POUT = Y \cdot 2^n$ ), where n is the exponent in two's compliment format, represented by the five most significant bits of the upper byte. Y is the mantissa represented by the eleven lower bits of the two byte word.	Y	Read Only	2-bytes

### 8.13 PMBus™ Functionality Supported By PSU(PMBus™ Info) - Continued

Address	Commands	Description	Supported	Transaction-Type	Byte_Size
97h	Read_PIN	Used to retrieve a two bytes value in Little Endian format representing the active input power of the device in a linear format ( $PIN = Y \cdot 2^n$ ), where n is the exponent in two's compliment represented by the five most significant bits of the upper byte. Y is the mantissa represented by the eleven lower bits of the two byte word.	Y	Read Only	2-bytes
98h	PMBus™_Revision	Used to set and retrieve the version of the PMBus™ specification, with which the PSU is in compliance.	Y	Read Only	1-byte
9Ah	MFR_Model	Used to set and retrieve the manufacturer's model number assign to the device.	Y	Read/Write	Variable plus 1-byte count
9Bh	MFR_Revision	Used to set and retrieve the manufacturer's revision of the device.	Y	Read/Write	1-byte
9Ch	MFR_Location	Used to set and retrieve the location of manufacturing of the device.	Y	Read/Write	Variable plus 1-byte count
9Dh	MFR_Date	Used to set and retrieve the date of manufacturing of the device.	Y	Read/Write	4-bytes plus 1byte count
9Eh	MFR_Serial	Used to set and retrieve the value of the manufacturer's serial number assigned to the device.	Y	Read/Write	Variable plus 1-byte count
A0h	MFR_VIN_MIN	Used to retrieve the value of the minimum rated input voltage, that the PSU can be operated.	Y	Read Only	2-bytes
A1h	MFR_VIN_MAX	Used to retrieve the value of the maximum rated input voltage, that the PSU can be operated safely.	Y	Read Only	2-bytes
A2h	MFR_IIN_MAX	Used to retrieve the value of the maximum rated input current in Amps, that the PSU can be operated.	Y	Read Only	2-bytes
A3h	MFR_PIN_MAX	Used to retrieve the value of the maximum rated output power in Watts, that the PSU can be operated.	Y	Read Only	2-bytes
A4h	MFR_VOUT_MIN	Used to retrieve the value of the minimum rated output voltage that the PSU can provide.	Y	Read Only	2-bytes
A5h	MFR_VOUT_MAX	Used to retrieve the value of the maximum rated output voltage that the PSU can provide.	Y	Read Only	2-bytes
A6h	MFR_IOUT_MAX	Used to retrieve the value of the maximum rated output current in Amps, that the PSU is expected to provide.	Y	Read Only	2-bytes
A7h	MFR_POOUT_MAX	Used to retrieve the value of the maximum rated output power in Watts, that the PSU is expected provide.	Y	Read Only	2-bytes
A8h	MFR_TAMBIENT_MAX	Used to retrieve the value of the maximum ambient temperature that the PSU can be operated, in degree Celsius.	Y	Read Only	2-bytes
A9h	MFR__TAMBIENT_MIN	Used to retrieve the value of the minimum ambient temperature that the PSU can be operated, in degree Celsius.	Y	Read Only	2-bytes

Phone: 973-594-1800

[Salesteam@BluTekPower.com](mailto:Salesteam@BluTekPower.com)

## 9. Connection

### 9.1 Connectors

Input/Output ----- FCI51939-667

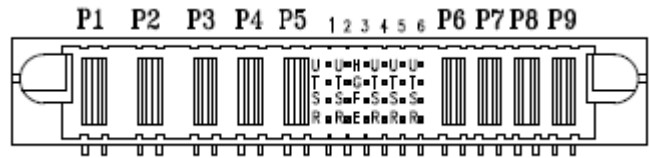

Note: H3, G3, E3 and F3 are short pins

P1	P2	P3	P4	P5	U1	U2	H3	U4	U5	U6	P6	P7	P8	P9
Line	Neutral	GND	NU	NU	NU	Pwr Fail	PSPresent	COM	Deg	5Vstby	COM	COM	12V Out	12V Out
					T1	T2	G3	T4	T5	T6				
					NU	NU	COM	A0	5Vstby	5Vstby				
					S1	S2	F3	S4	S5	S6				
					NU	12VCS	PSON	A1	SCL	COM				
					R1	R2	E3	R4	R5	R6				
NU	(-)VS	(+)VS	A2	SDA	Enable									

Pins	Pin Type	Assignment	Description/Function
<b>Control</b>			
E3	Signal Standard on E and EC Models	12VS(+)	(+) Sense - If remote sense is required this pin must be connected to the +12V load on the system backplane. This pin can be left open if remote sense is not required.
R2	Signal Standard on E and EC Models	12VS(-)	(-) Sense - If remote sense is required this pin must be connected to the 12V return on the system backplane. This pin can be left open if remote sense is not required.
S2	Signal	12VCS	Current Share - This pin must be connected to the 12V current share of the redundant power supplies on the system backplane. This pin can be left open if current share is not required.
T5,T6,U6	Signal House Keeping	5VSB	5V Stand by - This is the 5V standby output voltage pin.
H3	Signal	PS Present	Power Supply Present - This signal is connected to the common internally. This signal is used to identify that the power supply module is fully plugged into the system backplane.
F3	Signal	PS_ON	Power Supply On - This is the power supply module control pin. This pin must be directly connected to common or controlled by a transistor connected to common on the system backplane.
G3,U4,S6	Signal	COM	Common - This is the common return pin for the power supply module.
U2	Signal Open Collector	Pwr_Fail	Pwr_Fail - This pin is used to monitor the output voltage. The signal on this pin will go high about 500mSecs after the 12V output has reached regulation (above 10.8) and when the AC input voltage is above 80VAC. This signal will go low when the output voltage drops out of regulation (10.8V-11.4V) and when the AC input voltage drops below 80VAC. This pin must be connected to an external voltage via pull up resistor on the system backplane 20V max 10mA max.
U5	Signal Open Collector	Deg	Fault/Warning - An open collector signal is provided to indicate any fault or warning for over temperature.
R6	Signal	Enable	When driven high, main output is disabled. When Low, power supply main output state is as controlled by PS_ON
R5	Signal	SDA	Communication Data pin internal pulled up by a 6.8k $\Omega$ resistor.
S5	Signal	SCL	Communication Clock pin internal pulled up by a 6.8k $\Omega$ resistor.
T4	Signal	A0	Address Pin-This pin operates at 3.3V internal pulled up by a 4.7k $\Omega$ resistor.
S4	Signal	A1	Address Pin-This pin operates at 3.3V internal pulled up by a 4.7k $\Omega$ resistor.
R4	Signal	A2	Address Pin-This pin operates at 3.3V internal pulled up by a 4.7k $\Omega$ resistor.

Phone: 973-594-1800

[Salesteam@BluTekPower.com](mailto:Salesteam@BluTekPower.com)

## 10. Mechanical

Parameter	Description/Condition	Min	Nom	Max	Units
Dimension	Width		169.4(6.67)		mm(in)
	Height		128.5(5.06)		
	Depth		40.3(1.59)		
Weight			0.8(1.5)		Kg(lbs)

Front View

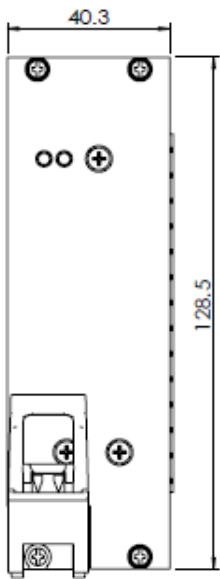

Top View

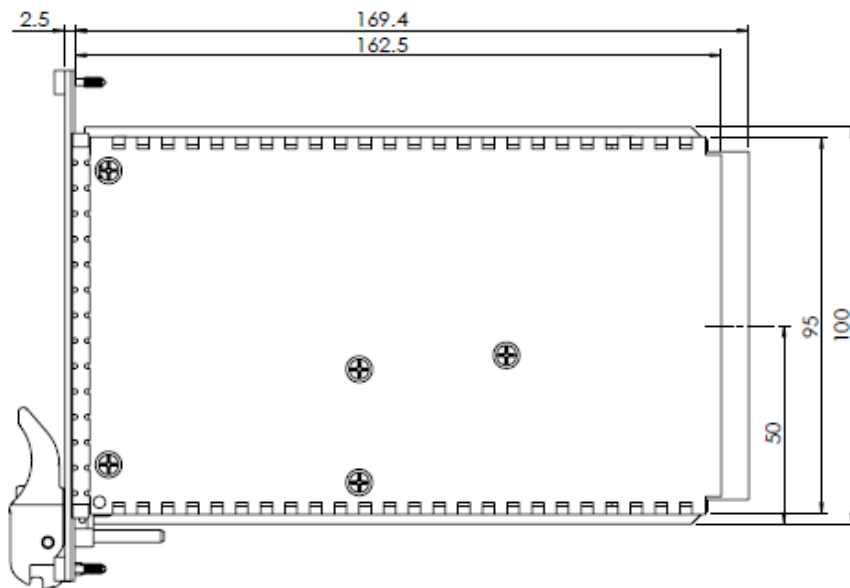

Rear View

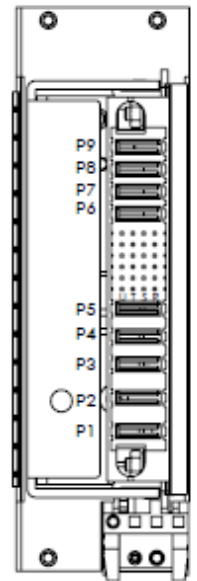

Side View

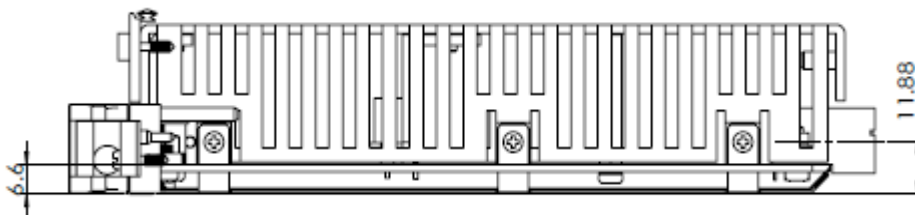

## 11. Ordering Information

### Model number matrix for BPA-CXXX-120XX

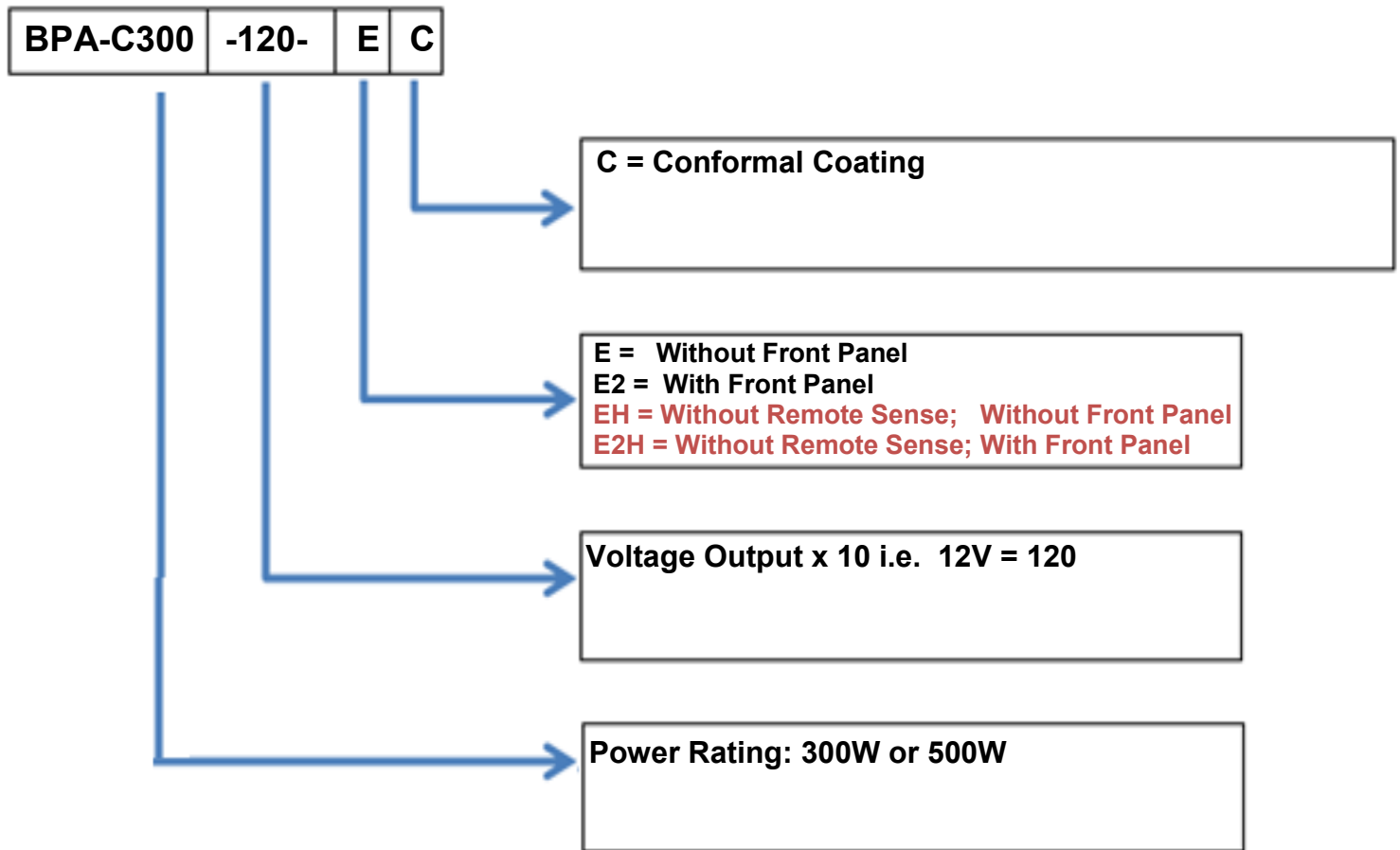

**Technical Revisions** – The appearance of products, including safety agency certification pictured on labels, may change depending on the date manufactured. Specifications are subject to change without notice.

### **Custom Modifications Available**

#### **Contact Info:**

Address: 300-1 Route 17 South Suite B2 Lodi, NJ 07644 USA  
Phone: 973-594-1800  
Email: [Salesteam@BluTekPower.com](mailto:Salesteam@BluTekPower.com)

***For more information on these products please contact a BluTek Sale Representative.***