



GBF

Grooving Tools for Small Parts Machining



High Precision Grooving Tools for Small Parts Machining

Large Tooling Lineup

Groove Widths from 0.041" to 0.094" and 0.25mm to 3.00mm and Maximum Groove Depths up to 3mm

Available Corner-R : 0.00/0.05/0.10 mm

Stable Chip Control with GL Chipbreaker

NEW JCTM Expansion
3/8" / 10mm Shank Sizes Added

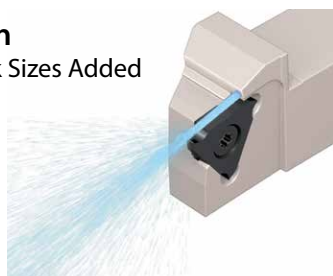

GBF

High Precision, Long Tool Life, and High Efficiency Machining with MEGACOAT Coating Technology

1 Large Tooling Lineup for a Variety of Small Part Operations

Inserts

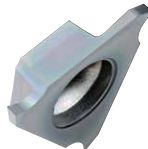
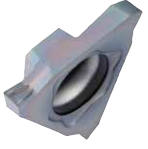
	Lineup	Features
 Ground Chipbreaker	Groove Width [CW] 0.041"~0.094" 0.25~0.65mm 0.75~2.00mm 2.25~3.00mm Each width of groove has both R-hand and L-hand	<ul style="list-style-type: none"> · Sharp Cutting Performance · Large Lineup
 Molded GL Chipbreaker	Groove Width [CW] (mm) 0.75~1.00 1.50~3.00 R-hand Only CornerR [RE] (mm) 0.05 0.10	<ul style="list-style-type: none"> · Excellent Chip Control · Stable Machining

1st Recommendation

Steel	PR1215 MEGACOAT
Stainless Steel	PR1535 MEGACOAT NANO
Non-Ferrous	GW15
Cast Iron	GW15

Coating Properties

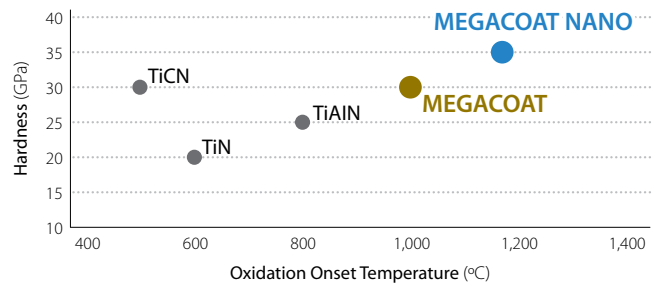

Toolholders

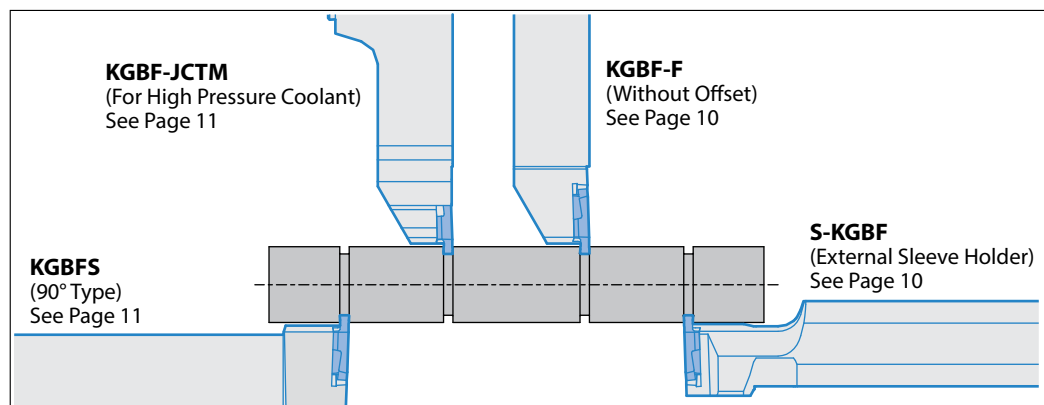

2 Stable Chip Control with GL Chipbreaker

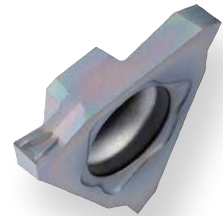

GL Chipbreaker maintains stable chip control while grooving and traversing
(Traversing is not recommended for GBF32R075-005GL)

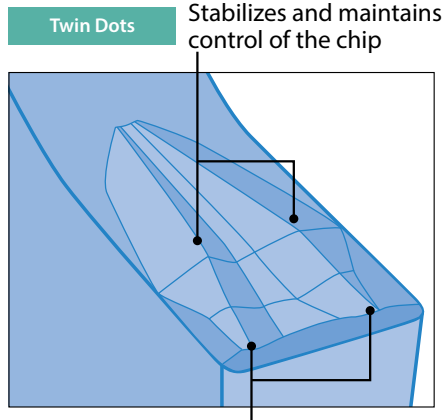

Front Edge Dots Curls chips and breaks them short to prevent chip clogging or entanglement.

Comparison of Chip Control (Internal Evaluation)

	GL Chipbreaker	Competitor A
Grooving d = 0.059" f = 0.0020 ipr		
Traversing D.O.C. = 0.008" f = 0.0016 ipr		

Cutting Conditions: Vc = 260 sfm, Insert width 0.039" (1mm)
Workpiece: 304

Case Studies

Nozzle Parts - Stainless Steel

Vc = 150 sfm
f = 0.002 ipr
Groove Depth 0.024"; Wet
KGBFR1212JX-16F
GBF32R100-005GL PR1535

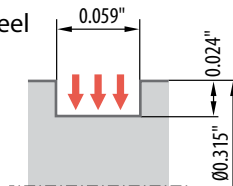

GL Chipbreaker PR1535



Competitor A



Competitor A's chips became entangled with workpiece due to unstable chip control.
GL Chipbreaker maintained stable chip control without entanglement.

(User Evaluation)

3 Good Surface Finish

GL Chipbreaker maintains stable chip control at high feed rates
Good surface finish of side wall

Surface Finish Comparison (Internal Evaluation)

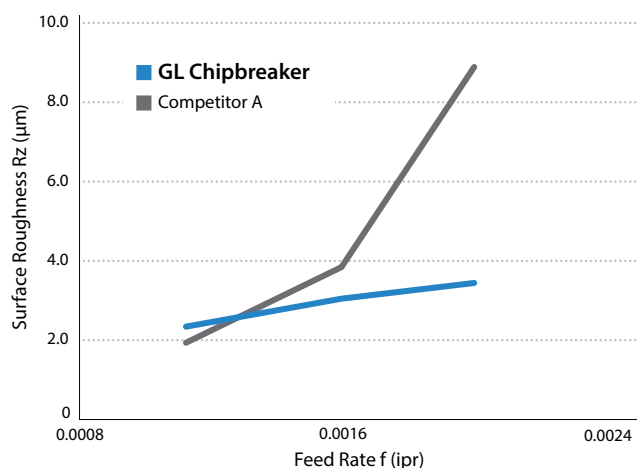

Chip Control Comparison (Internal Evaluation)

	f = 0.0012 ipr	f = 0.0016 ipr	f = 0.0020 ipr
GL Chipbreaker			
Competitor A (Molded Chipbreaker)			

Cutting Conditions: Vc = 260 sfm, d = 0.059", f = 0.0012~0.0020 ipr, Insert width 0.039" (1mm)
Workpiece: 4140

4 JCTM Series Direct Coolant Holder for Small Parts Machining

Supports internal coolant with or without piping systems

Internal coolant delivers improved chip control and longer tool life while grooving

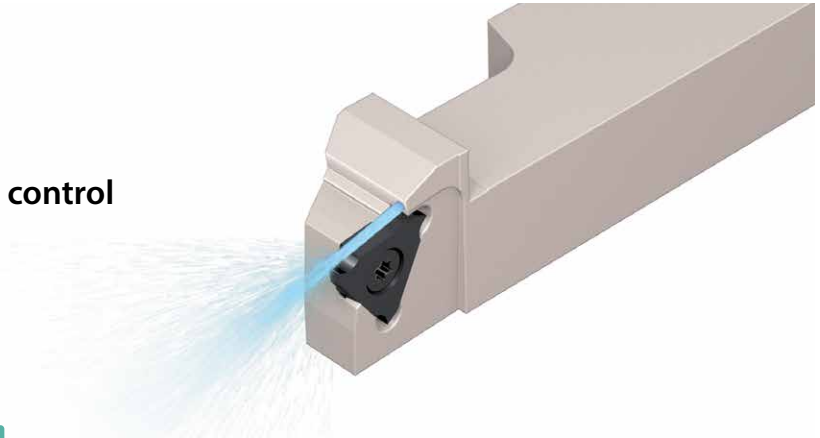

Internal Coolant without Piping

***When the tool plate supports direct coolant**

Coolant is supplied directly from the tool plate into the holder without the need to install piping

Applicable to Wide Range of Machines **The tool plate is optional. Please contact a Kyocera sales representative for details.**

CITIZEN MACHINERY CO., LTD. (L12(2M), L20(2M/3M), L32(2M), D25, M32(5M))
STAR MICRONICS CO., LTD. (SB Series, SD Series, SP Series)
TSUGAMI CORPORATION (B026/032-III Series, BW269/329ZJ, SS267/327-III Series, S205/206-II, S205A/206A-II)
Compatible with various machine including the above. Toolholders can be customized as well.

(Random order)
Based on Kyocera Survey in January 2021

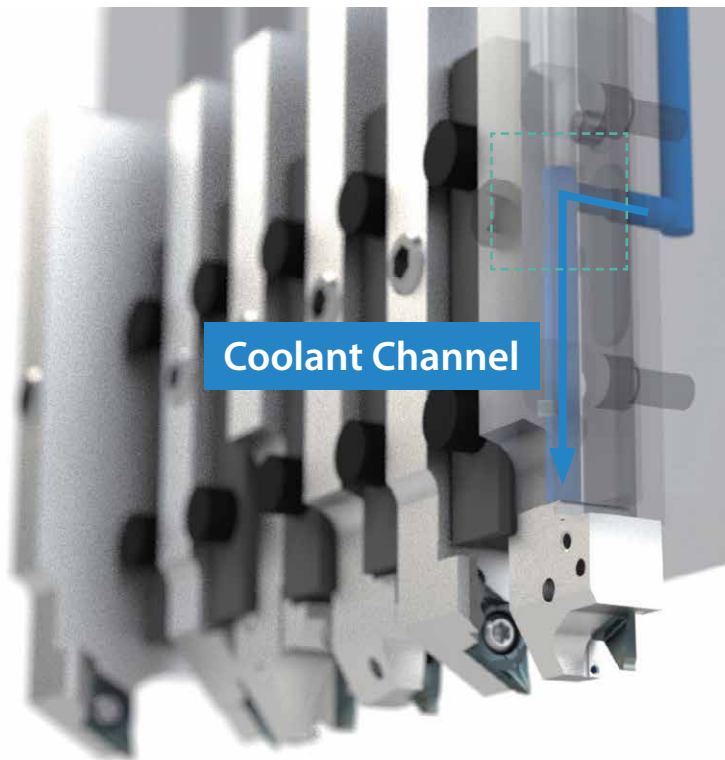

Optimized Coolant Supply

Supply hole designed to reduce energy loss based on extensive flow analysis

Analysis Image (Internal Evaluation)

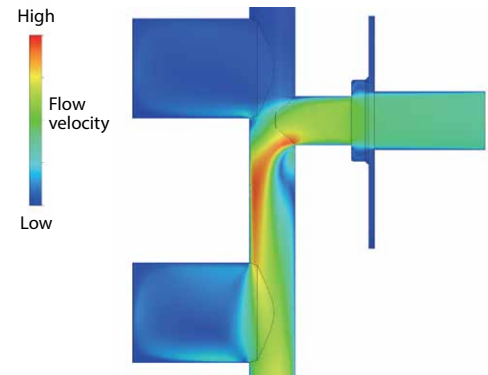

Compatible with internal coolant on any machine with standard piping parts

Commercial piping parts are available when using at normal pressure

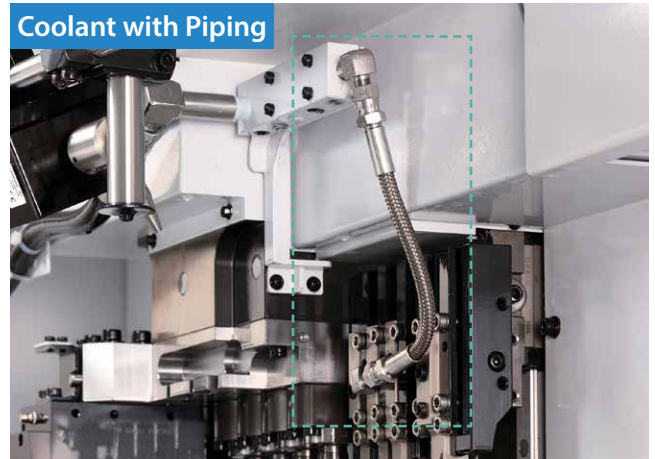

External Grooving KGBF-JCTM

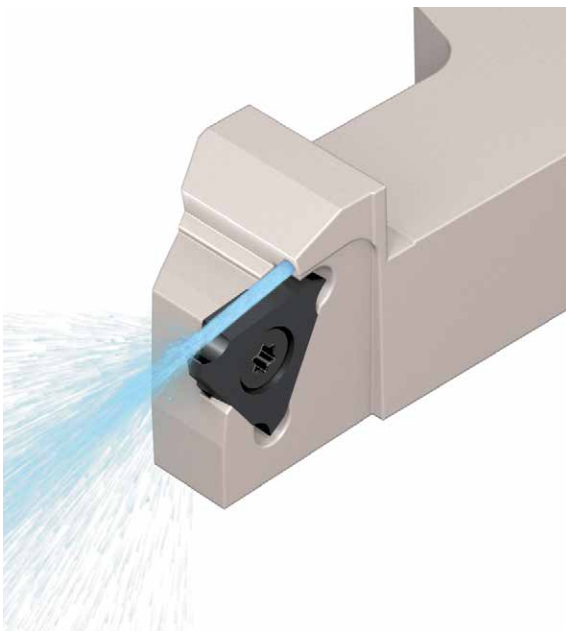

Discharges coolant from the top of the insert to deliver superior chip control and longer tool life

Edge Width : 0.010"-0.118" / 0.25mm-3.00mm

Ground Chipbreaker / Molded GL Chipbreaker

Maximum groove depth : 0.118" / 3mm

Coolant Discharging Comparison (Internal Evaluation)

Small chips and better cooling of the insert leads to longer tool life

- Cutting Edge
- Coolant Hole

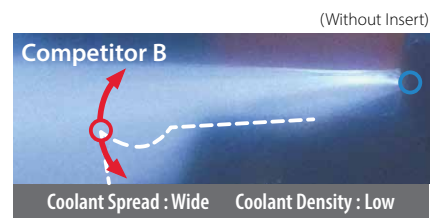
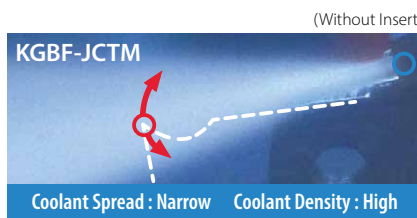
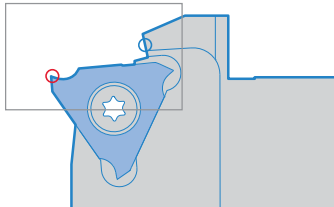

GBF Inserts (Sharp Edge / GL Chipbreaker)

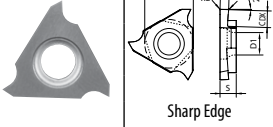
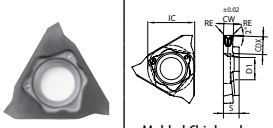
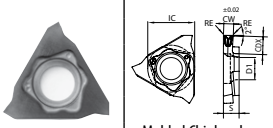
Insert Size							Carbon Steel / Alloy Steel							Titanium Alloy			P
IC		S		D1			Stainless Steel							Cast Iron			M
in	mm	in	mm	in	mm	mm	Non-Ferrous Metals							Titanium Alloy			K
3/8	9.525	1/8	3.18	0.173	4.4		Titanium Alloy										N
Insert		Part Number		No. of Edges	Dimensions (mm)							Tolerance (mm)		Carbide			Applicable Toolholder Page 10-12
					CW		CDX	IC	S	D1	RE	CW min.	CW max.	PVD			
					in	mm								PR1215	PR1535	GW15	
 <p>Sharp Edge</p>	GBF32R	025-000F	0.010	0.25	0.6	9.525	3.18	4.4	0	-0.02	+0.02	●	●	●	KGBFR...-16F KGBFR...-3... KGBFR...-16FJCTM KGBFSL...-16 S...KGBFL16		
		030-000F	0.012	0.3	0.8					-0.02	+0.02	●	●	●			
		033-000F	0.013	0.33	0.8					-0.025	+0.015	●	●	●			
		043-000F	0.017	0.43	1					-0.025	+0.015	●	●	●			
		050-000F	0.020	0.5	1.2					-0.02	+0.02	●	●	●			
		053-000F	0.021	0.53	1.2					-0.025	+0.015	●	●	●			
		065-000F	0.026	0.65	1.2					-0.02	+0.02	●	●	●			
		075-000F	0.030	0.75	2					-0.02	+0.02	●	●	●			
		080-000F	0.031	0.8	2					-0.02	+0.02	●	●	●			
		095-000F	0.037	0.95	2					-0.02	+0.02	●	●	●			
		100-000F	0.039	1	2					-0.02	+0.02	●	●	●			
		110-000F	0.043	1.1	2					-0.02	+0.02	●	●	●			
		120-000F	0.047	1.2	2					-0.02	+0.02	●	●	●			
		125-000F	0.049	1.25	2					-0.02	+0.02	●	●	●			
		130-000F	0.051	1.3	2					-0.02	+0.02	●	●	●			
		140-000F	0.055	1.4	2.7					-0.02	+0.02	●	●	●			
		145-000F	0.057	1.45	2.7					-0.02	+0.02	●	●	●			
		150-000F	0.059	1.5	2.7					-0.02	+0.02	●	●	●			
		165-000F	0.065	1.65	2.7					-0.02	+0.02	●	●	●			
		170-000F	0.067	1.7	3					-0.02	+0.02	●	●	●			
175-000F	0.069	1.75	3	-0.02	+0.02	●	●	●									
200-000F	0.079	2	3	-0.02	+0.02	●	●	●									
 <p>Molded Chipbreaker</p>	GBF32L	025-000F	0.010	0.25	0.6	9.525	3.18	4.4	0	-0.02	+0.02	●	●	●	KGBFL...-16F KGBFL...-3... KGBFSR...-16		
		030-000F	0.012	0.3	0.8					-0.02	+0.02	●	●	●			
		033-000F	0.013	0.33	0.8					-0.025	+0.015	●	●	●			
		043-000F	0.017	0.43	1					-0.025	+0.015	●	●	●			
		050-000F	0.020	0.5	1.2					-0.02	+0.02	●	●	●			
		053-000F	0.021	0.53	1.2					-0.025	+0.015	●	●	●			
		065-000F	0.026	0.65	1.2					-0.02	+0.02	●	●	●			
		075-000F	0.030	0.75	2					-0.02	+0.02	●	●	●			
		080-000F	0.031	0.8	2					-0.02	+0.02	●	●	●			
		095-000F	0.037	0.95	2					-0.02	+0.02	●	●	●			
		100-000F	0.039	1	2					-0.02	+0.02	●	●	●			
		110-000F	0.043	1.1	2					-0.02	+0.02	●	●	●			
		120-000F	0.047	1.2	2					-0.02	+0.02	●	●	●			
		125-000F	0.049	1.25	2					-0.02	+0.02	●	●	●			
		130-000F	0.051	1.3	2					-0.02	+0.02	●	●	●			
		140-000F	0.055	1.4	2.7					-0.02	+0.02	●	●	●			
		145-000F	0.057	1.45	2.7					-0.02	+0.02	●	●	●			
		150-000F	0.059	1.5	2.7					-0.02	+0.02	●	●	●			
		165-000F	0.065	1.65	2.7					-0.02	+0.02	●	●	●			
		170-000F	0.067	1.7	3					-0.02	+0.02	●	●	●			
175-000F	0.069	1.75	3	-0.02	+0.02	●	●	●									
200-000F	0.079	2	3	-0.02	+0.02	●	●	●									
 <p>Molded Chipbreaker</p>	GBF32R	075-005GL	0.030	0.75	2	9.525	3.18	4.4	0.05	-0.02	+0.02	●	●	●	KGBFR...-16F KGBFR...-3... KGBFR...-16FJCTM KGBFSL...-16 S...KGBFL16		
		095-005GL	0.037	0.95	2				0.05	-0.02	+0.02	●	●	●			
		100-005GL	0.039	1	2				0.05	-0.02	+0.02	●	●	●			
		150-010GL	0.059	1.5	2.7				0.1	-0.02	+0.02	●	●	●			
		200-010GL	0.079	2	3				0.1	-0.02	+0.02	●	●	●			
		300-010GL	0.118	3	3				0.1	-0.02	+0.02	●	●	●			

Right-hand shown
Max. Cutting Dia. : See Page 9

Recommended Cutting Conditions Page 13

● : Standard Item

GBF Inserts (Standard / Right-Hand)

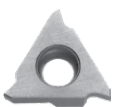
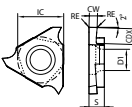
Insert Size	IC		S		D1		Carbon Steel / Alloy Steel											P
	in	mm	in	mm	in	mm	Stainless Steel											M
							Cast Iron											K
GBF32...	3/8	9.525	1/8	3.18	0.173	4.4	Non-Ferrous Metals											N
							Titanium Alloy											S
Insert	Part Number	No. of Edges	Dimensions (mm)						Tolerance (mm)			Carbide			Applicable Toolholder Page 10-12			
			CW		CDX	IC	S	D1	RE	CW min.	CW max.	PVD	-					
			in	mm									PR1215	PR1535		GW15		
 	GBF32R 025-005	3	0.010	0.25	0.6	9.525	3.18	4.4	0.05	-0.02	+0.02	●	●	●	KGBFR...-16F KGBFR...-3... KGBFR...-16FJCTM KGBFSL...-16 S...KGBFL16			
	030-005	0.012	0.3	0.8	0.05	-0.02	+0.02	●	●	●								
	033-005	0.013	0.33	0.8	0.05	-0.025	+0.015	●	●	●								
	043-005	0.017	0.43	1	0.05	-0.025	+0.015	●	●	●								
	050-005	0.020	0.5	1.2	0.05	-0.02	+0.02	●	●	●								
	053-005	0.021	0.53	1.2	0.05	-0.025	+0.015	●	●	●								
	065-005	0.026	0.65	1.2	0.05	-0.02	+0.02	●	●	●								
	075-005	0.030	0.75	2	0.05	-0.02	+0.02	●	●	●								
	075-010	0.030	0.75	2	0.1	-0.02	+0.02	●	●	●								
	080-005	0.031	0.8	2	0.05	-0.02	+0.02	●	●	●								
	080-010	0.031	0.8	2	0.1	-0.02	+0.02	●	●	●								
	095-005	0.037	0.95	2	0.05	-0.02	+0.02	●	●	●								
	095-010	0.037	0.95	2	0.1	-0.02	+0.02	●	●	●								
	100-005	0.039	1	2	0.05	-0.02	+0.02	●	●	●								
	100-010	0.039	1	2	0.1	-0.02	+0.02	●	●	●								
	041N	0.041	1.05	1	0.05	-0.03	+0.03	●	●	●								
	110-005	0.043	1.1	2	0.05	-0.02	+0.02	●	●	●								
	110-010	0.043	1.1	2	0.1	-0.02	+0.02	●	●	●								
	120-005	0.047	1.2	2	0.05	-0.02	+0.02	●	●	●								
	120-010	0.047	1.2	2	0.1	-0.02	+0.02	●	●	●								
	125-005	0.049	1.25	2	0.05	-0.02	+0.02	●	●	●								
	125-010	0.049	1.25	2	0.1	-0.02	+0.02	●	●	●								
	130-005	0.051	1.3	2	0.05	-0.02	+0.02	●	●	●								
	130-010	0.051	1.3	2	0.1	-0.02	+0.02	●	●	●								
	140-005	0.055	1.4	2.7	0.05	-0.02	+0.02	●	●	●								
	140-010	0.055	1.4	2.7	0.1	-0.02	+0.02	●	●	●								
	145-005	0.057	1.45	2.7	0.05	-0.02	+0.02	●	●	●								
	145-010	0.057	1.45	2.7	0.1	-0.02	+0.02	●	●	●								
	058N	0.058	1.47	1.2	0.1	-0.03	+0.03	●	●	●								
	150-005	0.059	1.5	2.7	0.05	-0.02	+0.02	●	●	●								
	150-010	0.059	1.5	2.7	0.1	-0.02	+0.02	●	●	●								
	062N	0.062	1.57	1.2	0.1	-0.03	+0.03	●	●	●								
	165-005	0.065	1.65	2.7	0.05	-0.02	+0.02	●	●	●								
	165-010	0.065	1.65	2.7	0.1	-0.02	+0.02	●	●	●								
	170-005	0.067	1.7	3	0.05	-0.02	+0.02	●	●	●								
	170-010	0.067	1.7	3	0.1	-0.02	+0.02	●	●	●								
	175-005	0.069	1.75	3	0.05	-0.02	+0.02	●	●	●								
	175-010	0.069	1.75	3	0.1	-0.02	+0.02	●	●	●								
	200-005	0.079	2	3	0.05	-0.02	+0.02	●	●	●								
	200-010	0.079	2	3	0.1	-0.02	+0.02	●	●	●								
225-005	0.089	2.25	3	0.05	-0.02	+0.02	●	●	●									
225-010	0.089	2.25	3	0.1	-0.02	+0.02	●	●	●									
094N	0.094	2.39	2	0.1	-0.03	+0.03	●	●	●									
250-005	0.098	2.5	3	0.05	-0.02	+0.02	●	●	●									
250-010	0.098	2.5	3	0.1	-0.02	+0.02	●	●	●									
300-005	0.118	3	3	0.05	-0.02	+0.02	●	●	●									
300-010	0.118	3	3	0.1	-0.02	+0.02	●	●	●									

Right-hand shown
Max. Cutting Dia. : See Page 9

Recommended Cutting Conditions Page 13

● : Standard Item

GBF Inserts (Standard / Left-Hand)

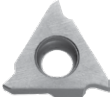
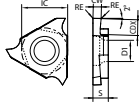
Insert Size							Carbon Steel / Alloy Steel							Titanium Alloy			P		
IC		S		D1			Stainless Steel							Cast Iron			M		
in	mm	in	mm	in	mm	mm											K		
3/8	9.525	1/8	3.18	0.173	4.4											N			
GBF32L...																	S		
Insert	Part Number	No. of Edges	Dimensions (mm)						Tolerance (mm)			Carbide			Applicable Toolholder Page 10-12				
			CW		CDX	IC	S	D1	RE	CW min.	CW max.	PVD		-					
			in	mm								PRI215	PRI535			GW15			
 	GBF32L 025-005	3	0.010	0.25	0.6	9.525	3.18	4.4	0.05	-0.02	+0.02	●	●	●	KGBFL...-16F KGBFL...-3... KGBFSR...-16				
	030-005	0.012	0.3	0.8	0.05	-0.02	+0.02	●	●	●									
	033-005	0.013	0.33	0.8	0.05	-0.025	+0.015	●	●	●									
	043-005	0.017	0.43	1	0.05	-0.025	+0.015	●	●	●									
	050-005	0.020	0.5	1.2	0.05	-0.02	+0.02	●	●	●									
	053-005	0.021	0.53	1.2	0.05	-0.025	+0.015	●	●	●									
	065-005	0.026	0.65	1.2	0.05	-0.02	+0.02	●	●	●									
	075-005	0.030	0.75	2	0.05	-0.02	+0.02	●	●	●									
	075-010	0.030	0.75	2	0.1	-0.02	+0.02	●	●	●									
	080-005	0.031	0.8	2	0.05	-0.02	+0.02	●	●	●									
	080-010	0.031	0.8	2	0.1	-0.02	+0.02	●	●	●									
	095-005	0.037	0.95	2	0.05	-0.02	+0.02	●	●	●									
	095-010	0.037	0.95	2	0.1	-0.02	+0.02	●	●	●									
	100-005	0.039	1	2	0.05	-0.02	+0.02	●	●	●									
	100-010	0.039	1	2	0.1	-0.02	+0.02	●	●	●									
	041N	0.041	1.05	1	0.05	-0.03	+0.03	●	●	●									
	110-005	0.043	1.1	2	0.05	-0.02	+0.02	●	●	●									
	110-010	0.043	1.1	2	0.1	-0.02	+0.02	●	●	●									
	120-005	0.047	1.2	2	0.05	-0.02	+0.02	●	●	●									
	120-010	0.047	1.2	2	0.1	-0.02	+0.02	●	●	●									
	125-005	0.049	1.25	2	0.05	-0.02	+0.02	●	●	●									
	125-010	0.049	1.25	2	0.1	-0.02	+0.02	●	●	●									
	130-005	0.051	1.3	2	0.05	-0.02	+0.02	●	●	●									
	130-010	0.051	1.3	2	0.1	-0.02	+0.02	●	●	●									
	140-005	0.055	1.4	2.7	0.05	-0.02	+0.02	●	●	●									
	140-010	0.055	1.4	2.7	0.1	-0.02	+0.02	●	●	●									
	145-005	0.057	1.45	2.7	0.05	-0.02	+0.02	●	●	●									
	145-010	0.057	1.45	2.7	0.1	-0.02	+0.02	●	●	●									
	058N	0.058	1.47	1.2	0.1	-0.03	+0.03	●	●	●									
	150-005	0.059	1.5	2.7	0.05	-0.02	+0.02	●	●	●									
	150-010	0.059	1.5	2.7	0.1	-0.02	+0.02	●	●	●									
	062N	0.062	1.57	1.2	0.1	-0.03	+0.03	●	●	●									
	165-005	0.065	1.65	2.7	0.05	-0.02	+0.02	●	●	●									
	165-010	0.065	1.65	2.7	0.1	-0.02	+0.02	●	●	●									
	170-005	0.067	1.7	3	0.05	-0.02	+0.02	●	●	●									
	170-010	0.067	1.7	3	0.1	-0.02	+0.02	●	●	●									
175-005	0.069	1.75	3	0.05	-0.02	+0.02	●	●	●										
175-010	0.069	1.75	3	0.1	-0.02	+0.02	●	●	●										
200-005	0.079	2	3	0.05	-0.02	+0.02	●	●	●										
200-010	0.079	2	3	0.1	-0.02	+0.02	●	●	●										
225-005	0.089	2.25	3	0.05	-0.02	+0.02	●	●	●										
225-010	0.089	2.25	3	0.1	-0.02	+0.02	●	●	●										
094N	0.094	2.39	2	0.1	-0.03	+0.03	●	●	●										
250-005	0.098	2.5	3	0.05	-0.02	+0.02	●	●	●										
250-010	0.098	2.5	3	0.1	-0.02	+0.02	●	●	●										
300-005	0.118	3	3	0.05	-0.02	+0.02	●	●	●										
300-010	0.118	3	3	0.1	-0.02	+0.02	●	●	●										

Right-hand shown
Max. Cutting Dia. : See Page 9

Recommended Cutting Conditions Page 13

● : Standard Item

GBA PCD Inserts

When using a KGBF/KGBFS holders to machine non-ferrous metals, etc.

Applicable PCD Insert

Insert Size	IC		S		D1	
	in	mm	in	mm	in	mm
GBA32	3/8	9.525	1/8	3.18	0.173	4.4

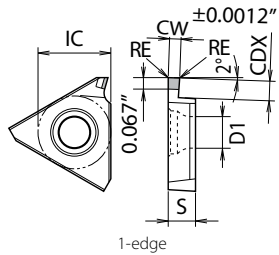
Insert	Part Number	Dimensions (mm)				PCD	
		CW		CDX	RE	KPD001	KPD010
		in	mm			R	R
	GBA32R 125-010	0.049	1.25	2.00	0.10	●	●
	150-010	0.059	1.50			●	●
	200-010	0.079	2.00	2.50		●	

· CDX shows available grooving depth.

● : Standard Item

When using a KGBF/KGBFS holder for non-ferrous metal machining, use a GBA PCD insert.

*See above details for insert description. Also, please refer to the precautions below when using.

Precautions

· GBF and GBA Compatibility

- GBF will fit KGBA/KGBAS holders.
Caution : The maximum groove depth for KGBA/KGBAS holders is 0.098" (2.5mm)
- GBA inserts will also fit KGBF/KGBFS holders
Caution : The rake angle after installation in the toolholder is 11°

· KGBF/KGBFS Holder with GBF Insert Maximum Machining Diameter

- 0.118" (3mm) groove depth is available on workpiece diameters up to $\phi 2.008"$ (51mm)
 - 0.106" (2.7mm) groove depth is available on workpiece diameters up to $\phi 3.937"$ (100mm)
 - 0.098" (2.5mm) groove depth is available on workpiece diameters up to $\phi 7.874"$ (200mm)
- The workpiece will interfere with the holder at maximum cutting diameter or larger.

· Grooving Depth : 0.118" (3mm)

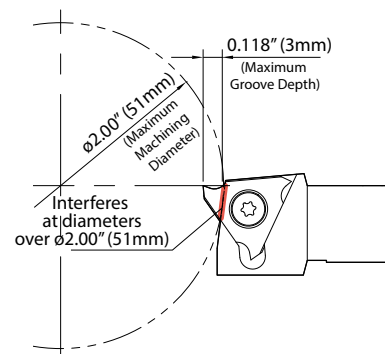

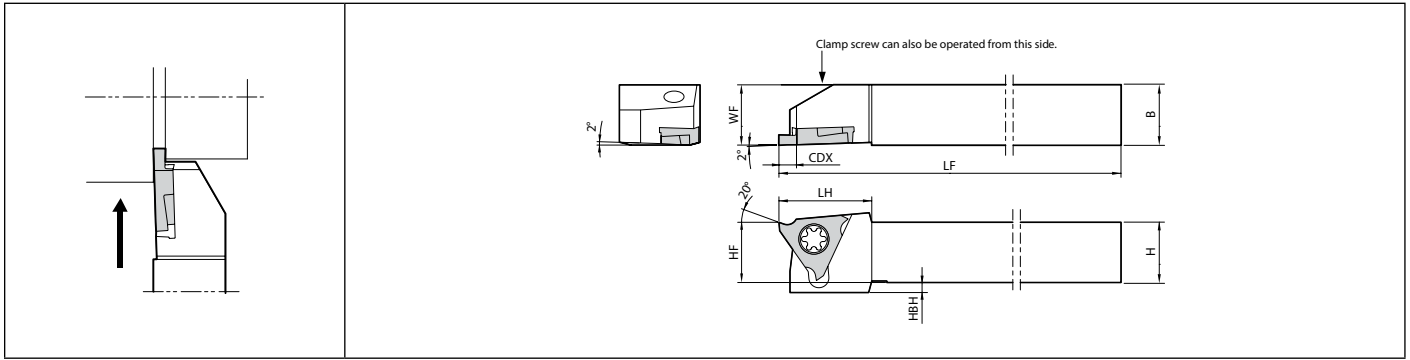

GBA32 (PCD) Recommended Cutting Conditions

Workpiece Material	Recommended Insert Grade (Cutting Speed Vc: sfm)	[1] Grooving Feed Rate (ipr) [2] Traversing Feed Rate (ipr) [3] Max D.O.C. for Traversing (in)
	PCD	
	KPD001 (KPD010)	
		GBA32R 125 - 200 (-010)
Aluminum Alloy	★ 490 - 6,560	[1] 0.0020 - 0.0059 [2] 0.0020 - 0.0059 [3] MAX. 0.0197
Brass	★ 660 - 2,620	[1] 0.0020 - 0.0059 [2] 0.0020 - 0.0059 [3] MAX. 0.0197



Right-hand shown | Right-hand Insert for Right-hand Toolholder, Left-hand Insert for Left-hand Toolholder.

Toolholder Dimensions

Unit	Part Number	Std. Item		Dimensions								Spare Parts		Applicable Inserts ➔ Page 6-8
		R	L	CDX	H	B	LH	HF	HBH	LF	WF			
Inch	KGBF% 6-3JXF	●	●	0.118	0.375	0.375	0.728	0.375	0.157	4.750	0.375	SB-4070TRW	FT-8	GBF32%
	8-3JXF	●	●		0.500	0.500		0.500	0.079		0.500			
	10-3JXF	●	●		0.625	0.625		0.625	-		0.625			
mm	KGBF% 1010JX-16F	●	●	3	10	10	18.5	10	4	120	10	SB-4070TRW	FT-8	GBF32%
	1212JX-16F	●	●		12	12		12	2		12			
	1616JX-16F	●	●		16	16		16	-		16			
	2020JX-16F	●	●		20	20		20	-		20			

CDX shows the distance from the toolholder to the cutting edge. Available Groove Depth : "CDX" of Insert.

● : Standard Item

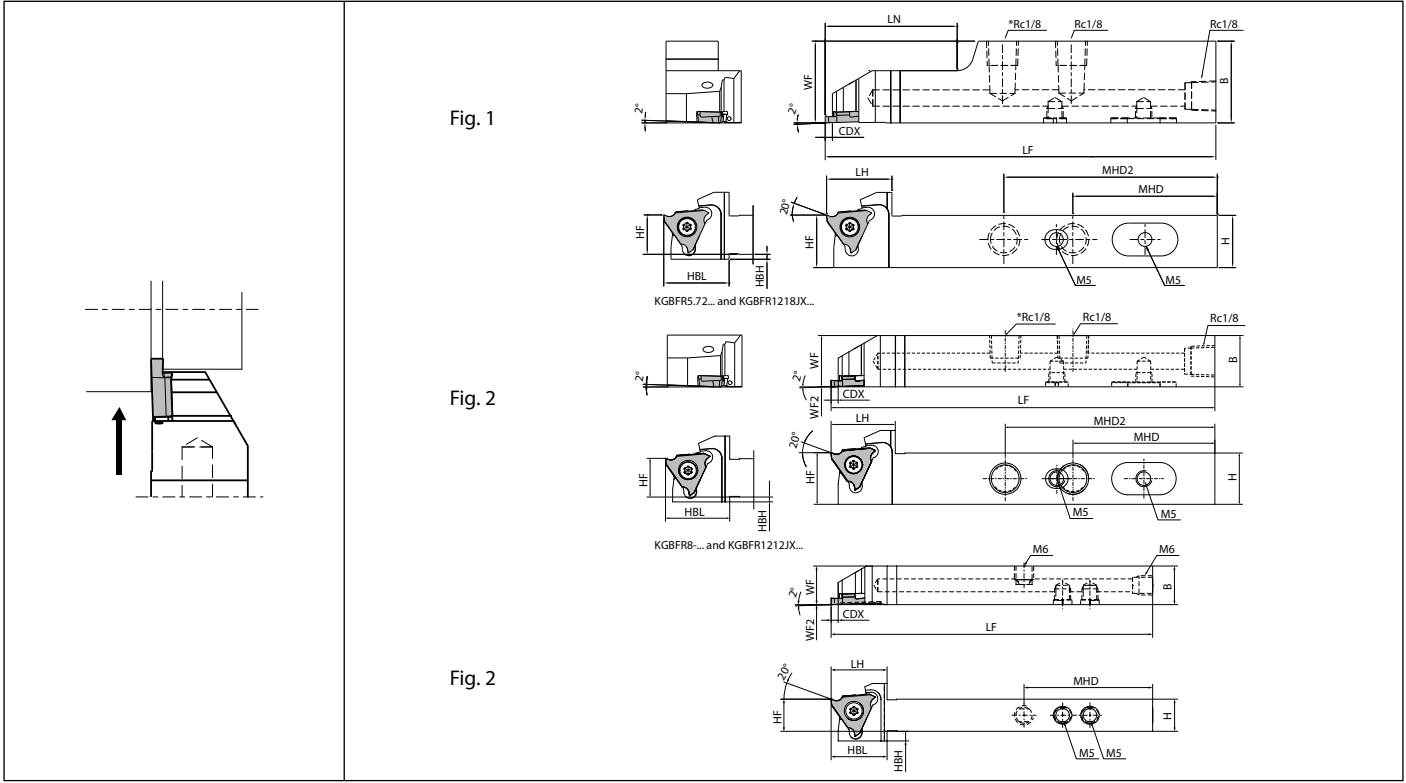

Right-hand shown | Right-hand Insert for Right-hand Toolholder.
 KGBFR5.72-..., KGBFR8-... : 2-Rc1/8
 KGBFR1218JX..., KGBFR1212JX... : 2-Rc1/8

Toolholder Dimensions

Unit	Part Number	Std. Item	Dimensions													Fig.	Spare Parts				Applicable Inserts Page 6-7
			R	CDX	H	B	LH	MHD	MHD2	HF	HBH	HBL	LF	LN	WF		Plug	Plug	Screw	Wrench	
Inch	KGBFR 3.81-5-16HFJCTM	●		0.375	0.472	0.685	1.575	-	0.375	0.118	0.685	3.937	-	0.472	3	HS6X6LP	HSSX4LP	SB-4070TRW	FT-8	GBF32R	
	5.72-16FJCTM	●	0.118	0.500	0.709	0.787	2.126	-	0.500	0.059	0.787	4.750	1.110	0.500	1	GP-1	-	-	-	-	
	82.5-16FJCTM	●		0.625	1.000	0.787	1.732	2.559	0.625	-	-	4.750	-	0.625	1	GP-1	-	-	-	-	
	KGBFR 8-16FJCTM	●		0.500	0.500	0.787	2.323	-	0.500	0.059	0.787	4.750	-	0.500	2	GP-1	HSSX4LP	SB-4070TRW	FT-8	GBF32R	
	10-16FJCTM	●	0.118	0.625	0.625	0.787	1.732	2.559	0.625	-	-	4.750	-	0.625	2	GP-1	-	-	-	-	
	12-16FJCTM	●		0.750	0.750	0.787	1.732	2.559	0.750	-	-	4.750	-	0.750	2	GP-1	-	-	-	-	
mm	KGBFR 1012H-16FJCTM	●		10	12	17.4	40	-	10	3	17.4	100	-	12	3	HS6X6LP	HSSX4LP	SB-4070TRW	FT-8	GBF32R	
	1218JX-16FJCTM	●	3	12	18	20	54	-	12	1.5	20	120	28	12	1	GP-1	HSSX4LP	SB-4070TRW	FT-8	GBF32R	
	1625JX-16FJCTM	●		16	25	20	44	65	16	-	-	120	40	16	1	GP-1	-	-	-	-	
	2025JX-16FJCTM	●		20	20	20	44	65	20	-	-	120	40	20	1	GP-1	-	-	-	-	
	KGBFR 1212JX-16FJCTM	●		12	12	20	59	-	12	1.5	20	120	-	12	2	GP-1	HSSX4LP	SB-4070TRW	FT-8	GBF32R	
	1616JX-16FJCTM	●	3	16	16	20	44	65	16	-	-	120	-	16	2	GP-1	-	-	-	-	
2020JX-16FJCTM	●		20	20	20	44	65	20	-	-	120	-	20	2	GP-1	-	-	-	-		

CDX shows the distance from the toolholder to the cutting edge. Available Groove Depth : "CDX" of Insert.

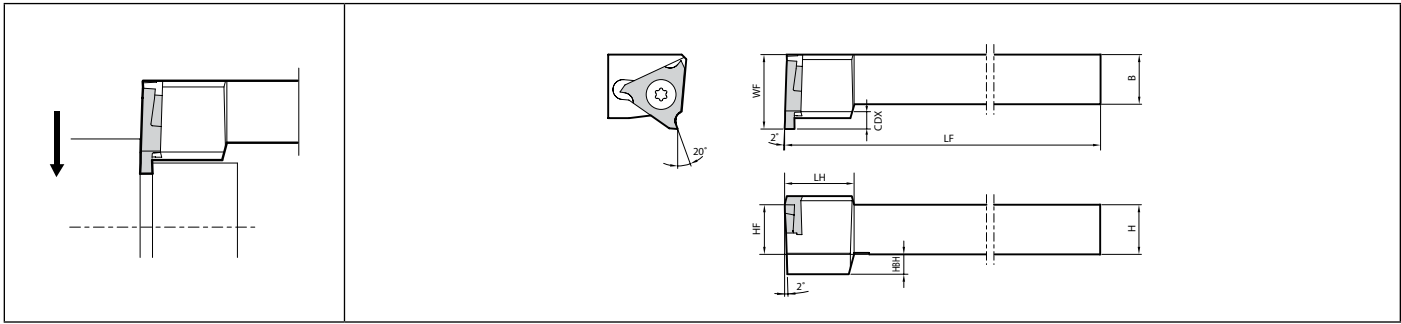

● : Standard Item

Available Piping Parts see Pages 14-15



Right-hand shown | Left-hand Insert for Right-hand Toolholder, Right-hand Insert for Left-hand Toolholder.

Toolholder Dimensions

Unit	Part Number	Std. Item		Dimensions								Spare Parts		Applicable Inserts ➡ Page 6-8
		R	L	CDX	H	B	LH	HF	HBH	LF	WF	Screw 	Wrench 	
		●	●											
mm	KGBFS% 1010JX-16	●	●	3	10	10	14	10	4	120	15	SB-4070TRW	FT-8	GBF32 ^{1/2} /R
	1212JX-16	●	●		12	12		12	2		16			
	1616JX-16	●	●		16	16		16	-		20			

CDX shows the distance from the toolholder to the cutting edge. Available Groove Depth : "CDX" of Insert.

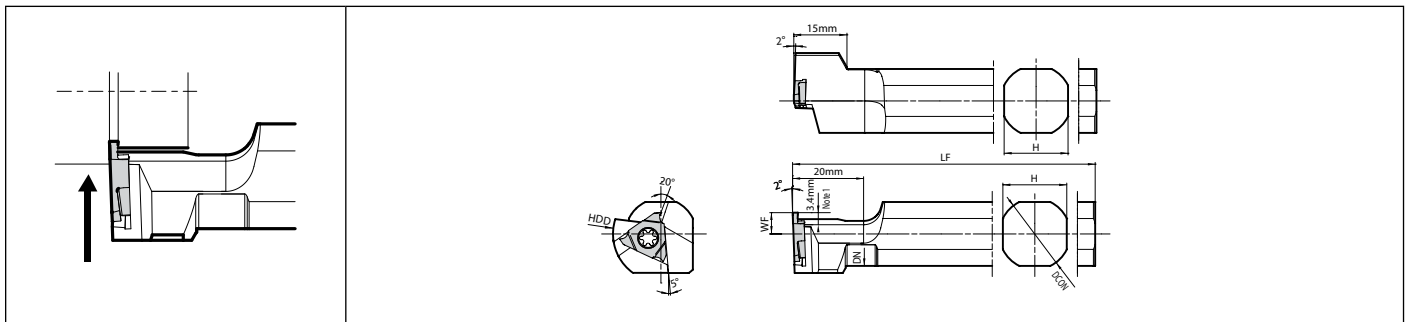

● : Standard Item

S-KGBF (Sleeve Holder)



Left-hand shown | Right-hand Insert for Left-hand Toolholder. | Note 1) CDX shows available grooving depth.

Toolholder Dimensions

Unit	Part Number	Std. Item	Dimensions							Spare Parts		Applicable Inserts ➡ Page 6-8
			L	DCON	H	DN	HDD	LF	WF	Screw 	Wrench 	
Inch	S15F- KGBFL16	●	0.625	0.591	0.591	1.063	3.346	0.236	SB-4070TRW	FT-8	GBF32R	
	S19G- KGBFL16	●										
	S19K- KGBFL16	●										
	S25K- KGBFL16	●	1.000	0.906	0.945	1.260	3.937	0.394				
mm	S12F- KGBFL16	●	20	18	19	27	80	6	SB-4070TRW	FT-8	GBF32R	
	S14H- KGBFL16	●										
	S16F- KGBFL16	●										
	S20G- KGBFL16	●										
	S20K- KGBFL16	●										
	S22K- KGBFL16	●										
	S25.0H- KGBFL16	●										

Note 1) Dimension shown is the available grooving depth of the insert (CDX)

● : Standard Item

Recommended Cutting Conditions ★ 1st Recommendation ☆ 2nd Recommendation

GBF inserts

Workpiece Material	Recommended Insert Grade (Cutting Speed Vc: sfm)			(1) Grooving Feed Rate (ipr) (2) Traversing Feed Rate (ipr) (3) Max D.O.C. for Traversing (in)				Notes
	MEGACOAT	MEGACOAT NANO	Carbide	GBF32 [℞] 025~053	GBF32 [℞] 065~095	GBF32 [℞] 100~145	GBF32 [℞] 150~300	
	PR1215	PR1535	GW15					
Carbon Steel	★ 260 - 590	☆ 230 - 530	-	(1) 0.0004 - 0.0020 (2) Not Recommended (3) Not Recommended	(1) 0.0008 - 0.0028 (2) Not Recommended (3) Not Recommended	(1) 0.0012 - 0.0031 (2) 0.0012 - 0.0024 (3) MAX. 0.0079	(1) 0.0012 - 0.0031 (2) 0.0012 - 0.0024 (3) MAX. 0.0079	Coolant
Alloy Steel	★ 260 - 590	☆ 230 - 530	-	(1) 0.0004 - 0.0016 (2) Not Recommended (3) Not Recommended	(1) 0.0008 - 0.0024 (2) Not Recommended (3) Not Recommended	(1) 0.0012 - 0.0028 (2) 0.0008 - 0.0020 (3) MAX. 0.0079	(1) 0.0012 - 0.0028 (2) 0.0008 - 0.0020 (3) MAX. 0.0079	
Stainless Steel	☆ 200 - 430	★ 160 - 390	-	(1) 0.0004 - 0.0016 (2) Not Recommended (3) Not Recommended	(1) 0.0008 - 0.0024 (2) Not Recommended (3) Not Recommended	(1) 0.0012 - 0.0028 (2) 0.0008 - 0.0020 (3) MAX. 0.0079	(1) 0.0012 - 0.0028 (2) 0.0008 - 0.0020 (3) MAX. 0.0079	
Cast Iron	-	-	★ 200 - 330	(1) 0.0004 - 0.0020 (2) Not Recommended (3) Not Recommended	(1) 0.0008 - 0.0028 (2) Not Recommended (3) Not Recommended	(1) 0.0012 - 0.0031 (2) 0.0012 - 0.0024 (3) MAX. 0.0079	(1) 0.0012 - 0.0031 (2) 0.0012 - 0.0024 (3) MAX. 0.0079	
Aluminum Alloy	-	-	★ 490 - 1,310	(1) 0.0004 - 0.0020 (2) Not Recommended (3) Not Recommended	(1) 0.0008 - 0.0028 (2) Not Recommended (3) Not Recommended	(1) 0.0012 - 0.0031 (2) 0.0012 - 0.0024 (3) MAX. 0.0079	(1) 0.0012 - 0.0031 (2) 0.0012 - 0.0024 (3) MAX. 0.0079	
Brass	-	-	★ 490 - 980	(1) 0.0004 - 0.0016 (2) Not Recommended (3) Not Recommended	(1) 0.0008 - 0.0028 (2) Not Recommended (3) Not Recommended	(1) 0.0012 - 0.0028 (2) 0.0008 - 0.0020 (3) MAX. 0.0079	(1) 0.0012 - 0.0028 (2) 0.0008 - 0.0020 (3) MAX. 0.0079	

★:1st Recommendation ☆:2nd Recommendation

GBF32...-000F inserts (RE = 0.00)

Workpiece Material	Recommended Insert Grade (Cutting Speed Vc: sfm)			(1) Grooving Feed Rate (ipr) (2) Traversing Feed Rate (ipr) (3) Max D.O.C. for Traversing (in)				Notes
	MEGACOAT	MEGACOAT NANO	Carbide	GBF32 [℞] 025 ~ 053 - 000F	GBF32 [℞] 065 ~ 095 - 000F	GBF32 [℞] 100 ~ 145 - 000F	GBF32 [℞] 150 ~ 200 - 000F	
	PR1215	PR1535	GW15					
Carbon Steel	★ 260 - 590	☆ 230 - 530	-	(1) 0.0002 - 0.0012 (2) Not Recommended (3) Not Recommended	(1) 0.0004 - 0.0016 (2) Not Recommended (3) Not Recommended	(1) 0.0004 - 0.0020 (2) 0.0004 - 0.0016 (3) MAX. 0.0079	(1) 0.0004 - 0.0020 (2) 0.0004 - 0.0016 (3) MAX. 0.0079	Coolant
Alloy Steel	★ 260 - 590	☆ 230 - 530	-	(1) 0.0002 - 0.0010 (2) Not Recommended (3) Not Recommended	(1) 0.0004 - 0.0012 (2) Not Recommended (3) Not Recommended	(1) 0.0004 - 0.0016 (2) 0.0004 - 0.0012 (3) MAX. 0.0079	(1) 0.0004 - 0.0016 (2) 0.0004 - 0.0012 (3) MAX. 0.0079	
Stainless Steel	☆ 200 - 430	★ 160 - 390	-	(1) 0.0002 - 0.0008 (2) Not Recommended (3) Not Recommended	(1) 0.0004 - 0.0010 (2) Not Recommended (3) Not Recommended	(1) 0.0004 - 0.0012 (2) 0.0004 - 0.0010 (3) MAX. 0.0079	(1) 0.0004 - 0.0012 (2) 0.0004 - 0.0010 (3) MAX. 0.0079	
Cast Iron	-	-	★ 200 - 330	(1) 0.0002 - 0.0012 (2) Not Recommended (3) Not Recommended	(1) 0.0004 - 0.0016 (2) Not Recommended (3) Not Recommended	(1) 0.0004 - 0.0020 (2) 0.0004 - 0.0016 (3) MAX. 0.0079	(1) 0.0004 - 0.0020 (2) 0.0004 - 0.0016 (3) MAX. 0.0079	
Aluminum Alloy	-	-	★ 490 - 1,310	(1) 0.0002 - 0.0012 (2) Not Recommended (3) Not Recommended	(1) 0.0004 - 0.0016 (2) Not Recommended (3) Not Recommended	(1) 0.0004 - 0.0020 (2) 0.0004 - 0.0016 (3) MAX. 0.0079	(1) 0.0004 - 0.0020 (2) 0.0004 - 0.0016 (3) MAX. 0.0079	
Brass	-	-	★ 490 - 980	(1) 0.0004 - 0.0012 (2) Not Recommended (3) Not Recommended	(1) 0.0004 - 0.0016 (2) Not Recommended (3) Not Recommended	(1) 0.0004 - 0.0020 (2) 0.0004 - 0.0016 (3) MAX. 0.0079	(1) 0.0004 - 0.0020 (2) 0.0004 - 0.0016 (3) MAX. 0.0079	

★:1st Recommendation ☆:2nd Recommendation

GBF-GL inserts

Workpiece Material	Recommended Insert Grade (Cutting Speed Vc: sfm)		(1) Grooving Feed Rate (ipr) (2) Traversing Feed Rate (ipr) (3) Max D.O.C. for Traversing (in)				Notes
	MEGACOAT	MEGACOAT NANO	GBF32R075~005GL	GBF32R095 ~ 100-005GL	GBF32R 150 - 200 (GL)	GBF32R 300 (GL)	
	PR1215	PR1535					
Carbon Steel	★ 260 - 590	☆ 230 - 530	(1) 0.0008 - 0.0028 (2) Not Recommended (3) Not Recommended	(1) 0.0012 - 0.0031 (2) 0.0012 - 0.0024 (3) MAX. 0.0079	(1) 0.0012 - 0.0031 (2) 0.0012 - 0.0024 (3) MAX. 0.0079	(1) 0.0016 - 0.0039 (2) 0.0016 - 0.0031 (3) MAX. 0.0197	Coolant
Alloy Steel	★ 260 - 590	☆ 230 - 530	(1) 0.0008 - 0.0024 (2) Not Recommended (3) Not Recommended	(1) 0.0012 - 0.0028 (2) 0.0012 - 0.0024 (3) MAX. 0.0079	(1) 0.0012 - 0.0028 (2) 0.0012 - 0.0024 (3) MAX. 0.0079	(1) 0.0016 - 0.0035 (2) 0.0016 - 0.0031 (3) MAX. 0.0197	
Stainless Steel	☆ 200 - 430	★ 160 - 390	(1) 0.0008 - 0.0024 (2) Not Recommended (3) Not Recommended	(1) 0.0012 - 0.0028 (2) 0.0012 - 0.0024 (3) MAX. 0.0079	(1) 0.0012 - 0.0028 (2) 0.0012 - 0.0024 (3) MAX. 0.0079	(1) 0.0016 - 0.0035 (2) 0.0016 - 0.0031 (3) MAX. 0.0197	

★:1st Recommendation ☆:2nd Recommendation

Piping Parts

Coolant Piping Parts

Pipe parts will be required separately if internal coolant is used

Pump Pressure: up to 2,900 psi

Pump Pressure: up to 1,090 psi if couplers are used

Without Coupler (Pump Pressure: up to 2,900 psi)

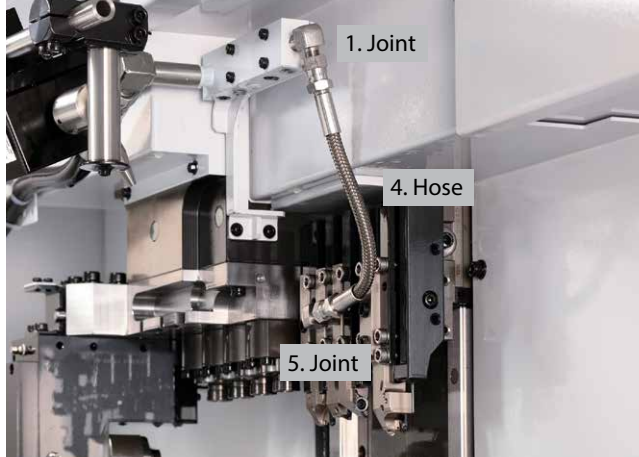

Combination Part Number (Example)

Part	Part Number
1. Joint	J-ST-R1/8-G1/8
4. Hose	HS-G1/8-G1/8-500
5. Joint	J-ST-R1/8-G1/8

Convert the thread standards on the machine's side (Rc1/4, Rc1/8, NPT1/8, etc.) to the thread standard on the hose side (G1/8) for use.
Use sealing agents such as seal tapes when installing piping parts.

With Coupler (Pump Pressure: Up to 1,090 psi)

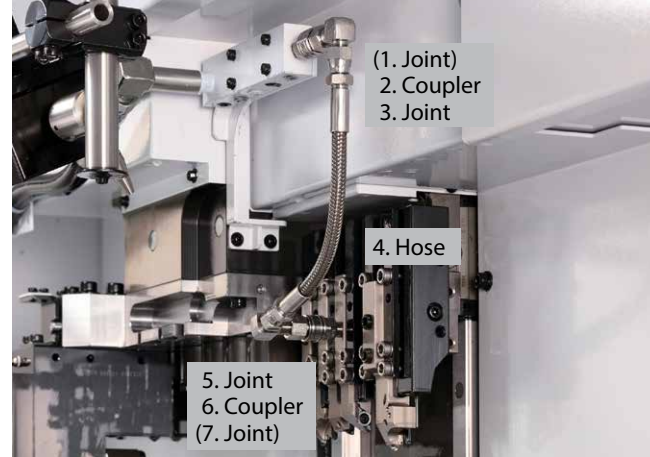

Combination Part Number (Example)

Part	Part Number
(1. Joint)	-
2. Coupler	CP-ST-R1/8, P-ST-RC1/8
3. Joint	J-AN-R1/8-G1/8
4. Hose	HS-G1/8-G1/8-200
5. Joint	J-AN-R1/8-G1/8
6. Coupler	P-ST-RC1/8, CP-ST-R1/8
(7. Joint)	-

Convert the thread standards on the machine's side (Rc1/4, Rc1/8, NPT1/8, etc.) to thread standards of the coupler (Rc1/8, etc.) or hose (G1/8) for use.
Use sealing agents such as seal tapes when installing piping parts.

Combinations

Without Coupler (Pump Pressure : Up to 2,900 psi)

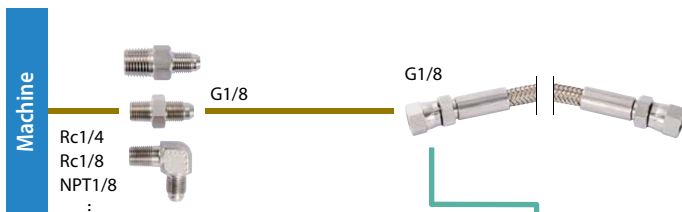

With Coupler (Pump Pressure : Up to 1,090 psi)

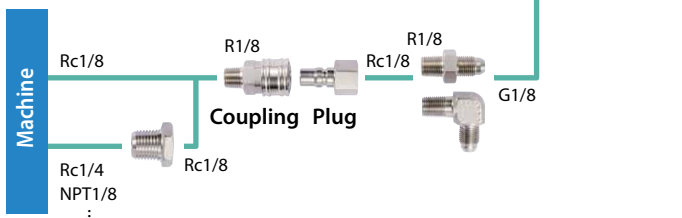

1. Joint 2. Coupler 3. Joint 4. Hose

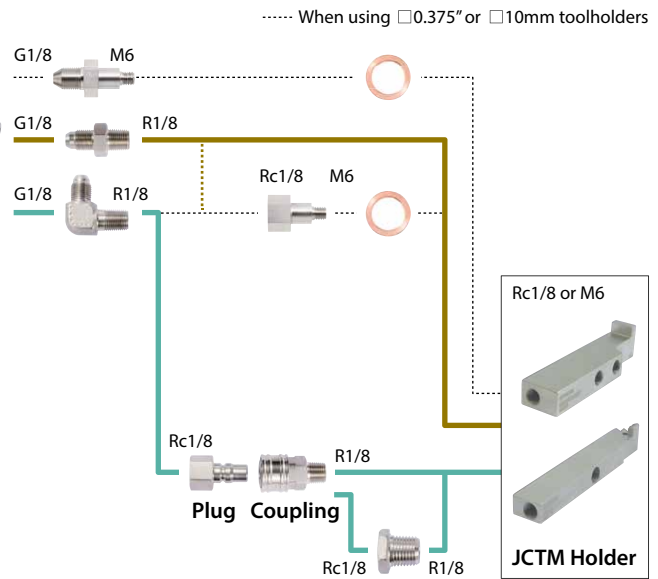





5. Joint 6. Coupler 7. Joint (Extension Joint)

Piping Parts

Piping Part Dimensions

Joint [(1)(3)(5)(7)] Pressure Resistance: up to 2,900 psi

(Unit: mm)



Shape	Part Number	Std. Item	ød1	ød2	L	L1	L2	T1	T2
	J-ST-R1/4-G1/8	●	5.5	4.0	34	13	13	R1/4	G1/8
	J-ST-NPT1/8-G1/8	●	3.5	3.5	29	10	13	NPT1/8	G1/8
	J-ST-R1/8-G1/8	●	4.0	4.0	29	10	13	R1/8	G1/8
	J-ST-R1/8-G1/8-L	●	4.0	4.0	40	20	14	R1/8	G1/8
	J-ST-M6-G1/8	●	2.5	4.0	34.2	15.2	13	M6	G1/8
	J-AN-R1/8-G1/8	●	4.0	4.0	27	14	13	R1/8	G1/8
	J-AN-R1/8-G1/8-L	●	4.0	4.0	34	20	14	R1/8	G1/8
	J-ST-R1/4-RC1/8	●	-	-	17	12	-	R1/4	Rc1/8
	J-ST-NPT1/8-RC1/8	●	3.5	-	30	10	-	NPT1/8	Rc1/8
	J-ST-R1/8-RC1/8	●	3.5	-	33	13	-	R1/8	Rc1/8
	J-ST-M6-RC1/8	●	2.5	4.0	25.2	15.2	-	M6	Rc1/8

Elbow piping (J-AN-R1/8-G1/8) is recommended.

Caution: Over-tightening may damage the pipe parts.

● : Standard Item

Coupler [(2)(6)] Pressure Resistance: up to 1,090 psi (Unit: mm)

Shape	Part Number	Std. Item
	CP-ST-R1/8	●
	P-ST-RC1/8	●

● : Standard Item

Hose (4) Pressure Resistance: up to 2,900 psi

(Unit: mm)

Shape	Part Number	Std. Item	L
	HS-G1/8-G1/8-200	●	200
	HS-G1/8-G1/8-300	●	300
	HS-G1/8-G1/8-400	●	400
	HS-G1/8-G1/8-500	●	500
	HS-G1/8-G1/8-600	●	600
	HS-G1/8-G1/8-800	●	800

● : Standard Item

1. Make sure machine door is completely closed before use of these parts.
2. Use appropriate seal for the male thread of the piping parts and make sure the connection is secure. Use plugs to seal off unused coolant holes.
3. Connect and fasten the coolant hose firmly.
4. The use of copper washers may cause leakage but will have no effect on the performance.
5. Commercial piping parts can be used if the thread standards are same. Check the pressure resistance before use.
6. Regularly changing the coolant filter is recommended.

Washer

(Unit: mm)

Shape	Part Number	Std. Item
	WS-6	●



KYOCERA Precision Tools

238 Marc Drive
Cuyahoga Falls, OH 44223
Customer Service | 800.823.7284 - Option 1
Technical Support | 800.823.7284 - Option 2



Official Website | www.kyoceraprecisiontools.com
Distributor Website | portal.kyoceraprecisiontools.com
Email | ctsales@kyocerapti.com