

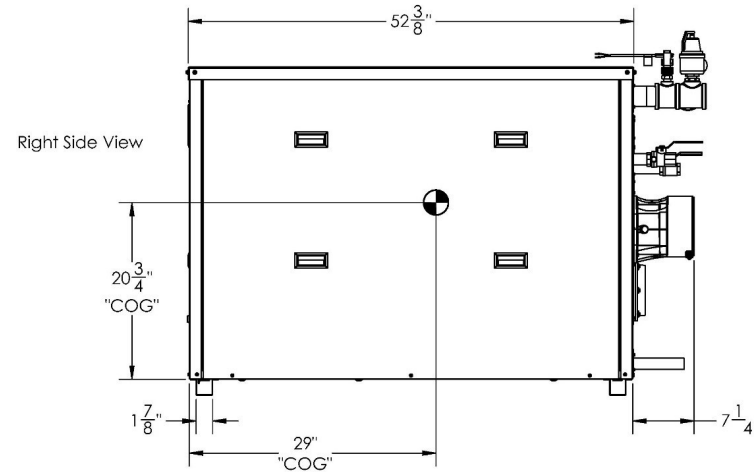

Water Heater (DHW) SUBMITTAL DATA SHEET

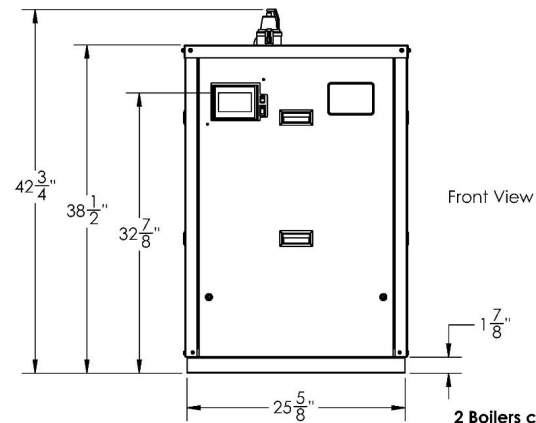

2 Boilers can be stacked vertically with included bracket kit.

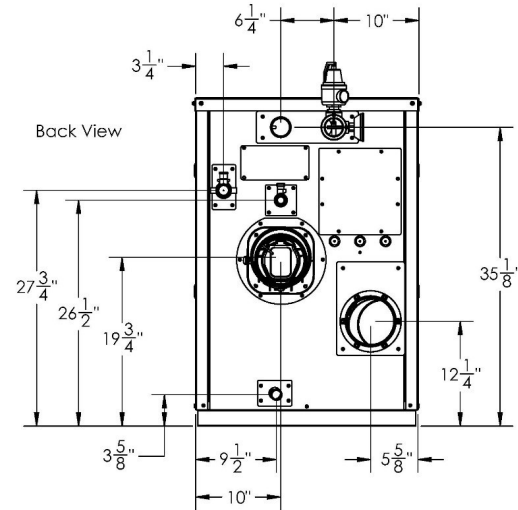
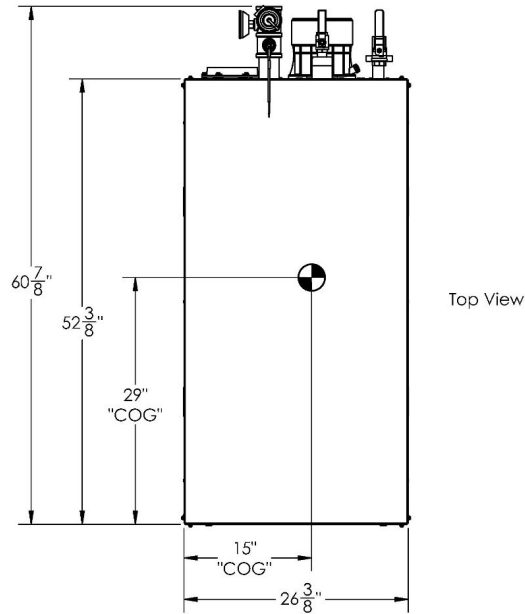

PO BOX 3244 | LANCASTER, PA 17601

AMP-800 V

INNOVATIVE EQUIPMENT FOR
HOT WATER SYSTEMS

WWW.THERMALSOLUTIONS.COM

Updated 2/24/26

ABC260201



Water Heater (DHW) SUBMITTAL DATA SHEET

RATINGS AND CAPACITIES		
Input - Low fire:	80,000	BTU/HR
Input - High Fire:	800,000	BTU/HR
Output - High Fire:	784,000	BTU/HR
Recovery Rate(per 100°F Temp Rise):	950	Gallons Per Hour (GPH)
Thermal Efficiency %:	98	
Heating Surface:	61	Sq.Ft.
Water Vol. (gal)	7	Gallons
Fuel	Natural Gas or LP	
Firing Rate:	Full Modulation	
Burner Turndown:	10:1	
Low NOx Emissions:	<10 ppm	
Inlet Gas Pressure (NG):	4" (Min.) / 14" (Max.)	
Inlet Gas Pressure (LP):	8" (Min.) / 14" (Max.)	
Approx. Shipping Weight (lb)	560	lbs
ASME Section IV (Max 160 PSIG / 210°F) Setpoint range is 60-185°F Adjustable, manual reset high limit setting of ≤ 200°F. ASME HLW stamp MAWT is 210°F for the vessel. (For max setpoint, see Setpoint range.) ETL Certified to ANSI Z21.13 / CSA 4.9 & ANSI Z21.10.3 / CSA/4.3 ETL Certified to UL 795 / CSA 3.1 & NSF / ANSI Standard 372		



FLOWS AND PRESSURE DROPS			
Delta T	Flow (GPM)	Head Loss (ft)	Water Hardness (GPG)*
20°	78	7.0	12-15
30°	52	6.7	4-12

Electrical Requirements: (Appliance Only)				
Model	Voltage	Phase	Hz	Max. Amp Draw
400	120	1	60	7
500				7
650				8
800				8
1000				8
1250-1500				10

Water Heater T&P Relief Valve Kits	
<input type="checkbox"/>	125 PSI (STANDARD)
<input type="checkbox"/>	150 PSI (OPTIONAL)

DIMENSIONS / CONNECTIONS		
Height:	38 1/2	(Note 1)
Width:	25 5/8	(Note 2)
Length:	52 3/8	(Note 3)
Water Outlet Pipe (FNPT):	2	
Water Inlet Pipe (MNPT):	2	
Vent Connection:	6	
Air Intake Connection:	6	
Condensate Drain (PVC):	1	
Drain Line Connection:	3/4	
Gas Inlet Connection (FPT):	1	

NOTES:
1. Height dimension is from floor to top of jacket.
2. Length is from jacket front to jacket rear.
3. Dimensions shown are for reference only
4. Refer to manual for gas supply piping charts



Water Heater (DHW) SUBMITTAL DATA SHEET

STANDARD EQUIPMENT

PRESSURE VESSEL DESIGN

Stainless Steel Heat Exchanger
 ASME Section IV Certified, "HLW" Stamp
 MAWP 160 PSIG & Max Temp 210°F
 Setpoint range is 60-185°F
 Adjustable, manual reset high limit setting of ≤ 200°F.
 ASME HLW stamp MAWT is 210°F for the vessel. (For max, see Setpoint range.)
 Ten Year Limited Pressure Vessel Warranty

COMBUSTION DESIGN

Stainless Steel Pre-Mix Burner
 Low NOx Emissions (< 10 ppm)
 Full Modulation, 10:1 Turndown
 Natural Gas or Propane
 4" wc (8" wc Propane) to 14" wc inlet gas pressure
 Direct Spark Ignition System
 High/Low gas pressure switches, manual reset
 Variable Speed Combustion Blower
 Blocked Vent Switch

VENTING

Category II or IV Venting
 Individual or Common (Engineered) Vent System
 Vertical or Horizontal
 3-in-1 Vent Connector: Accepts CPVC, PP or Stainless Steel
 NOTE: PVC venting requires CPVC Vent kit; Consult I&O Manual.
 Includes built-in vent gas sensor test port
 Direct Vent & Sealed or Room Air or Outdoor Ready
 Outdoor installations require the optional outdoor exhaust vent kit

APPLIANCE EQUIPMENT

Indoor / Outdoor Construction (Field Convertible)
 Stainless steel water piping suitable for boiler or domestic (potable) water applications
 Concert™ Control (24 Vac)
 High Limit Temp Control, Manual Reset
 Low water cutoff, manual reset
 Water Flow Switch
 Supply, Return & DHW Water Temperature Sensors
 Flue Gas Temperature Sensor
 Condensate trap
 Blocked Condensate Switch
 Pressure & Temperature Gauge
 ASME 125 PSI Relief Valve Standard (150 PSI Relief Valve Optional)
 NOTE: Stacking Brace Kit (PN# 111405-00 included with all 400-1500 models. Kit includes 2 braces & 8 self-drilling screws.
 NOTE: For stacking outdoor boilers, consult factory

ELECTRICAL DESIGN

<u>Models 400-500</u>	-120 VAC Only	AMP Draw: 7.0 Amps
<u>Models 650-1000</u>	-120 VAC Only	AMP Draw: 8.0 Amps
<u>Models 1250-1500:</u>	-120 VAC Only	AMP Draw: 10.0 Amps

24VAC/5VDC - Low Voltage PCB

- EMS Communications
(Dual RJ45 Jacks for Peer-To-Peer or ModBus)
- Boiler Options (Sensors)
- Pumps (Boiler, DHW, System) & Auxiliary Devices

* Flue system material shall be capable of continuous operation at 210°F or higher and shall be certified to UL 1738 – venting system for gas-burning appliances cat II, III and IV.



Water Heater (DHW) SUBMITTAL DATA SHEET

OPTIONAL EQUIPMENT

- Water Heater Pump (Circulation Pump & Pump Flange Kit)
- External High Limit Temperature Control, Manual Reset
- Condensate Neutralizer
- Supply Header Temperature Sensor:
 - Direct Immersion
 - Well Immersion (with Well)
- EMS Signal Converter Kit (Converts Energy or Building Management System 0-10v signal to 4-20mA)
- Alarm Buzzer with Silencing Switch
- PVC /CPVC Vent Kit
 - PN# 111569-01, Sizes 400-500
 - PN# 111569-02, Sizes 650-1000
 - PN# 113404-01, Sizes 1250-1500
- Outdoor Vent Kit
 - PN# 110644-01, Sizes 400-500
 - PN# 110645-01, Sizes 650-1000
 - PN# 113442-01, Sizes 1250-1500 (8")
- Universal Communications Gateway
 - BACnet, Metasys N2, Modbus
 - LonWorks
- Conductor Sequencing Panel
 - Optional Isolation Relay Board

The Conductor manages multiple condensing & non-condensing, small & large heat output, new and/or existing boilers (full modulation or on-off), and steam or hot water applications. It helps improve system efficiency by selecting and modulating the right boiler to match operating conditions. The Conductor offers a single point boiler plant Energy Management System (EMS) interface including Modbus TCP/IP, Modbus RTU RS485, BACnet/IP and BACnet MSTP standard. If Lonworks needed, add for the separate Lonworks gateway.

EXTENDED WARRANTY

- 3-Year Parts
- 5-Year Parts
- 10-Year Parts
- 5-Year Parts/Labor
- 10-Year Parts/Labor



Water Heater (DHW) SUBMITTAL DATA SHEET

CONCERT CONTROL FEATURES

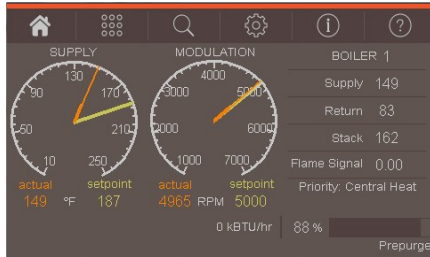

Dashboard - Color Touchscreen Display, 4"

- Intuitive Icon Navigation
- "Quick" Setup Menus
- *Real Time BTU/H Display

Two (2) Temperature Demand Inputs

- Outdoor Air Reset Curve for Each Input
- Time of Day Setback Capability
(Envirocom Thermostat must be installed)

Three (3) Pump Control

- Boiler Pump With On/Off or Variable Speed Control
- Domestic Hot Water (DHW) Pump
- System Pump
- Alternative Control to Combustion
 - Air Damper or Standby Loss Damper
- Pump Overrun for Heat Dissipation
- Pump Exercise
- Pump Rotor Seizing Protection

Peer-to-Peer Boiler Communications

- Multiple Size Boiler Sequencing Up to 8 Units
- *Two (2) Boiler Start/Stop Trigger
- Lead Boiler Automatic Rotation

Energy Management System (EMS) Interface

- *Firing Rate and Water Temperature Based
 - Algorithms for Multiple Boilers; loss of EMS signal defaults to local boiler settings
- 420mAdc Input/Output (010Vdc Optional Converter)
- ModBus Input/Output (BACnet or LonWorks Optional Gateway)
- Simultaneous Interface with Peer-to-Peer

USB Data Port Transfer

- Upload Settings Between Boilers
- Download Parameters for Troubleshooting
- Import Data into .CRV Formatted Files for Performance Analysis

* Unique to Concert

Energy Efficiency Enhancer

- AntiCycling Technology
- Multiplier boiler base load common rate
- Outdoor Air Temperature Reset Curve
- Warm Weather Shutdown
- Boost Temperature & Time
- Ramp Delay
- OverTemperature Safeguarding

Self-Guiding Diagnostics

- Identifies Fault
- Describes Possible Problems
- Provides Corrective Actions
- Time/Date Stamp on Alarms and Lockouts

Unmatched Archives

- Historical Trends Collects Up to 4 months Data
- Event History Up to 3000 Alarms, Lockouts and Cycle & Run Times
- Alarm Limit String Faults, Holds, Lockouts and Others
- Cycle & Run Time Boilers & Pumps
- Resettable (Lockouts/Alarms/Cycles & Run Time)

Domestic Hot Water Priority

- DHW Tank Piped With Priority in the Boiler Loop
- DHW Tank Piped as a Zone in the System With the Pumps Controlled by the Concert Control
- DHW Modulation Limiting
- Status Screens
- Sensor Monitoring and Control

Other Features

- Factory Default Settings
 - Three Level Password Security
 - Frost Protection
- Contractor Contacts (Up to 3)
- Low Water Flow Safety Control & Indication
- Proportional Integral Derivative (PID) Parameters for Central Heat, DHS, Sequencer and Fan

Boiler Connect Compatible

Requires one (1) Boiler Connect Bluetooth Adapter Kit (PN# 113329-01) per install or cascade)



Water Heater (DHW) SUBMITTAL DATA SHEET

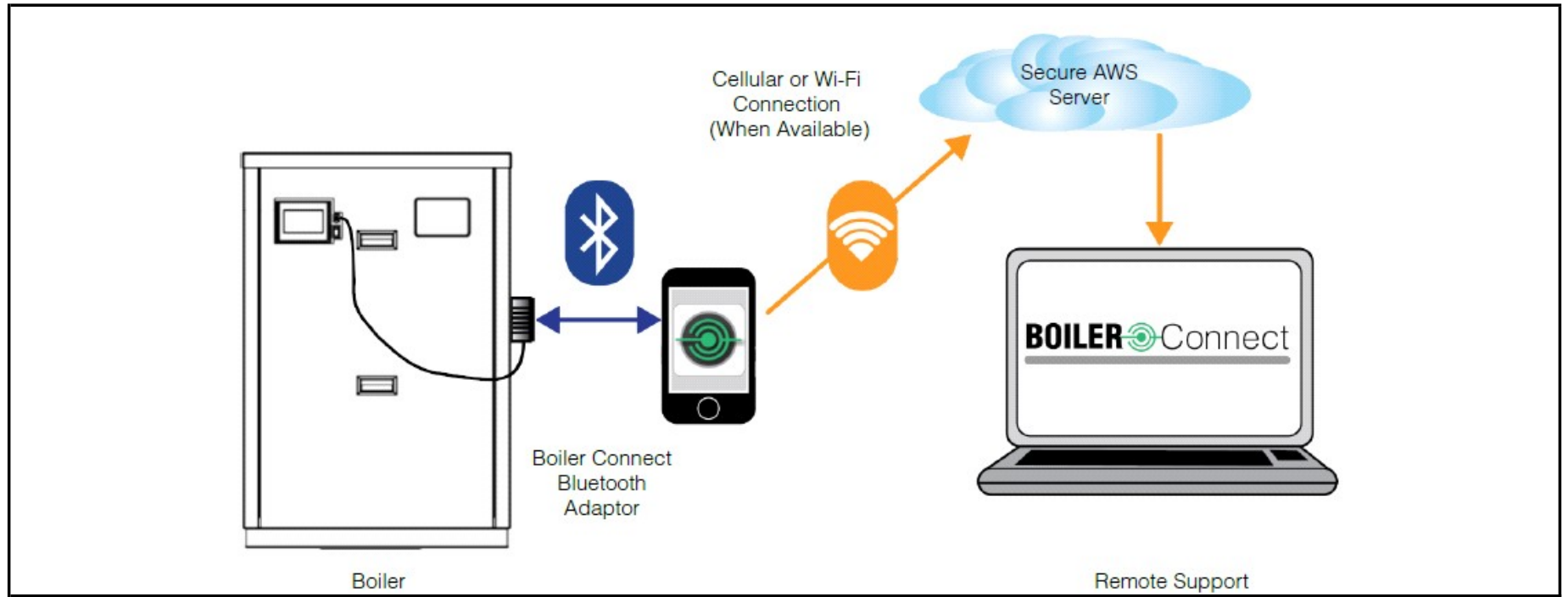

BOILER Connect

BOILER CONNECT FEATURES

- Bluetooth adapter connects to the Boiler Connect App
- English or Spanish language
- Start-up, Troubleshooting Tips and Service Wizards
- Data logs, Service and Status Reports sent to the cloud
- Live Data Sharing (Cellular Service Required) with Technical Service Representative