

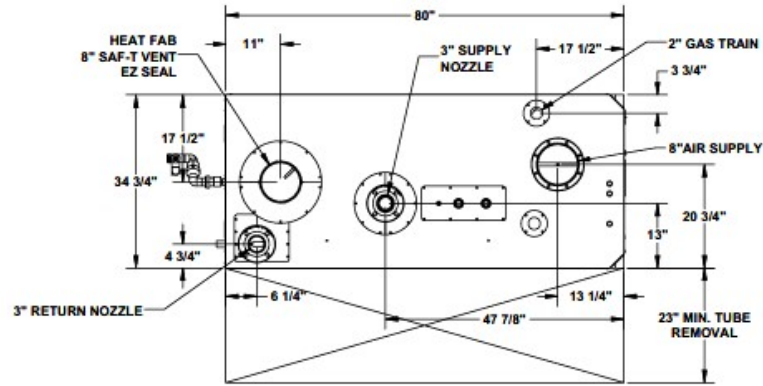

Boiler SUBMITTAL DATA SHEET

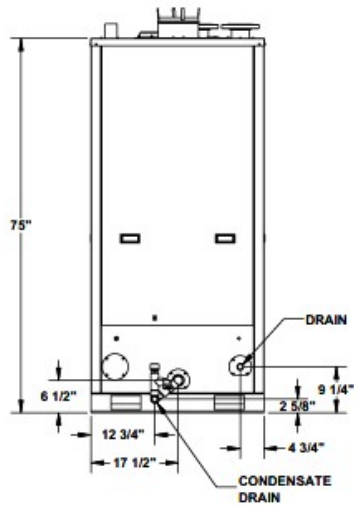

TOP VIEW



REAR VIEW

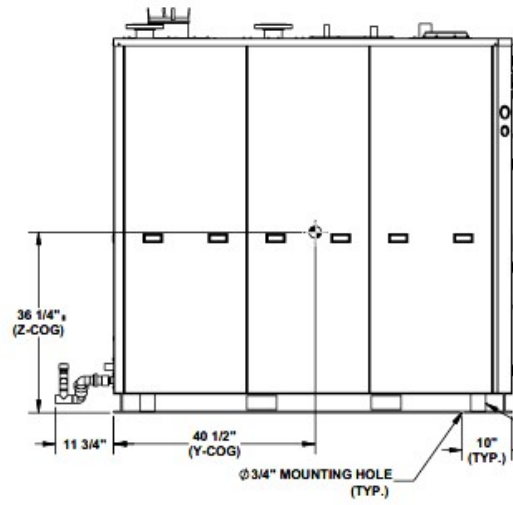

LEFT SIDE VIEW

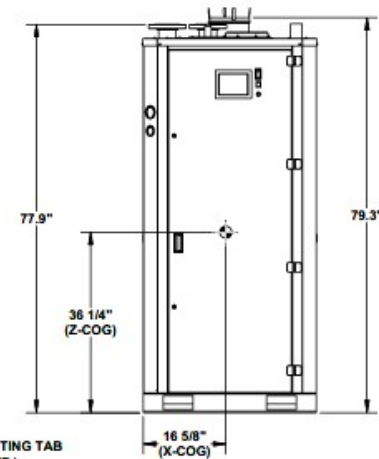

FRONT VIEW



PO BOX 3244 | LANCASTER, PA 17601

ARCTIC-2000

INNOVATIVE EQUIPMENT FOR
HOT WATER SYSTEMS

WWW.THERMALSOLUTIONS.COM



Updated 4/10/2026

ARCF260402



Boiler SUBMITTAL DATA SHEET



RATINGS AND CAPACITIES		
Input - Low fire:	400,000	BTU/HR
Input - High Fire:	1,999,000	BTU/HR
Output - High Fire:	1,899,000	BTU/HR
Boiler Horsepower:	57	BHP
Thermal Efficiency %:	95	
Combustion Efficiency %:	94	
Water Vol. (gal):	27	Gallons
Fuel:	Natural Gas ONLY	
Firing Rate:	Full Modulation	
Burner Turndown:	5:1	
Low NOx Emissions:	Capable, Consult Factory	
Inlet Gas Pressure (NG):	4" (Min.) / 14" (Max.)	
Minimum Flow Rate:*	34 gpm	0.52 Δ P (ft)
Maximum Flow Rate *	143 gpm	9.2 Δ P (ft)
<small>Note: Not for sizing constant volume pump. 1000-3000 models will force modulation at delta of 89°F, recycle at 95°F, and lock out at 100°F.</small>		
Approx. Shipping Weight (lb):	2,020	lbs.
ASME Section IV (Max 160 PSIG / 210°F)  Setpoint range is 60-185°F Adjustable, manual reset high limit setting of ≤ 200°F. ASME H stamp MAWT is 210°F for the vessel. (For max setpoint, see Setpoint range.) ETL Certified to ANSI Z21.13 / CSA 4.9  ETL Certified to UL 795 / CSA 3.1		

DIMENSIONS / CONNECTIONS		
Height:	75"	(Note 1)
Width:	35"	(Note 2)
Length:	80"	(Note 3)
Water Outlet Pipe:	3" Flange	
Water Inlet Pipe:	3" Flange	
Vent Connection:	8"	
Air Intake Connection:	8"	
Condensate Drain (PVC):	1"	
Drain Line Connection:	1"	
Gas Inlet Connection (FPT):	2"	

FLOWS AND PRESSURE DROPS					
Delta T	Flow (GPM)	Head Loss (ft)			
*85°F Δ T (Min. Flow)	45	0.9			
80°F Δ T	48	1.0			
70°F Δ T	54	1.3			
60°F Δ T	63	1.8			
50°F Δ T	76	2.6			
45°F Δ T	84	3.2			
40°F Δ T	95	4.1			
35°F Δ T	109	5.3			
30°F Δ T	127	7.2			
25°F Δ T	152	10.4			
*20°F Δ T (Max. Flow)	190	16.3			
Electrical Requirements: (Appliance Only)					
Model	Voltage	FLA	CCA	MHP	MA
1000	120/1/60	6.6 FLA	2.6 CCA	0.46 MHP	4 MA
	208-240/1/60	6.9 FLA	2.6 CCA	1.1 MHP	10.5 MA
2000-3000	120/1/60	15.6 FLA	2.6 CCA	1.5 MHP	13 MA
	208-240/1/60	8.3 FLA	2.6 CCA	1.5 MHP	5.7 MA
	208-240/3/60	9.5 FLA	2.6 CCA	3 MHP	6.9 MA
3500-4000	480/3/60	5.25 FLA	1.25 CCA	3.2 MHP	4 MA
	208-240/3/60	10.5 FLA	2.6 CCA	3 MHP	6.9 MA
4500-6000	480/3/60	5.25 FLA	1.25 CCA	3.2 MHP	4 MA
	208-240/3/60	26.6 FLA	2.6 CCA	10.7 MHP	24 MA
	480/3/60	14.25 FLA	1.25 CCA	10.7 MHP	13 MA

NOTES:
1. Height dimension is from floor to top of jacket.
2. Length is from jacket front to jacket rear.
3. Dimensions shown are for reference only
4. Refer to manual for gas supply piping charts



Boiler SUBMITTAL DATA SHEET



STANDARD EQUIPMENT

PRESSURE VESSEL DESIGN

ASME Stainless Steel Flexible Water Tube Heat Exchanger

Field-replaceable Stainless Steel Water Tubes

MAWP 160 PSIG & Max Temp 210°F

Setpoint range is 60-185°F

Adjustable, manual reset high limit setting of ≤ 200°F.

ASME H stamp MAWT is 210°F for the vessel. (For max setpoint, see Setpoint range.)

Ten Year Pressure Vessel Warranty; Lifetime Thermal Shock Warranty

COMBUSTION DESIGN

Stainless Steel Mesh Pre-Mix Burner

Modulating Gas Valve

Variable Speed Combustion Blower

Direct Spark Ignition / UV Scanner

Full Modulation, 5:1 Turndown

4" - 14" inlet gas pressure

Natural gas only

Blocked Vent Switch

CSD-1 Compliant Gas Train

High/Low gas pressure switches, manual

Air Flow Proving Switch

VENTING

Category IV Individual Venting

Category II Common Venting with Engineered Vent System

Polypropylene & Stainless Steel Acceptable* Material

Ducted or Room Combustion Air

BOILER EQUIPMENT

Concert™ Control (24 Vac)

Water Flow Switch

High Limit Temp Control, Manual Reset

Condensate Trap

Low water cutoff, manual reset

Blocked Condensate Switch

Supply & Return Water Temperature Sensors

Pressure & Temperature Gauge

Flue Gas Temperature Sensor

ASME Relief Valve: (Available: 30, 50, 60, 75, 100, 125, or 150 PSIG)

ELECTRICAL DESIGN

Model 1000:

120/1/60

Model 1500:

120/1/60

208-240/1/60

Models 2000-3000:

120/1/60

208-240/1/60

208-240/3/60

480/3/60

Models 3500-4000:

208-240/3/60

480/3/60

Models 4500-6000

208-240/3/60

480/3/60

**Flue system material shall be capable of continuous operation at 230°F or higher, have the same corrosion resistance to flue gas condensation as AL29-4C and shall be certified to UL 1738 – venting system for gas-burning appliances cat II, III and IV.*



Boiler SUBMITTAL DATA SHEET



OPTIONAL EQUIPMENT

- Hydronic Kit (Boiler Circulation Pump selected for 30° Δ T with Primary / Secondary Piping, Pump Flange Kit and Condensate Neutralizer)
- External High Limit Temperature Control, Adjustable Manual Reset, 200°F
- Condensate Neutralizer
- Supply Header Temperature Sensor [10K NTC]: Direct Immersion Well Immersion (with Well) [RECOMMENDED]
- Outdoor Air Temperature Sensor (Wired) [10K NTC]
- EMS Signal Converter Kit (Converts Energy or Building Management System 0-10v signal to 4-20mA)
- Motorized Isolation Valves for Variable Primary Piping (Quick reacting, drive open / drive closed)
- Alarm Buzzer with Silencing Switch
- Gas Valve Proof of Closure (POC)
- Grooved to Flange Adapter (Model 1000 ONLY)
- Universal Communications Gateway (BACnet, Metasys, Modbus or Lonworks)
- Tube Replacement Tools
- Reverse Construction available (Sizes 1500-3000)
- Knockdown Configuration: KD-1 - Ships with jacket, flue collector/heat exchanger and base in separate cartons. (Sizes 1500-6000)
- Knockdown Configuration: KD-2 - Ships with jacket, flue collector, tubes, burner, stack, lower tube rail, and base in separate cartons. (Sizes 1500-6000)
- Conductor Sequencing Panel Optional Isolation Relay Board (for use with Conductor only)

Conductor allows integration of non-Concert controlled appliances with Concert-controlled appliances to allow seamless boiler plant integration. It manages up to four (4) hard-wired appliances, steam or hot water. It helps improve system efficiency by selecting and modulating the right boiler to match operating conditions. It also offers a single point boiler plant Energy Management System (EMS) interface including Modbus TCP/IP, Modbus RTU RS485, BACnet/IP and BACnet MSTP standard. If Lonworks needed, add for the separate Lonworks gateway. (If all boilers are Concert-controlled, this is NOT needed.)

EXTENDED WARRANTY

- 3-Year Parts
- 5-Year Parts
- 10-Year Parts
- 5-Year Parts/Labor
- 10-Year Parts/Labor



Boiler SUBMITTAL DATA SHEET



CONCERT CONTROL FEATURES



Dashboard - Color Touchscreen Display, 4"

- Intuitive Icon Navigation
- "Quick" Setup Menus
- *Real Time BTU/H Display

Three (3) Pump Control

- Boiler Pump With On/Off or Variable Speed Control
- Domestic Hot Water (DHW) Pump
- System Pump
- Alternative Control to Combustion
 - Air Damper or Standby Loss Damper
- Pump Overrun for Heat Dissipation
- Pump Exercise

Peer-to-Peer Boiler Communications

- Multiple Size Boiler Sequencing Up to 8 Units
- *Two (2) Boiler Start/Stop Trigger
- Lead Boiler Automatic Rotation

Energy Management System (EMS) Interface

- *Firing Rate and Water Temperature Based
 - Algorithms for Multiple Boilers; loss of EMS signal defaults to local boiler settings
- 420mAdc Input/Output (010Vdc Optional Converter)
- ModBus Input/Output (BACnet or LonWorks Optional Gateway)
- Simultaneous Interface with Peer-to-Peer

USB Data Port Transfer

- Upload Settings Between Boilers
- Download Parameters for Troubleshooting
- Import Data into .CRV Formatted Files for Performance Analysis

Energy Efficiency Enhancer

- AntiCycling Technology
- Adjustable boiler base load common rate
- Outdoor Air Temperature Reset Curve
- Warm Weather Shutdown
- Boost Temperature & Time
- Ramp Delay
- OverTemperature Safeguarding

Self-Guiding Diagnostics

- Identifies Fault
- Describes Possible Problems
- Provides Corrective Actions
- Time/Date Stamp on Alarms and Lockouts

Unmatched Archives

- Historical Trends Collects Up to 4 months Data
- Event History Up to 3000 Alarms, Lockouts and Cycle & Run Times
- Alarm Limit String Faults, Holds, Lockouts and Others
- Cycle & Run Time Boilers & Pumps
- Resettable (Lockouts/Alarms/Cycles & Run Time)

Domestic Hot Water Priority

- DHW Tank Piped With Priority in the Boiler Loop
- DHW Tank Piped as a Zone in the System With
 - the Pumps Controlled by the Concert Control
- DHW Modulation Limiting
- Status Screens
- Sensor Monitoring and Control

Other Features

- Factory Default Settings
 - Three Level Password Security
 - Frost Protection
- Contractor Contacts (Up to 3)
- Low Water Flow Control & Identification
- Proportional Integral Derivative (PID) Parameter for Central HEAT, DHS, Sequencer and Fan

* Unique to Concert