

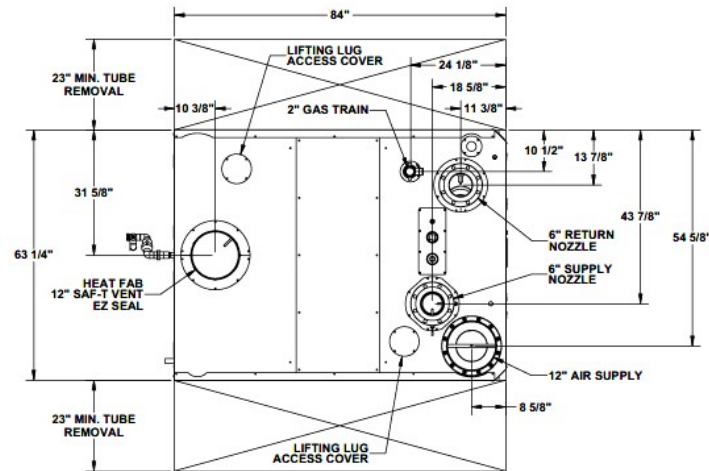

# Boiler SUBMITTAL DATA SHEET

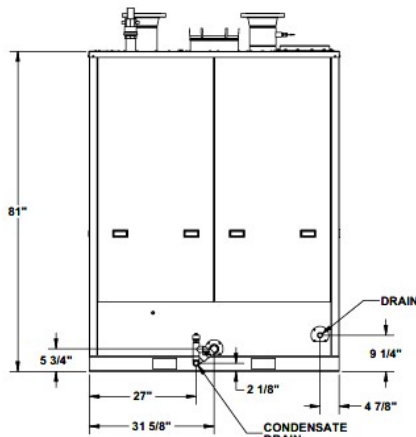

TOP VIEW



REAR VIEW

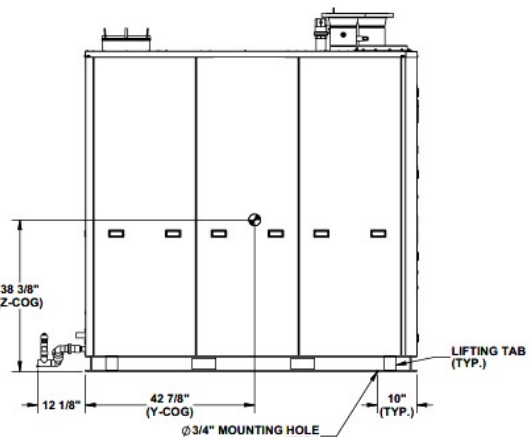

LEFT SIDE VIEW

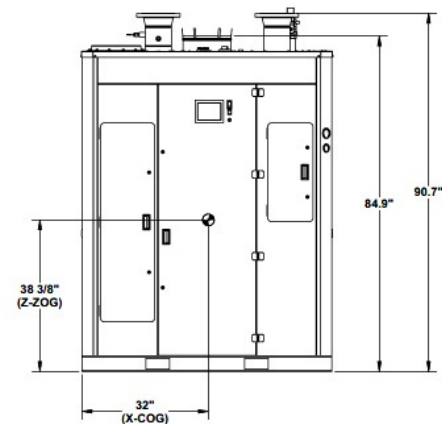

FRONT VIEW



PO BOX 3244 | LANCASTER, PA 17601

## ARCTIC-3500

INNOVATIVE EQUIPMENT FOR  
HOT WATER SYSTEMS

[WWW.THERMALSOLUTIONS.COM](http://WWW.THERMALSOLUTIONS.COM)

Updated 4/10/2026

ARCF260402



# Boiler SUBMITTAL DATA SHEET



RATINGS AND CAPACITIES		
Input - Low fire:	<b>875,000</b>	BTU/HR
Input - High Fire:	<b>3,500,000</b>	BTU/HR
Output - High Fire:	<b>3,290,000</b>	BTU/HR
Boiler Horsepower:	<b>98</b>	BHP
Thermal Efficiency %:	<b>95</b>	
Combustion Efficiency %:	<b>94</b>	
Water Vol. (gal):	<b>56</b>	Gallons
Fuel:	<b>Natural Gas ONLY</b>	
Firing Rate:	<b>Full Modulation</b>	
Burner Turndown:	<b>4:1</b>	
Low NOx Emissions:	<b>Capable, Consult Factory</b>	
Inlet Gas Pressure (NG):	<b>7" (Min.) / 14" (Max.)</b>	
Minimum Flow Rate*:	<b>102 gpm</b>	<b>1.05 Δ P (ft)</b>
Maximum Flow Rate*:	<b>333 gpm</b>	<b>11.33 Δ P (ft)</b>
<small>Note: Not for sizing constant volume pump. 3500-6000 models will force modulation at delta of 69°F, recycle at 75°F, and lock out at 80°F.</small>		
Approx. Shipping Weight (lb):	<b>4,500</b>	lbs.
ASME Section IV (Max 160 PSIG / 210°F) Setpoint range is 60-185°F Adjustable, manual reset high limit setting of ≤ 200°F. ASME H stamp MAWT is 210°F for the vessel. (For max setpoint, see Setpoint range.) ETL Certified to ANSI Z21.13 / CSA 4.9 ETL Certified to UL 795 / CSA 3.1		

FLOWS AND PRESSURE DROPS*		
Delta T	Flow (GPM)	Head Loss (ft)
*65°F Δ T (Min. Flow)	<b>102</b>	<b>1.1</b>
60°F Δ T	<b>111</b>	<b>1.2</b>
50°F Δ T	<b>133</b>	<b>1.5</b>
45°F Δ T	<b>148</b>	<b>2.1</b>
40°F Δ T	<b>166</b>	<b>2.6</b>
35°F Δ T	<b>190</b>	<b>3.3</b>
30°F Δ T	<b>222</b>	<b>4.6</b>
25°F Δ T	<b>190</b>	<b>3.3</b>
*20°F Δ T (Max. Flow)	<b>222</b>	<b>4.6</b>

Electrical Requirements: (Appliance Only)					
Model	Voltage	FLA	CCA	MHP	MA
<b>1000</b>	120/1/60	6.6 FLA	2.6 CCA	0.46 MHP	4 MA
	208-240/1/60	6.9 FLA	2.6 CCA	1.1 MHP	4.3 MA
<b>2000-3000</b>	120/1/60	15.6 FLA	2.6 CCA	1.5 MHP	13 MA
	208-240/1/60	8.3 FLA	2.6 CCA	1.5 MHP	5.7 MA
	208-240/3/60	9.5 FLA	2.6 CCA	3 MHP	6.9 MA
<b>3500-4000</b>	480/3/60	5.25 FLA	1.25 CCA	3.2 MHP	4 MA
	208-240/3/60	10.5 FLA	2.6 CCA	3 MHP	6.9 MA
<b>4500-6000</b>	480/3/60	5.25 FLA	1.25 CCA	3.2 MHP	4 MA
	208-240/3/60	26.6 FLA	2.6 CCA	10.7 MHP	24 MA
	480/3/60	14.25 FLA	1.25 CCA	10.7 MHP	13 MA

DIMENSIONS / CONNECTIONS		
Height:	<b>81"</b>	(Note 1)
Width:	<b>64"</b>	(Note 2)
Length:	<b>84"</b>	(Note 3)
Water Outlet Pipe:	<b>6" Flange</b>	
Water Inlet Pipe:	<b>6" Flange</b>	
Vent Connection:	<b>12"</b>	
Air Intake Connection:	<b>12"</b>	
Condensate Drain (PVC):	<b>1"</b>	
Drain Line Connection:	<b>1"</b>	
Gas Inlet Connection (FPT):	<b>2"</b>	

NOTES:
1. Height dimension is from floor to top of jacket.
2. Length is from jacket front to jacket rear.
3. Dimensions shown are for reference only
4. Refer to manual for gas supply piping charts



# Boiler SUBMITTAL DATA SHEET



## STANDARD EQUIPMENT

### PRESSURE VESSEL DESIGN

Stainless Steel Mesh Pre-Mix Burner  
 ASME Stainless Steel Heat Exchanger  
 MAWP 160 PSIG & Max Temp 210°F  
 Setpoint range is 60-185°F  
 Adjustable, manual reset high limit setting of ≤ 200°F.  
 ASME H stamp MAWT is 210°F for the vessel. (For max setpoint, see Setpoint range.)

Ten Year Pressure Vessel Warranty; Lifetime Thermal Shock Warranty

### COMBUSTION DESIGN

ASME Stainless Steel Heat Exchanger	Modulating Gas Valve
Stainless Steel Mesh Pre-Mix Burner	Supervised Pilot / UV Scanner
Variable Speed Combustion Blower	7" (Min.) / 14" (Max.)
Full Modulation, 4:1 Turndown	Blocked Vent Switch

Natural gas only  
 Blower Motor (Voltage Options Below)  
 High/Low gas pressure switches, manual reset  
 Direct Spark Ignition System with UV Scanner

### VENTING

Category IV Individual Venting  
 Category II Common Venting with Engineered Vent System  
 Polypropylene & Stainless Steel Acceptable \*Material  
 Ducted or Room Combustion Air Intake

### BOILER EQUIPMENT

Siemens LMV3 Burner Management & Parallel Positioning Fuel to Air System w/ (9) Programmable Points	Water Flow Switch
High Limit Temp Control, Manual Reset	Condensate Trap
Low water cutoff, manual reset	Blocked Condensate Switch
Supply & Return Water Temperature Sensors	Pressure & Temperature Gauge
ASME Relief Valve:	Flue Gas Temperature Sensor
(Available: 30, 50, 60, 75, 100, 125, or 150 PSIG)	

### ELECTRICAL DESIGN

#### Model 1000:

120/1/60

#### Model 1500:

120/1/60

208-240/1/60

#### Models 2000-3000:

120/1/60

208-240/1/60

208-240/3/60

480/3/60

#### Models 3500-4000:

208-240/3/60

480/3/60

#### Models 4500-6000

208-240/3/60

480/3/60

*\*Flue system material shall be capable of continuous operation at 230°F or higher, have the same corrosion resistance to flue gas condensation as AL29-4C and shall be certified to UL 1738 – venting system for gas-burning appliances cat II, III and IV.*



# Boiler SUBMITTAL DATA SHEET



## OPTIONAL EQUIPMENT

- Hydronic Kit (Boiler Circulation Pump selected for 30° Δ T with Primary / Secondary Piping, Pump Flange Kit and Condensate Neutralizer)
- External High Limit Temperature Control, Adjustable Manual Reset, 200°F
- Condensate Neutralizer
- Supply Header Temperature Sensor [10K NTC]:  Direct Immersion  Well Immersion (with Well)
- Outdoor Air Temperature Sensor (Wired) [10K NTC]
- Alarm Buzzer with Silencing Switch
- Motorized Isolation Valves for Variable Primary Piping (Quick reacting, drive open / drive closed)
- Universal Communications Gateway (BACnet, Metasys, Modbus or Lonworks)
- Tube Replacement Tools
- Knockdown Configuration: KD-1 - Ships with jacket, flue collector/heat exchanger and base in separate cartons. (Sizes 1500-6000)
- Knockdown Configuration: KD-2 - Ships with jacket, flue collector, tubes, burner, stack, lower tube rail, and base in separate cartons. (Sizes 1500-6000)

## EXTENDED WARRANTY

- 3-Year Parts       5-Year Parts       10-Year Parts       5-Year Parts/Labor       10-Year Parts/Labor



# Boiler SUBMITTAL DATA SHEET



## CONCERT CONTROL FEATURES



### **Dashboard - Color Touchscreen Display, 4"**

- Intuitive Icon Navigation
- "Quick" Setup Menus
- \*Real Time BTU/H Display

### **Three (3) Pump Control**

- Boiler Pump With On/Off or Variable Speed Control
- Domestic Hot Water (DHW) Pump
- System Pump
- Alternative Control to Combustion
  - Air Damper or Standby Loss Damper
- Pump Overrun for Heat Dissipation
- Pump Exercise
- Pump Rotor Seizing Protection

### **Peer-to-Peer Boiler Communications**

- Multiple Size Boiler Sequencing Up to 8 Units
- \*Two (2) Boiler Start/Stop Trigger
- Lead Boiler Automatic Rotation

### **Energy Management System (EMS) Interface**

- \*Firing Rate and Water Temperature Based Algorithms for Multiple Boilers; loss of EMS signal defaults to local boiler settings
- 4-20mAdc & 0-10 Vdc Input/Output
- ModBus Input/Output (BACnet or LonWorks Optional Gateway)
- Simultaneous Interface with Peer-to-Peer

### **USB Data Port Transfer**

- Upload Settings Between Boilers
- Download Parameters for Troubleshooting
- Import Data into .CRV Formatted Files for Performance Analysis

### **Energy Efficiency Enhancer**

- Anti-Cycling Technology
- Adjustable boiler base load common rate
- Outdoor Air Temperature Reset Curve
- Warm Weather Shutdown
- Boost Temperature & Time
- Ramp Delay
- OverTemperature Safeguarding

### **Self-Guiding Diagnostics**

- Self-Guiding Diagnostics
- Identifies Fault
- Describes Possible Problems
- Provides Corrective Actions

### **Unmatched Archives**

- Historical Trends Collects Up to 4 months Data
- Event History Up to 3000 Alarms, Lockouts and Cycle & Run Times
- Alarm Limit String Faults, Holds, Lockouts and Others
- Cycle & Run Time Boilers & Pumps
- Resettable (Lockouts/Alarms/Cycles & Run Time)

### **Domestic Hot Water Priority**

- DHW Tank Piped With Priority in the Boiler Loop
- DHW Tank Piped as a Zone in the System With the Pumps Controlled by the Concert Control
- DHW Modulation Limiting
- Status Screens
- Sensor Monitoring and Control

### **Other Features**

- Factory Default Settings
  - Three Level Password Security
  - Frost Protection
- Contractor Contacts (Up to 3)
- Low Water Flow Control & Identification
- Proportional Integral Derivative (PID) Parameter for Central HEAT, DHS, Sequencer and Fan

\* Unique to Concert