

HORIZONTAL TRANSFER SYSTEM
ATMOSPHERIC DESIGN
TRIPLEX WITH MULTI-STAGE CENTRIFUGAL PUMP

EFFECTIVE DATE: 01/09/03

REPLACES: 00/00/00

NOTES:

1. CONTROL AND PIPING CONFIGURATIONS WILL VARY DEPENDING ON JOB SPECIFICATIONS AND CONDITIONS.
2. DIMENSIONS ARE SUBJECT TO CHANGE WITHOUT NOTICE. CONSULT FACTORY FOR CERTIFIED DIMENSIONS.

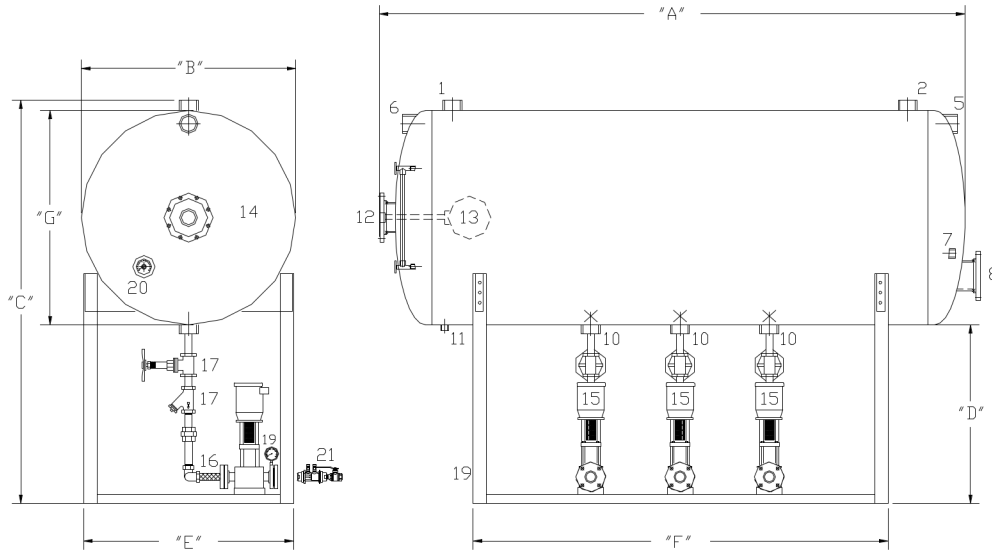

NOTE: BASE HEIGHT MAY VARY DEPENDING ON PUMP SPECIFICATIONS AND JOB CONDITIONS.

- | | | | | |
|----------------------|------------------------------|----------------------|-------------------------|-----------------------------|
| 1. VENT | 5. CONDENSATE RETURN | 9. EXTRA | 13. MAKE-UP WATER FLDAT | 17. GATE AND STRAINER VALVE |
| 2. CONDENSATE RETURN | 6. OVERFLOW | 10. PUMP SUCTION | 14. GAUGE GLASS | 18. |
| 3. | 7. STEAM SENSOR / MAG. ANODE | 11. DRAIN | 15. PUMPS | 19. |
| 4. | 8. STEAM PRE-HEATER | 12. COLD WATER INLET | 16. FLEXIBLE CONNECTOR | 20. THERMOMETER |
| | | | | 21. THROTTLING VALVE |

MODEL NUMBER	(STORAGE) GALLONS LITERS	DIMENSIONS							SHIPPING WEIGHT (PUMPS NOT INCLUDED) POUNDS KILOGRAMS
		(A) OVER-ALL LENGTH	(B) OVER-ALL WIDTH	(C) OVER-ALL HEIGHT	(D) OVER-ALL BASE HEIGHT	(E) OVER-ALL BASE WIDTH	(F) OVER-ALL BASE LENGTH	(G) TANK DIAMETER	
HTS-**-60-60*	60 72	52 132	22 56	50-1/2 128	27-1/2 70	22 56	36-1/2 93	22 56	375 171
HTS-**-100-100*	100 120	64 163	24 61	61-1/2 156	35-1/2 90	24 61	48-1/2 123	24 61	500 227
HTS-**-200-200-*	200 240	78-1/2 199	30 77	79-1/2 202	47 119	30 77	60 152	30 76	850 264
HTS-**-250-250*	250 300	80-1/2 204	36 92	82-1/2 210	44 112	36 92	60 152	36 92	950 431
HTS-**-350-350*	350 420	82 208	42 107	82 208	37-3/4 96	42 107	60 152	42 107	1050 477
HTS-**-500-500*	500 600	106 269	42 107	82-1/2 210	37-3/4 96	42 107	66 168	42 107	1450 658
HTS-**-750-750*	750 901	108 274	48 122	90-1/2 230	39-3/4 101	48 122	66 168	48 122	1600 726
HTS-**-1000-1000*	1000 1201	135 343	48 122	90-1/2 230	40 102	48 122	93 236	48 122	2000 908

BRYAN STEAM

783 N. CHILI AVE
 PERU, INDIANA 46970

FORM NO.:

2256