



Universal Communication Gateway Reference Manual

The Universal Communication Gateway (UCG) is an external, high performance Building Automation multi-protocol gateway that is preconfigured to automatically communicate between Bryan Steam's products (hereafter called "device") connected to the UCG and automatically configures them for BACnet®MS/TP, BACnet IP, Metasys®N2 by JCI, Modbus TCP/IP or LonWorks®. All Honeywell SOLA, Siemens RWF 40/55, Siemens LMV, Honeywell RM7800 Series and the Precision Digital Trident PD765 boiler configurations and Node-ID's are selected through the UCG Web GUI Configurator for fast and easy installation. A mix of multiple devices can be used on a single UCG. It is not necessary to download any configuration files to support the required applications. The UCG is pre-loaded with tested Profiles/Configurations for the supported devices. This document provides the necessary information to facilitate installation of the UCG on BACnet MS/TP, BACnet/IP, Metasys N2 and LonWorks network.

The UCG is provided as a 10" x 12" x 6" NEMA Type 1 control panel that must be mounted and supplied with 120 VAC. Additional specifications can be found in [Section 7](#).

Important

1. **If your boiler is equipped with a Bryan Boilers Printed Circuit Board (WD-857), devices should be pre-wired. See [section 3.1.8](#).**
2. **Each boiler device Modbus settings must be configured to communicate to the UCG.**

CONTENTS

| | | |
|----------|--|-----------|
| 1 | How To Use This Manual | 7 |
| 2 | Mounting UCG | 7 |
| 2.1 | Mounting | 7 |
| 2.2 | Building Management System (BMS) Wiring | 7 |
| 2.2.1 | Modbus TCP/IP and BACnet/IP | 7 |
| 2.2.2 | BACnet MS/TP and Metasys N2..... | 8 |
| 2.2.3 | LonWorks Network | 8 |
| 3 | Connect and Setup of Boiler Devices To UCG | 8 |
| 3.1 | Wiring Devices to the UCG | 8 |
| 3.1.1 | Honeywell SOLA | 9 |
| 3.1.2 | Siemens RWF40 | 9 |
| 3.1.3 | Siemens RWF55 | 9 |
| 3.1.4 | Siemens LMV2.../LMV3... | 9 |
| 3.1.5 | Siemens LMV5..... | 10 |
| 3.1.6 | Honeywell RM7800 Series | 10 |
| 3.1.7 | Precision Digital Trident PD765 Panel Meter | 11 |
| 3.1.8 | Boilers Equipped with Bryan Steam Printed Circuit Board (WD-857) | 11 |
| 3.2 | Device Modbus RTU COM Settings | 13 |
| 3.2.1 | Honeywell Sola..... | 13 |
| 3.2.2 | Siemens RWF40 | 15 |
| 3.2.3 | Siemens RWF55 | 17 |
| 3.2.4 | Siemens LMV2.../LMV3... | 18 |
| 3.2.5 | Siemens LMV5..... | 19 |
| 3.2.6 | Honeywell RM7800 Series | 20 |
| 3.2.7 | Precision Digital Trident PD765 Panel Meter | 22 |
| 4 | Setup UCG | 23 |
| 4.1 | Devices and Point Count Availability | 23 |
| 4.2 | UCG Protocol Setup | 23 |
| 4.2.1 | Configure the DIP Switches..... | 23 |
| 4.2.2 | BACnet MSTP Setup | 24 |
| 4.2.3 | Modbus TCP/IP Setup | 25 |
| 4.2.4 | BACnet/IP Setup..... | 25 |
| 4.2.5 | Metasys N2 | 26 |
| 4.2.6 | LonWorks | 27 |
| 4.3 | Setup UCG via Web Configurator | 28 |
| 4.3.1 | Connect the PC to the ProtoNode via the Ethernet Port | 28 |
| 4.3.2 | Configure Profiles in ProtoNode’s Web Configurator | 29 |
| 4.3.3 | Set IP Address for BACnet/IP via GUI..... | 32 |

- 5 Points Lists34**
 - 5.1 Honeywell Sola Modbus RTU Mappings to BACnet, Metasys N2 and LonWorks 34
 - 5.2 Seimens RWF55 Modbus RTU Mappings to BACnet, Metasys N2 and LonWorks..... 36
 - 5.3 Siemens LMV52 Modbus RTU Mappings to BACnet, Metasys N2 and LonWorks..... 37
 - 5.4 Honeywell RM7800 Modbus RTU Mappings to BACnet, Metasys N2 and LonWorks 38
 - 5.5 Seimens LMV 36 Modbus RTU Mappings to BACnet, Metasys N2 and LonWorks 39
 - 5.6 Precision Digital Trident PD765 Modbus RTU Mappings to BACnet, Metasys N2 and LonWorks..... 40

- 6 Troubleshooting41**
 - 6.1 LED Diagnostics for communications between the UCG and devices 42
 - 6.2 Take Diagnostic Capture with the FieldServer Utilities..... 43

- 7 Specifications46**

- 8 Reference.....47**
 - 8.1 WD857 47
 - 8.2 Device RTU COM Settings..... 47
 - 8.3 Address DIP Switch Settings 48
 - 8.4 Device Log..... 55

- 9 Index.....56**

FIGURES

Figure 1 - UCG Component Description..... 6

Figure 2 - Power Connection..... 7

Figure 3 - Ethernet Connection on the ProtoNode..... 7

Figure 4 - BACnet MS/TP and Metasys N2 BMS Connection..... 8

Figure 5 - LonWorks BMS connection..... 8

Figure 6 - Honeywell S7999 Display and UCG Connection 9

Figure 7 - Siemens RWF40 and UCG Connection..... 9

Figure 8 - Siemens RWF55 and UCG Connection..... 9

Figure 9 - Siemens LMV2.../LMV3... and UCG Connection 9

Figure 10 - LMV 5... And UCG Connection 10

Figure 11 - Honeywell RM7800 with S7800 Keyboard Display..... 10

Figure 12 - RM7800 with S7810M ModBus Module 10

Figure 13 - Precision Digital Trident PD765 to UCG Connection 11

Figure 14 - Bryan Steam Communication PCB (WD-857) and Multi Boiler Connection..... 11

Figure 15 - End of Line Termination..... 12

Figure 16 - Siemens RWF55 Programing 17

Figure 17 - 7810M Address Switches and Baud Rate Jumper 20

Figure 18 – Honeywell RM7800 Display Setup Screen 21

Figure 19 - Modbus Activity on RM7800 21

Figure 20 - S Bank DIP Switches 23

Figure 21 - B Bank DIP Switches..... 23

Figure 22 - A Bank DIP Switches (MAC Address) 24

Figure 23 - A Bank DIP Switches (BACnet Address) 25

Figure 24 - LonWorks Service Pin Location..... 27

Figure 25 - Sample of Fserver.XIF File Being Generated..... 27

Figure 26 - ProtoNode Ethernet Port..... 28

Figure 27 - Web Configurator Showing the Active Profiles to Select From..... 30

Figure 28 - Web Configurator Showing a Profile Selected 30

Figure 29 - Web Configurator Showing a Completed Profile Added 31

Figure 30 - Web Configurator Showing Completed Profiles Added 31

Figure 31 - Default FS Web GUI Landing Page 32

Figure 32 - Changing IP Address via FST Web GUI..... 33

Figure 33 - Diagnostic LEDs 42

Figure 34 - WD-857 Printed Circuit Board 47

TABLES

| | |
|---|----|
| Table 1 - UCG Component Description | 6 |
| Table 2 - Modbus Registers..... | 23 |
| Table 3 - BMS Protocol Selection..... | 23 |
| Table 4 - Baud Rate | 24 |
| Table 5 Diagnostic LEDs | 42 |
| Table 6 - Specifications | 46 |

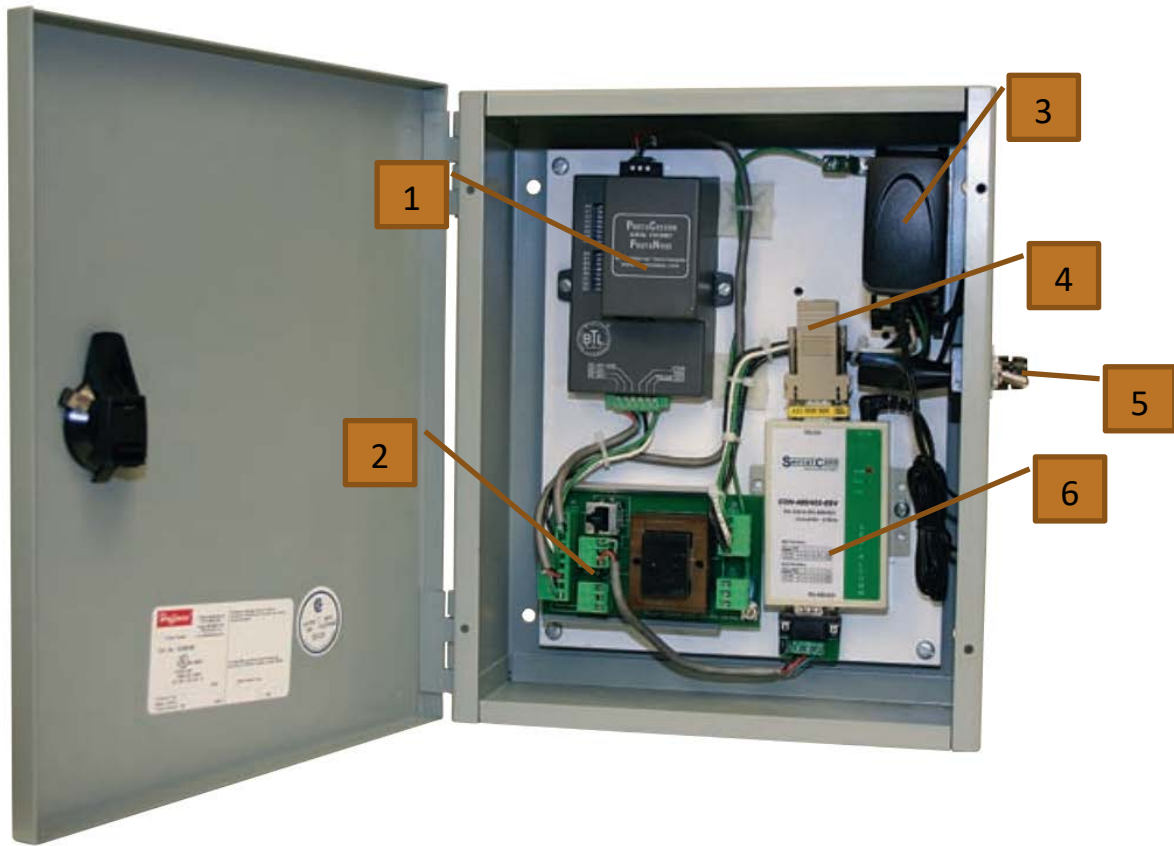

Figure 1 - UCG Component Description

| Item | Description |
|------|--|
| 1 | ProtoNode |
| 2 | UCG-PCB WD-856 |
| 3 | Power Adapter 120Vac to 9 Vdc (only for Siemens AZL) |
| 4 | RJ45 Adapter (only for Siemens AZL) |
| 5 | UCG Power Switch |
| 6 | RS232 to RS485 Converter (only for Siemens AZL) |

Table 1 - UCG Component Description

1 HOW TO USE THIS MANUAL

This manual may be used in its entirety or as a reference. **You may need to reference your device’s manual for information not covered in this UCG manual.** The three main sections are as follows:

Section 2: Mounting UCG – This section is for mounting the UCG control panel, connecting power and building management connections.

Section 3: Connect and Setup for Boiler Devices to the UCG – This section is for the connections and set-up of each device for the Modbus communication to the UCG.

Section 4: Setup for UCG – The section is for the set-up of the UCG to communicate to the devices (Modbus) and to your building management system.

All other sections are supportive of the sections above.

2 MOUNTING UCG

2.1 MOUNTING

Mount the UCG in a suitable location that is easy to access. Verify that the UCG power switch is in the “off” position. Connect J1-1(L1), J1-2(L2) and J1-3(G) of the UCG-PCB WD-856 to a 120VAC power source.

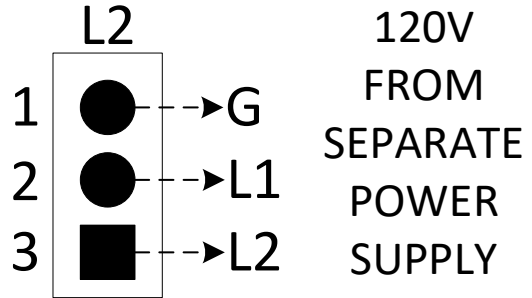

Figure 2 - Power Connection

2.2 BUILDING MANAGEMENT SYSTEM (BMS) WIRING

Building Management wiring is determined by the protocol of the BMS.

- **MODBUS TCP/IP and BACnet/IP** see [section 2.2.1](#)
- **BACNET MS/TP and METYASYS N2** see [section 2.2.2](#)
- **LONWORKS** see [section 2.2.3](#)

2.2.1 MODBUS TCP/IP AND BACNET/IP

Use Cat5 cable to connect the field BMS computer to the UCG via the Ethernet (RJ45) connection of the ProtoNode inside the UCG. See Figure 3. After BMS connection, skip to [section 3](#).



Figure 3 - Ethernet Connection on the ProtoNode

2.2.2 BACNET MS/TP AND METASYS N2

Use CAT5 twisted pair cable to connect from the field BMS computer to terminals J2-1(GND), J2-2(Data -), and J2-3(Data +) of the UCG-PCB WD-856 located inside UCG. After BMS connection, skip to [section 3](#).

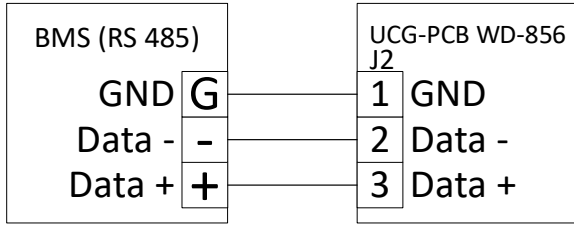

Figure 4 - BACnet MS/TP and Metasys N2 BMS Connection

2.2.3 LONWORKS NETWORK

Use CAT5 twisted pair cable to connect the field BMS computer to J2-2(-) and J2-3(+) of the UCG-PCB WD-856 located inside UCG. After BMS connection, skip to [section 3](#).

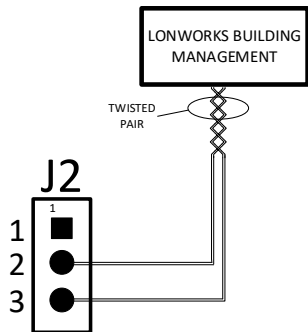

Figure 5 - LonWorks BMS connection

3 CONNECT AND SETUP OF BOILER DEVICES TO UCG

3.1 WIRING DEVICES TO THE UCG

If your boiler is equipped with a Bryan Boilers Printed Circuit Board (WD-857), see [section 3.1.8](#). Otherwise connect all devices directly to the UCG-PCB WD-856 located inside UCG. The devices on this bus can be wired in a daisy chain configuration. The order of the interconnection is not important.

- **HONEYWELL SOLA** see [section 3.1.1](#)
- **SIEMENS RWF40** see [section 3.1.2](#)
- **SIEMENS RWF55** see [section 3.1.3](#)
- **SIEMENS LMV2.../LMV3...** see [section 3.1.4](#)
- **SIEMENS LMV5...** see [section 3.1.5](#)
- **HONEYWELL RM7800 SERIES KEYBOARD DISPLAY OR MODBUS MODULE** see [section 3.1.6](#)
- **PRECISION DIGITAL TRIDENT PD765 PANEL METER** see [section 3.1.7](#)

3.1.1 HONEYWELL SOLA

Use shielded cable to connect the Honeywell system display's COM2 port to terminals J3-1(GND), J3-2(Data -), and J3-3(Data +) of the UCG-PCB WD-856 inside the UCG. Up to 8 SOLA controls can be controlled from one UCG. See Figure 6.

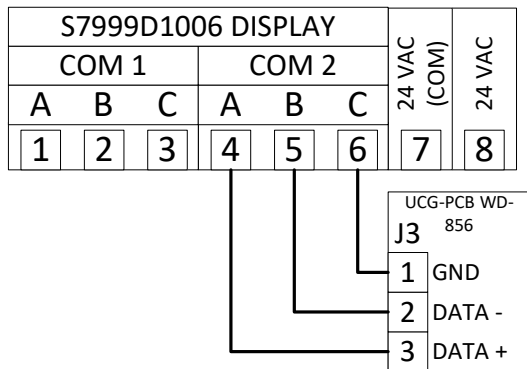

Figure 6 - Honeywell S7999 Display and UCG Connection

3.1.2 SIEMENS RWF40

Use shielded cable to connect terminals CG, CB, and CA of the Siemens RWF40 to terminals J3-1(GND), J3-2(-), and J3-3(+), of the UCG-PCB WD-856 inside the UCG. See Figure 7.

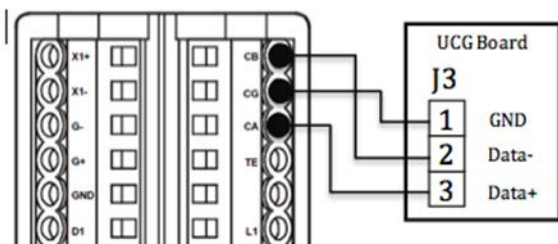

Figure 7 - Siemens RWF40 and UCG Connection

3.1.3 SIEMENS RWF55

Use shielded cable to connect terminals R-, and R+ of the Siemens RWF55 to terminals J3-2(-), and J3-3(+), of the UCG-PCB WD-856 inside the UCG. See Figure 8.

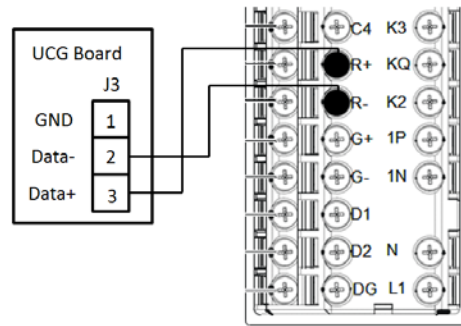

Figure 8 - Siemens RWF55 and UCG Connection

3.1.4 SIEMENS LMV2.../LMV3...

Use shielded cable to connect the burner mounted OCI412.10 RS-485 interface terminals X20.1, X20.2, and X20.3 to terminals J3-1(GND), J3-2(-), and J3-3(+), of the UCG-PCB WD-856 inside the UCG.

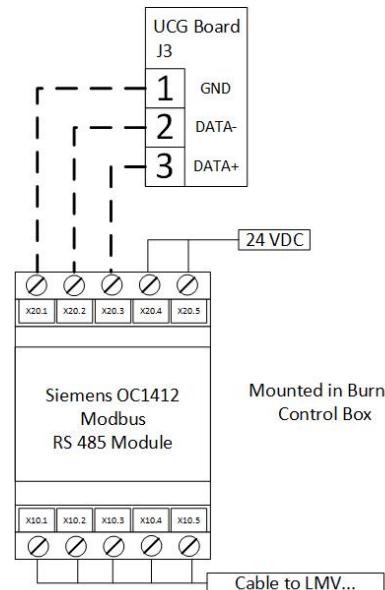

Figure 9 - Siemens LMV2.../LMV3... and UCG Connection

3.1.5 SIEMENS LMV5...

Use CAT5 twisted pair cable to connect from the RJ45 jack, COM2, of the Siemens AZL to the RJ45 jack of the UCG Serial Comm inside the UCG. See Figure 10.

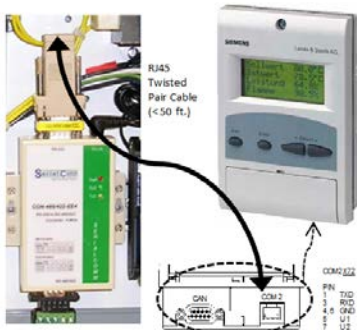

Figure 10 - LMV 5... And UCG Connection

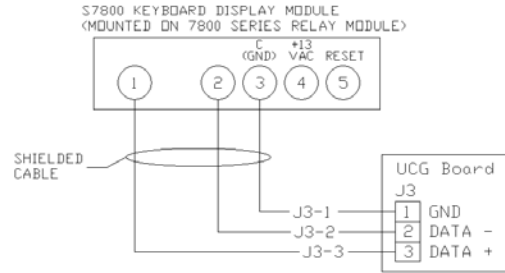

Figure 11 - Honeywell RM7800 with S7800 Keyboard Display

3.1.6.2 S7810M MODBUS™ MODULE

Use shielded cable to connect terminals 6(GND), 7(+), and 8(-) of the Honeywell S7810M ModBus Module to terminals J3-1(GND), J3-2(-), and J3-3(+), of the UCG-PCB WD-856 inside the UCG.

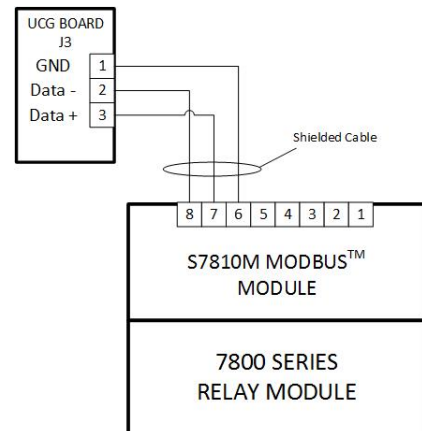

Figure 12 - RM7800 with S7810M ModBus Module

3.1.6 HONEYWELL RM7800 SERIES

The RM7800 Series flame safeguard requires a Modbus compatible Display Keyboard or Modbus Module. Please see your flame safeguard manual for details.

3.1.6.1 S7800A1142 KEYBOARD DISPLAY MODULE

Use shielded cable to connect terminals 1, 2, and 3 of the Honeywell keyboard display to terminals J3-1(GND), J3-2(-), and J3-3(+), of the UCG-PCB WD-856 inside the UCG. (The 203541 Connector may be required for connection)

3.1.7 PRECISION DIGITAL TRIDENT PD765 PANEL METER

Use shielded cable to connect terminals DO, \overline{DO} , \overline{DI} and DI of the PDA7422 Trident RS-485 Serial Adapter to terminals J3-1(GND), J3-2(-), and J3-3(+), of the UCG-PCB WD-856 inside the UCG. Connect the PDA7420 modular cable to the serial port of the meter and adapter.

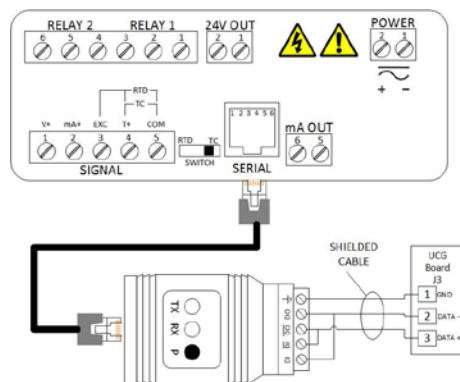

Figure 13 - Precision Digital Trident PD765 to UCG Connection

3.1.8 BOILERS EQUIPPED WITH BRYAN STEAM PRINTED CIRCUIT BOARD (WD-857)

Boilers equipped with a Bryan Steam Communication PCB (WD-857) can be interconnected using the two RJ45 jacks installed on the board. Standard CAT5 cable wired as T-568A or T-568B straight through can be used for the interconnection between the devices that are factory wired to the Bryan Steam Communication PCB (WD-857) and P1 of the UCG-PCB WD-856 inside the UCG.

The Bryan Steam Communication PCB does not need to be wired in sequential order as this will be handled in the device addressing.

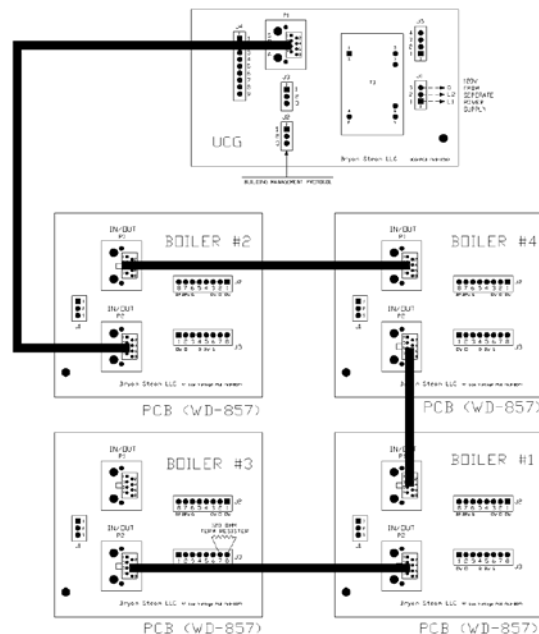

Figure 14 - Bryan Steam Communication PCB (WD-857) and Multi Boiler Connection

3.1.8.1 END OF LINE TERMINATION SWITCH

Long RS-485 cabling runs of 20ft. or more should be properly terminated at each end. If needed a 120Ω terminating resistor should be between J3-7 and J3-8 of the UCG-PCB WD-857 on each end of the trunk (See Figure 12, Boiler #3). If the UCG is placed at one of the ends of the trunk, the blue RS-485 End-of-Line Terminating switch inside the UCG will need to be moved to the ON position. Remove the cover of the ProtoNode and move the Modbus RS-485 EOL Switch to the ON position.

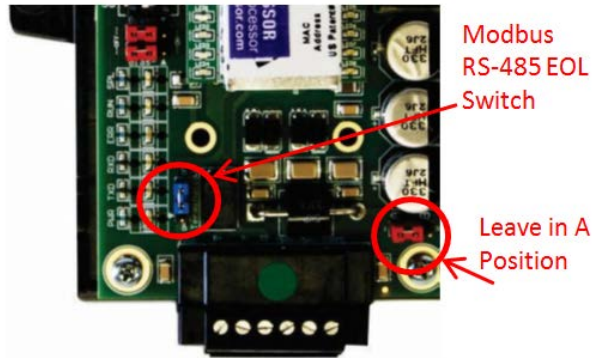

Figure 15 - End of Line Termination

Always leave the single Red Jumper in the A position.

On short cabling runs which most applications are, the EOL switch does not need to be turned ON. The default setting for this Blue EOL switch is OFF.

3.2 DEVICE MODBUS RTU COM SETTINGS

All devices connected to the UCG **MUST HAVE the same Baud Rate, Data Bits, Stop Bits, and Parity.** Refer to the UCG configuration sheet or the multi-device wiring drawing (generally shipped with boiler) for the appropriate address and baud rate settings for each device.

[Section 7.1](#) defines the installed default serial port settings for each device.

If your boiler device has a Bryan Steam ModBus Address label (Form 2445) attached to the boiler device, it has been set up and will have the address written on the label.

Set Modbus Node-ID for each of the devices attached to UCG. The Modbus Node-IDs need to be uniquely assigned between 1 and 255. Use the table in [section 8](#) to record boilers, devices and Node-ID.

- The Modbus Node-ID's assigned are used for designating the **Device Instance** for BACnet/IP and BACnet MS/TP.
- The Metasys N2 and Modbus TCP/IP field protocol Node-IDs are automatically set to be the same value as the Node-ID of the Modbus RTU device.

Select the device below:

- Honeywell SOLA see [section 3.2.1](#)
- Siemens RWF40 see [section 3.2.2](#)
- Siemens RWF55 see [section 3.2.3](#)

- Siemens LMV2.../LMV3... see [section 3.2.4](#)
- Siemens LMV5..... see [section 3.2.5](#)
- Honeywell RM7800 Series see [section 3.2.6](#)
- Trident Model PD765 Universal Input Meter [section 3.2.7](#)

3.2.1 HONEYWELL SOLA

3.2.1.1 SET SOLA ADDRESS

If you are prompted for a Passcode use **Bryan**.

Each individual SOLA will now need its own unique address. Follow these steps to setup the addressing for each SOLA:

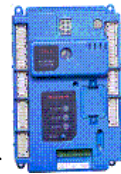

- Select the SOLA controller
- Select *Configure*
- *System Identification and Address*
- Scroll to the bottom
- Change *MB1* and *MB2* to the same Modbus address.



- Press the *Home* button
- Select *Setup*
- Select *Display Diagnostics*
- Select *Display Reset*
- **Repeat for each boiler. Numbering them accordingly.**

3.2.1.2 SOLA BMS ACTIVATION

3.2.1.2.1 TOUCH SCREEN S7999B

The S7999B display's Modbus gateway must be enabled for BAS control. From the S7999B home screen follow these steps to enable the Modbus gateway.

- Setup
- Advanced Setup
- User Preferences
- Com 2 Tab

Check the **“Enable Modbus Gateway”** box.

3.2.1.2.2 TOUCH SCREEN S7999D

Before powering on any of the boilers make sure that all communication wires are disconnected from each boiler and BMS. Apply power to all boilers. From the S7999D home screen follow these steps to enable the Modbus gateway for each SOLA:

- Setup
- Display Setup
- COM2 Tab
 - ✓ **“Enable COM2 port”**
- Check that Modbus baud rate is set at 38400 bps
- Select the Gateway tab
 - ✓ **“Enable Modbus gateway”**
- Select **“Gateway on COM2 port”**
- Select Save

Return to the home screen by pressing the home button in the upper left corner of the screen.

Reconnect all communication wires back to the boilers and BMS.

3.2.2 SIEMENS RWF40

Each RWF40 device will need to be setup with its own unique address. The decimal place, unit, and Baud rate will need to be setup the same on all devices.

Modbus settings

Press **PGM** and hold for 3 seconds, and then release to access the parameter level.



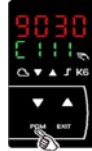

From the parameter level, advance to the configuration level by pressing **PGM** again, holding for 3 seconds, and release.





Press **PGM** and release it, to advance to C112, press **PGM** again and release it, to advance to C113.

Changing Values

Select the desired digit that needs adjusted by pressing  once and releasing it.

(Each time  is pressed and released it will cycle, thru each digit, right-to-left and back again)

To change the value of the flashing digit, press  and release it.

(Pressing  and releasing will cycle up thru the allowable values, and back again.)

Once the desired value is displayed and flashing, accept it by pressing **PGM** once and release it. If no keys are pressed for 30 seconds, at any time, the controller will automatically return to the basic display.



Unit Address

| | | |
|------------|-----|-----|
| Address 0 | 0 | 0 |
| Address 1 | 0 | 1 |
| ... | ... | ... |
| Address 99 | 9 | 9 |

Decimal place, unit, Baud rate

| | |
|---|---|
| No decimal place, degrees Celsius, 9600 Bd | 0 |
| One decimal place, degrees Celsius, 9600 Bd | 1 |
| No decimal place, degrees Fahrenheit, 9600 Bd | 2 |
| One decimal place, degrees Fahrenheit, 9600 Bd | 3 |
| No decimal place, degrees Celsius, 19200 Bd | 4 |
| One decimal place, degrees Celsius, 19200 Bd | 5 |
| No decimal place, degrees Fahrenheit, 19200 Bd | 6 |
| One decimal place, degrees Fahrenheit, 19200 Bd | 7 |
| No decimal place, degrees Celsius, 4800 Bd | 8 |
| One decimal place, degrees Celsius, 4800 Bd | 9 |
| No decimal place, degrees Fahrenheit, 4800 Bd | A |
| One decimal place, degrees Fahrenheit, 4800 Bd | b |

Signal for out-of-range

| | |
|-----------------------|---|
| Limit comparators OFF | 0 |
| Limit comparators ON | 1 |

| | | | | |
|---|---|---|---|---|
| Address 1, no decimal, °F, 9600 BAUD, compare off | 0 | 1 | 2 | 0 |
|---|---|---|---|---|

Press **EXIT** and release, to immediately return to the basic display.

The Remote Detection Timer setting is defaulted to 30 seconds. This setting will check for a signal from building management. If there is no signal, the controller will revert back to local control. To disable this set dtt equal to 0.

ConF → IntF → dtt

3.2.3 SIEMENS RWF55

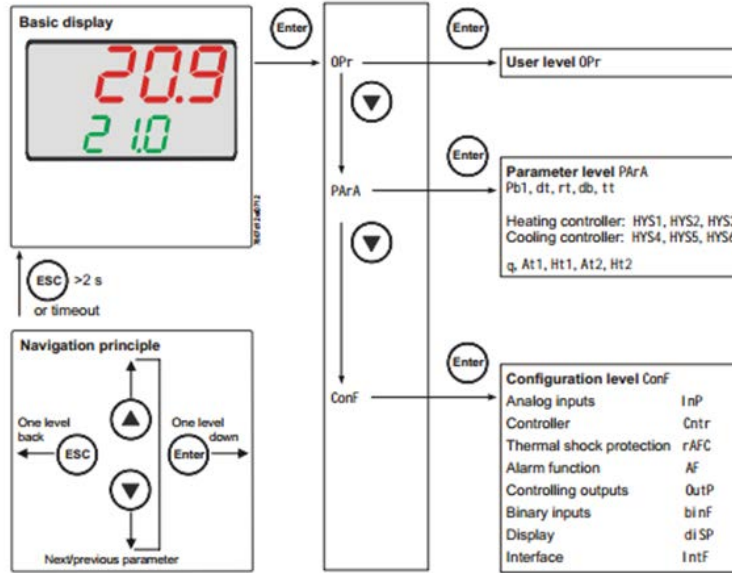

Figure 16 - Siemens RWF55 Programming

- From the basic display, press **Enter** so that **OPr** appears
- Press **▼** so that **PArA** appears
- Press **▼** so that **ConF** appears
- Press **Enter** so that the first parameter of the **ConF** level is displayed
- Press **▼** until **IntF** appears
- Press **Enter** and **r485** appears. Press **Enter** again and the first parameter **bdrt** appears.

Note: The baud rate will need to be the same on all devices connected to the UCG.

- Press **Enter** again and the **bdrt** will begin to flash.
- Use the **▼** to choose the following:
 - 1 for 9600 Baud
- Press **Enter** so that the **bdrt** stops flashing.
- Press **▼** and **Adr** is displayed.

- Press **Enter** again and the **Adr** will begin to flash.

Note: The device address will need to be different on all devices connected to the UCG. Refer to the UCG configuration sheet (generally shipped with boiler) for the appropriate address and baud rate settings for each device.







- The device address can be set from 0-254.
- Use the arrow keys to choose the device address.
- Press **Enter** and the RWF55 Setup is complete.
- The Remote Detection Timer setting is defaulted to 30 seconds. This setting will check for a signal from building management. If there is no signal, the controller will revert back to local control. To disable this set dtt equal to 0.

ConF → IntF → dtt

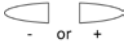
3.2.4 SIEMENS LMV2.../LMV3...



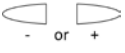

3.2.4.1 PASSCODE

The Passcode can be dependent on the burner manufacturer. The LMV2.../LMV3... passcode is "2345" or "Entry". If the passcode is incorrect, check inside the burner control box panel. You may need to contact the burner manufacturer for the correct passcode.

- Hold  simultaneously for 3 seconds, **Co d E** will momentarily be displayed
- Press  to adjust for each digit of the password
- Press  after each correct character is displayed
- Press  again after the password is complete
- **PA r A** is momentarily displayed, press  simultaneously
- **400: S E t** should be displayed, press  until **100:PArA** is displayed
- Press 

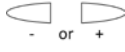
3.2.4.2 ADDRESS

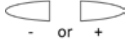
Each LMV2.../LMV3... device will need to be setup with its own unique address. Refer to the UCG configuration sheet (generally shipped with boiler) for the appropriate address and baud rate settings for each device.

- Press  until **145: 0** is displayed, press 
- Press  to change **145: 0** to **145: (*)**, press 
- Press  simultaneously

*This is the address of the individual device.

3.2.5 SIEMENS LMV5...

3.2.5.1 PASSCODE

You may need a passcode. The passcode can be dependent on the burner manufacturer. The LMV5... passcode is "9876" or "WES". If the passcode is incorrect, check inside the burner control box panel. You may need to contact the burner manufacturer for the correct passcode.

3.2.5.2 BMS ACTIVATION

Activation takes place with the AZL5 menus.

- Operation
- OptgModeSelect
- GatewayBASon

When GatewayBASon is activated, plant operation and diagnostics via the AZL... are still possible.

The internal load controller must be turned on for controlling the load with BMS. Use the display menus as shown to activate the internal load controller.

- Params&Display
- LoadController
- Configuration
- LC_OptMode
- IntLCbus

3.2.5.3 ADDRESS

The address can be selected via the AZL menu. The address can be set between 1 and 247.

- Params&Display
- AZL
- Modbus
- Address

3.2.5.4 TRANSMISSION PARAMETERS

The Baud Rate can be set via the AZL menu. This can be set to 9600 bit/s or 19200 bit/s.

- Params&Display
- AZL
- Modbus
- Baud Rate

The Parity can also be setup via the AZL menu.

- Params&Display
- AZL
- Modbus
- Parity

This can be set to "none", "even", or "odd"

3.2.5.5 TIMEOUT COMMUNICATION FAILURE

The AZL will timeout when there is no communication from the BMS. The time can be set from 0 to 7200 seconds. When this time has elapsed the BMS control mode will change from remote to local control. This can be changed via the AZL menu.

- Params&Display
- AZL
- Modbus
- Timeout

3.2.5.6 REMOTE/LOCAL

The AZL has an internal remote / local switch. This switch can only be operated from the display menus.

- ManualOperation
- Auto/Manual/Off

There are three settings for this switch.

Off – Manually turn the boiler off. All set points are ignored.

Manual – Operates in manual based on the operator’s inputted value. All set points are ignored. Normally used for commissioning the boiler.

Auto – Allows the boiler to be controlled by the BMS.

3.2.5.7 BMS OPERATING MODE

When the BAS remote / local switch is active and set to remote, control of the boiler is based on the operating mode selection.

There are three operating modes:

Off – The burner will remain off regardless of set point.

On – The burner will be controlled based on the fuel rate register #45. (Remote Firing Rate Control)

Auto – The burner will be controlled based on external set point register #44. (Remote Set point)

3.2.6 HONEYWELL RM7800 SERIES

There are two types of modules that can be used to set up communication on the RM7800.

- Keyboard Display Module S7800A see [section 3.2.6.2](#)
- Modbus Module S7810M see [section 3.2.6.1](#)

3.2.6.1 MODBUS MODULE S7810M

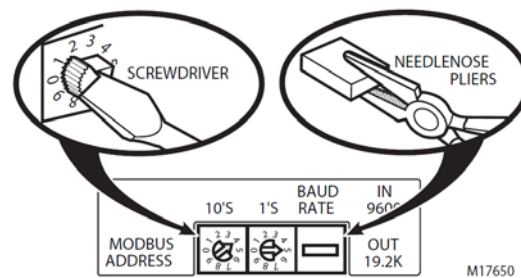

Figure 17 - 7810M Address Switches and Baud Rate Jumper

Assign a device address number from 01 to 99. “00” is not an acceptable address number and will not work.

The default baud rate is 9600. To change the baud rate to 19.2K, use needle nose pliers to remove the jumper. See Fig. 17.

3.2.6.2 KEYBOARD DISPLAY MODULE S7800A

3.2.6.2.1 BMS ACTIVATION

Press the left three buttons of the Keyboard Display Module for one second, then release.

DISPLAY Setup will appear. If you have a personal password, enter it to enter Setup.

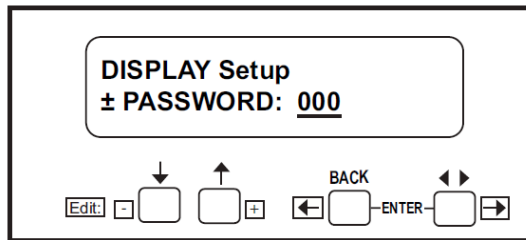

Figure 18 – Honeywell RM7800 Display Setup Screen

Press ENTER by pressing the two ENTER buttons simultaneously.



Choose Select.

Select: M B A D D R E S, then ENTER.

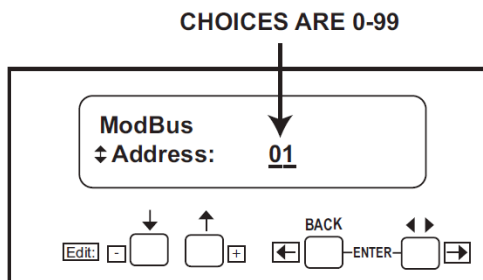

00 is the default address (Modbus off). Refer to the UCG configuration sheet (generally

shipped with boiler) for the appropriate address and baud rate settings for each device.

01-99 are available addresses.

Use ↑ and ↓ to select address. Press ENTER.

The left box blinking means ModBus activity is occurring. The right box blinking means this address is receiving activity (see Fig. 17).

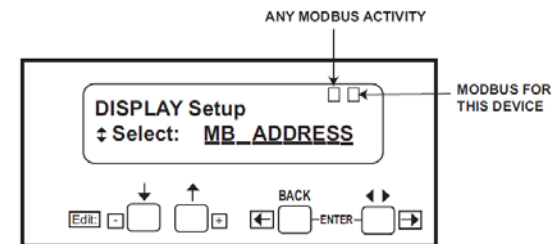
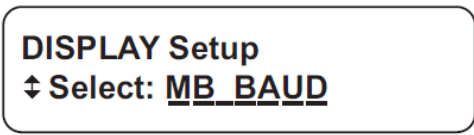

Figure 19 - Modbus Activity on RM7800

With default address 00 terminals 1, 2, 3 of the 203541 connector are available for the S7830 Expanded Annunciator or additional keyboard displays. With the addresses 01-99 enabled, ModBus is active and the S7830 Expanded Annunciator or additional displays will NOT work. If the Expanded Annunciator or additional displays are required, then order the S7810M1003 ModBus card to support the ModBus Function.

3.2.6.2.2 SETTING BAUD RATE



Display Setup MB Baud by pressing Enter.
 Scroll to MB BAUD screen.
 Select: M B B A U D.



Press ↓ to select.

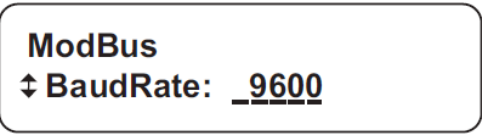

Use the ↑ and ↓ keys to change rates
 (choices are 9600, 19200, and 38400).



Press ENTER at the Save Changes/Exit No Save screen.

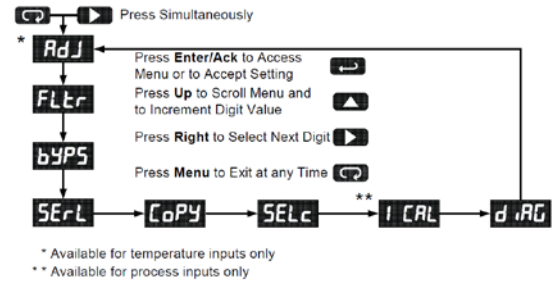

Prot - Verify that Protocol is set to Modbus.

Addr - Each meter must be provided with its own unique address from 1 to 247.

bAud - Rate must match all other devices connected to UCG.

trdE - Rate must match all other devices connected to UCG.

3.2.7 PRECISION DIGITAL TRIDENT PD765 PANEL METER

Press the Right arrow and Menu button simultaneously or hold the Menu button for approximately 3 seconds to access the Advanced Features Menu of the meter.

4 SETUP UCG

4.1 DEVICES AND POINT COUNT AVAILABILITY

- The total number of devices attached to UCG (RER) cannot exceed 1500 Modbus registers for BACnet MS/TP, BACnet/IP, Modbus TCP/IP or Metasys N2.
- The total number of devices attached to UCG (LER) cannot exceed 1000 Modbus registers for LonWorks

| Devices | Point Count |
|---------|-------------|
| SOLA | 28 |
| RWF40 | 15 |
| LMV5... | 32 |
| RM7800 | 37 |
| LMV3... | 9 |
| PD765 | 32 |

Table 2 - Modbus Registers

4.2 UCG PROTOCOL SETUP

4.2.1 CONFIGURE THE DIP SWITCHES

DIP switches on the ProtoNode, located inside UCG, may need to be set for the appropriate devices and communication settings. These DIP switches are factory preset when the field device and protocol are known at the time of ordering. If needed, remove the cover of the ProtoNode located inside the UCG.

Note: If the DIP switches need to be changed then the power to the unit will need to be shut off before proceeding.

4.2.1.1 BMS PROTOCOL (DIP SWITCH S0 – S3)

The S bank of DIP switches (S0 – S3) are used to select BACnet MS/TP, BACnet IP, Modbus TCP, or Metasys N2 configurations on the UCG (RER). The “S0 – S3” bank of DIP switches on the UCG (LER) (LonWorks) are disabled. See Table 2 below and set S bank Dip switches to the desired configuration.

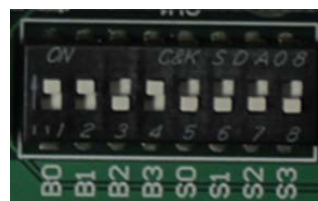

Figure 20 - S Bank DIP Switches

| UCG RER Profile | S Bank DIP Switches | | | |
|---------------------------|---------------------|-----|-----|-----|
| | S0 | S1 | S2 | S3 |
| BACnet IP | Off | Off | Off | Off |
| BACnet MSTP (multi-node) | On | Off | Off | Off |
| BACnet MSTP (single node) | Off | Off | On | Off |
| Metasys N2 | Off | On | Off | Off |
| Modbus TCP/IP | On | On | Off | Off |

Table 3 - BMS Protocol Selection

4.2.1.2 SETTING THE SERIAL BAUD RATE

DIP Switches B0 – B3 can be used to set the serial baud rate to match the baud rate provided by BMS. See Table 4 for B bank configurations.

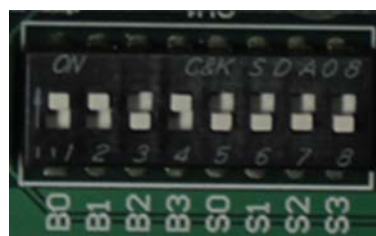

Figure 21 - B Bank DIP Switches

| Baud | B0 | B1 | B2 | B3 |
|-------|-----|-----|-----|-----|
| 9600 | On | On | On | Off |
| 19200 | Off | Off | Off | On |
| 38400 | On | On | Off | On |
| 57600 | Off | Off | On | On |
| 76800 | On | Off | On | On |

Table 4 - Baud Rate

Note: **Metasys N2 is always defaulted to 9600 baud and the B bank is disabled.**

Set up the specific protocol needed:

- **BACnet MSTP** see [section 4.2.2](#)
- **Modbus TCP/IP** see [section 4.2.3](#)
- **BACnet IP** see [section 4.2.4](#)
- **Metasys N2** see [section 4.2.5](#)
- **LonWorks** see [section 4.2.6](#)

4.2.2 BACNET MSTP SETUP

4.2.2.1 SET MAC ADDRESS

Only 1 MAC address is set for ProtoNode regardless of how many devices are connected to UCG.

Set the BACnet MSTP MAC addresses of the UCG to a value between 1 and 127 (Master MAC addresses); this is so that the BMS Front End can find the UCG via BACnet auto discovery.

Note: Never set a BACnet MSTP MAC Address of the UCG to a value from 128 to 255. Addresses from 128 to 255 are Slave Addresses and cannot be discovered by BMS Front Ends that support Auto-Discovery of BACnet MSTP devices.

Set DIP switches A0 – A7 to assign MAC Address for BACnet MSTP.

Please refer to [Section 7.2](#) for the complete range of MAC Addresses and DIP switch settings.

NOTE: When setting DIP Switches, ensure that power to the UCG is OFF.

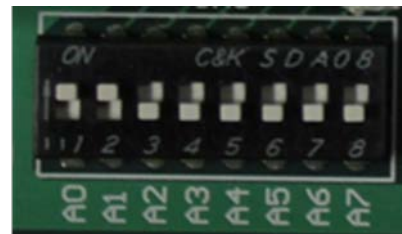

Figure 22 - A Bank DIP Switches (MAC Address)

4.2.2.2 SETTING THE DEVICE INSTANCE (NODE-ID)

The BACnet MSTP Node-ID will be set by taking the Node Offset found in the Web Configurator and adding to the value of the A Bank DIP switches (MAC Address). When more than one device is connected to the UCG, the subsequent BACnet Node-ID will be sequential. The BACnet Node-ID can range from 1 to 4,194,303.

For example:

- Node Offset (default) = 50,000
- A Bank DIP Switch (MAC Address)= 23
- Device 1 Node-ID = 50,023

To change the Node_offset see [Section 4.3.2](#). The node offset can be changed from 50,000 to 1 to 4,194,302 via the Web Configurator.

4.2.2.2.1 SET NODE_OFFSET TO ASSIGN SPECIFIC DEVICE INSTANCES FOR BACNET MS/TP

If the Device Instances need to be set for addresses other than 50,000 to 50,127, change the Node+Offset (50,000 is the default for Node+Offset). See [section 3.3.1](#) to set the PC's IP address to the same Subnet as the ProtoNode see [section 3.3.2](#) to connect to the ProtoNode's Web Configurator.

- The BACnet Device Instance can range from 1 to 4,194,303.
- BACnet MS/TP Addressing: The BACnet device instances will be set by taking the Node_Offset found in Web Configurator and adding it to the Modbus Node-ID that was assigned to the device.
- Set the PC's IP- address to be on the same subnet as the ProtoNode.
- Open the PC browser; enter the default IP address of ProtoNode 192.168.1.24, which will bring you to the FST Web Configurator landing page for the ProtoNode.
- Change the Node+Offset to meet the required device instance.

For example: Required Device Instance = 20,001

- Node_Offset changed to = 20,000.
- Device 1 has a Modbus Node-ID of 1, Device 2 has a Modbus Node-ID of 2, Device 3 has a Modbus Node-ID of 3
- Device 1 - Device Instance = 20,001
- Device 2 - Device Instance = 20,002
- Device 3 - Device Instance = 20,003

NOTE: The Modbus Node address + Node_Offset = Device Instance setting

4.2.3 MODBUS TCP/IP SETUP

When using Modbus/TCP, the A Bank of DIP switches are disabled and not used. They should be set to OFF.

4.2.3.1 SETTING THE DEVICE NODE-ID FOR MODBUS/TCP

- The Modbus RTU Node-ID's assigned to the devices attached to the UCG in [section 2](#) and will be the Modbus TCP/IP Node_ID's for the field protocols.
- Modbus/TCP Node-ID Addressing range from 1-255.

4.2.4 BACNET/IP SETUP

4.2.4.1 SETTING THE DEVICE INSTANCE

The A Bank of DIP switches are also used to set the BACnet/IP Device Instances.

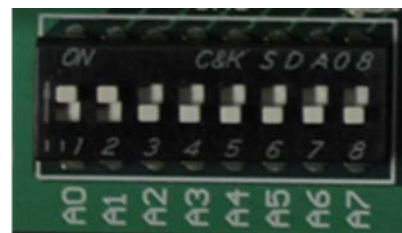

Figure 23 - A Bank DIP Switches (BACnet Address)

The BACnet/IP device instance will be set by taking the Node Offset found in section [3.3.2 Web Configurator](#) and adding to the value of the A Bank DIP switches. When more than one device is connected to the UCG, the subsequent BACnet device instances will be sequential. The BACnet Device Instance can range from 1 to 4,194,303.

For example:

- Node Offset (default) = 50,000
- A Bank DIP Switch = 23
- Device 1 Device Instance = 50,023

4.2.4.1.1 SET NODE_OFF TO ASSIGN SPECIFIC DEVICE INSTANCES FOR BACNET/IP

If the Device Instances need to be set for addresses other than 50,000 to 50,127, change the Node+Offset (50,000 is the default for Node+Offset). See [section 4.3.1](#) to set the PC's IP address to the same Subnet as the ProtoNode and [section 4.3.2](#) to connect to the ProtoNode's Web Configurator.

- The BACnet Device Instance can range from 1 to 4,194,303.
- BACnet/IP Addressing: The BACnet device instances will be set by taking the Node_Offset found in Web Configurator and adding it to the Modbus Node-ID that was assigned to the device.
- Set the PC's IP- address to be on the same subnet as the ProtoNode.
- Open the PC browser; enter the default IP address of ProtoNode

192.168.1.24, which will bring you to the FST Web Configurator landing page for the ProtoNode.

- Change the Node+Offset to meet the required device instance.

For example: Required Device Instance = 20,001

- Node_Offset changed to = 20,000.
- Device 1 has a Modbus Node-ID of 1, Device 2 has a Modbus Node-ID of 2, Device 3 has a Modbus Node-ID of 3
- Device 1 - Device Instance = 20,001
- Device 2 - Device Instance = 20,002
- Device 3 - Device Instance = 20,003

NOTE: The Modbus Node address + Node_Offset = Device Instance setting

4.2.5 METASYS N2

When using Metasys N2 the A Bank of DIP switches are disabled and not used. They should be set to OFF.

4.2.5.1 SETTING THE NODE-ID

The Modbus RTU Node-ID assigned to each device attached to the UCG in [section 2](#) will be the Metasys N2 Node-ID for the field protocols. Metasys N2 Node-ID's range from 1-255.

4.2.6 LONWORKS

Commissioning may only be performed by the LonWorks administrator.

If an XIF file is required, see steps in [section 4.2.6.2](#) to generate XIF

4.2.6.1 COMMISSIONING PROTONODE FPC-N35 ON A LONWORKS NETWORK

The User will be prompted by the LonWorks Administrator to hit the Service Pin on the ProtoNode FPC-N35 at the correct step of the Commissioning process which is different for each LonWorks Network Management Tool.



Figure 24 - LonWorks Service Pin Location

4.2.6.2 Instructions to Upload XIF File from the UCG (LER) using Field Server GUI Web Server

- Follow the steps in [section 4.3.1](#)
- Open a web browser and go to the following address: IP address of ProtoCessor/fserver.xif
- Example: 192.168.1.24/fserver.xif
- If the web browser prompts you to save file, save the file onto the PC. If the web browser displays the xif file as a web page, save the file on your PC as fserver.xif. See Figure 20.

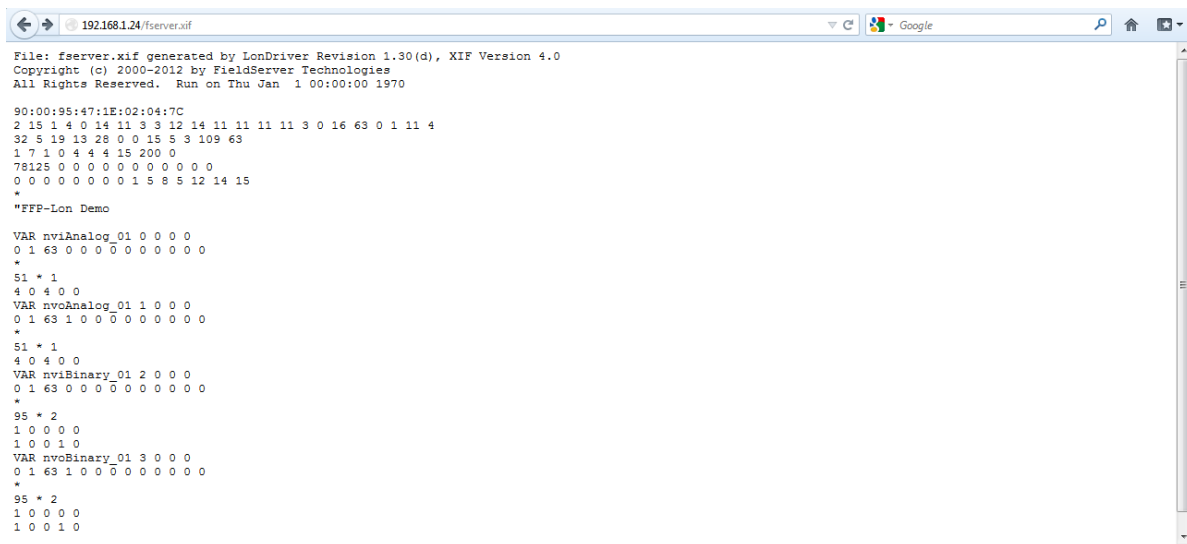

Figure 25 - Sample of Fserver.XIF File Being Generated

4.3 SETUP UCG VIA WEB CONFIGURATOR

Through the ProtoNode Web GUI Configurator parameters such as the Modbus Node-ID, Network Number, device profiles, and many other options can be set. This interface gives a quick and intuitive way to setup communication if needed.

4.3.1 CONNECT THE PC TO THE PROTONODE VIA THE ETHERNET PORT



Figure 26 - ProtoNode Ethernet Port

- Disable any wireless Ethernet adapters on the PC/Laptop.
- Disable firewall and virus protection software.
- Connect a standard CAT5 Ethernet cable (straight through **or** cross) between the PC and ProtoNode inside the UCG.
- The default IP Address of the ProtoNode is 192.168.1.24, Subnet Mask is 255.255.255.0. If the PC and the ProtoNode are on different IP Networks, assign a static IP Address to the PC on the 192.168.1.xxx network.

• For Windows XP



• For Windows 7

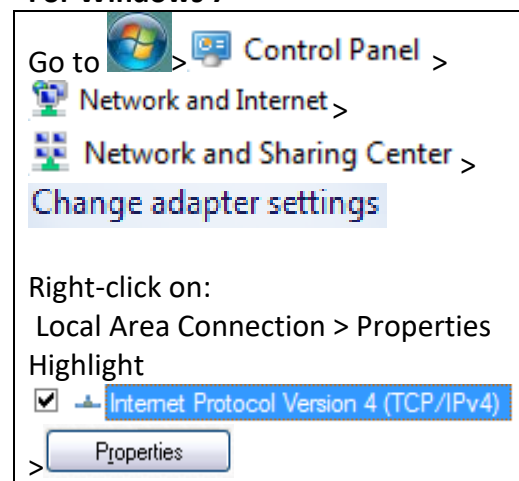

• For Windows XP and Windows 7, select:

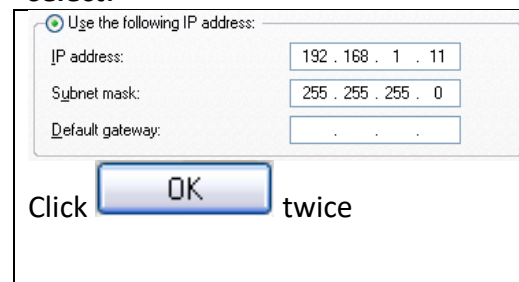

4.3.2 CONFIGURE PROFILES IN PROTONODE'S WEB CONFIGURATOR

- Follow the steps in [section 4.3.1](#) .
- Open PC web browser and enter the default IP address of the ProtoNode 192.168.1.24
- When the S bank of DIP switches are set for BACnet MS/TP or BACnet/IP or Metasys N2 or Modbus TCP/IP, profiles for all of the devices for that particular protocol will be listed in the Configurator.

4.3.2.1 SELECTING THE DEVICE'S PROFILES THAT WILL BE CONNECTED PROTONODE

When you open the Web Configurator, you will see the available device Profiles on the lower left side of the screen. Use the drop-down box under "Current Profile" to view all of the available profiles.

To active a profile for a device, select the device from the drop-down list, then click the "Add" button. For every device that will be connected, you will need to add an Active Profile and declare the Modbus Node Address that was assigned to the device.

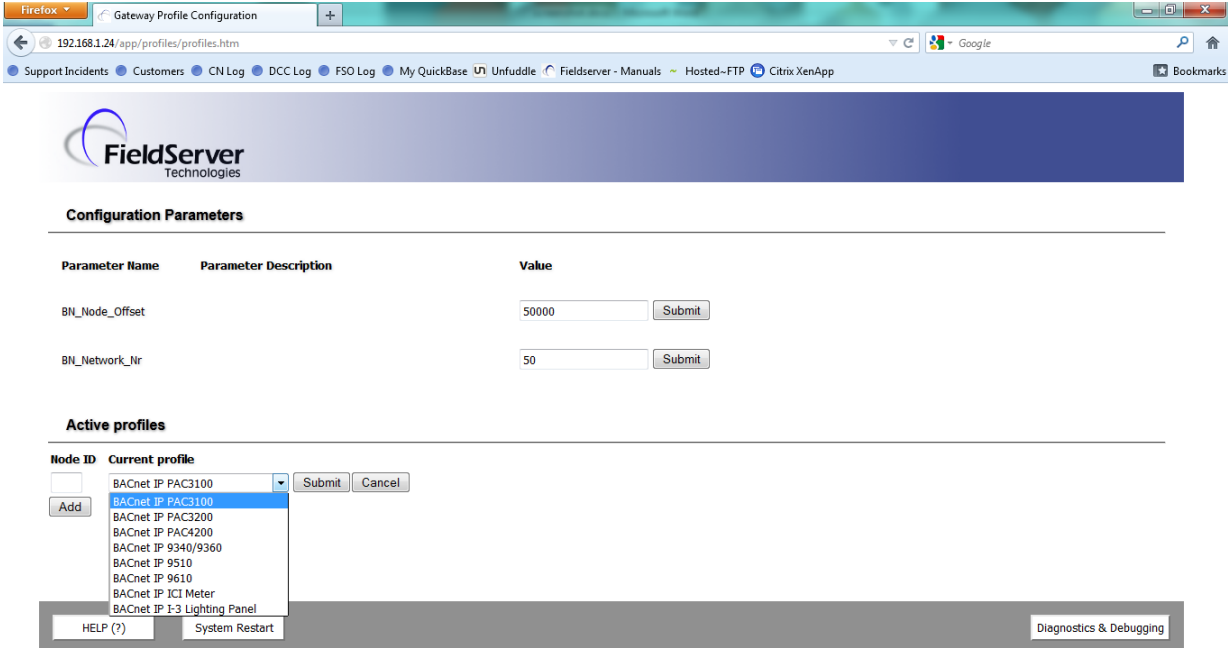

Figure 27 - Web Configurator Showing the Active Profiles to Select From

Once the Profile has been selected and the Modbus Node Address has been declared, click the “Add” button to activate the Profile for inclusion in the configuration.

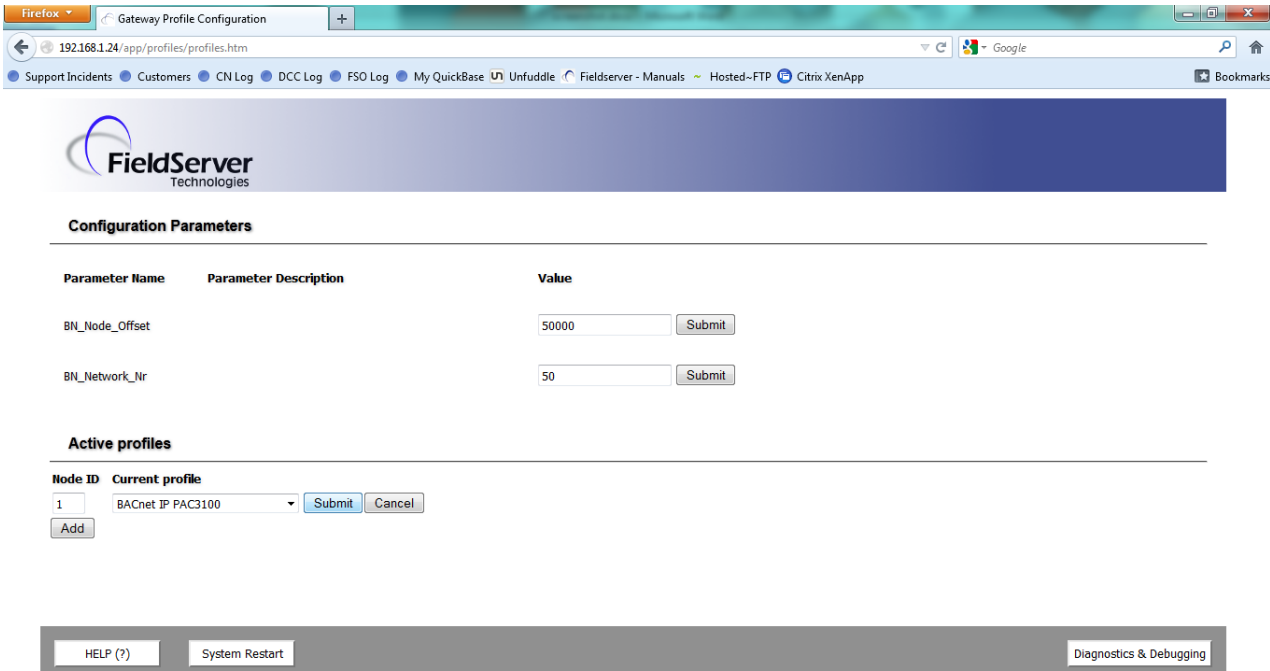

Figure 28 - Web Configurator Showing a Profile Selected

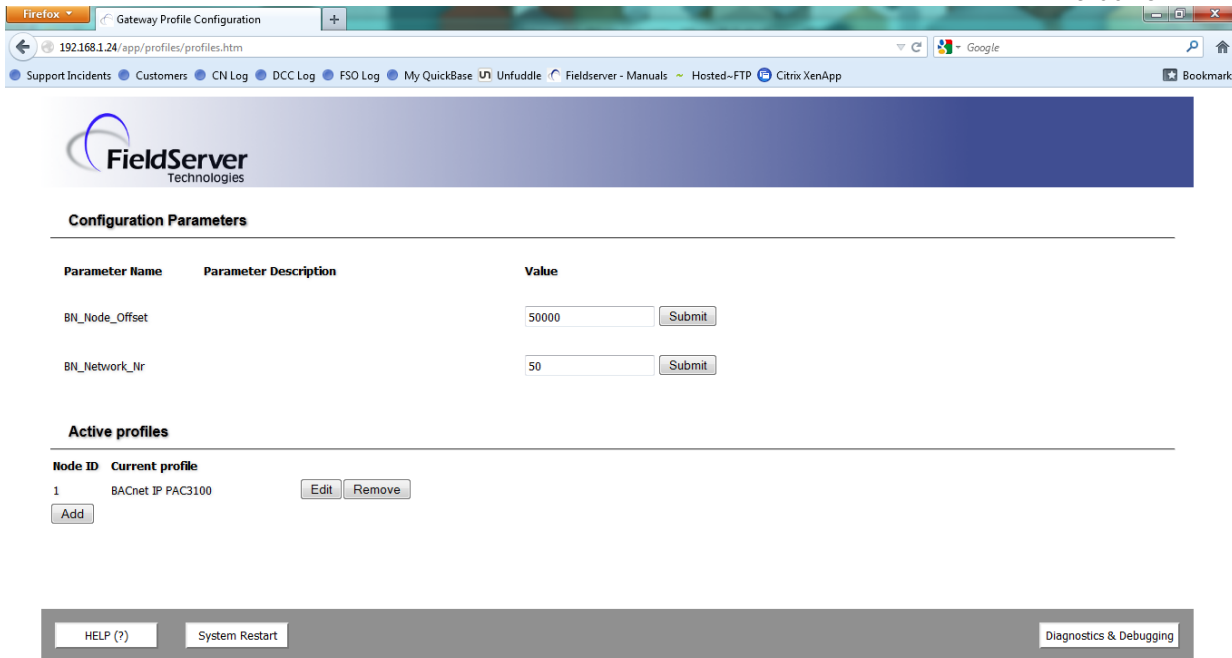

Figure 29 - Web Configurator Showing a Completed Profile Added

Continue this process until all devices have been added.

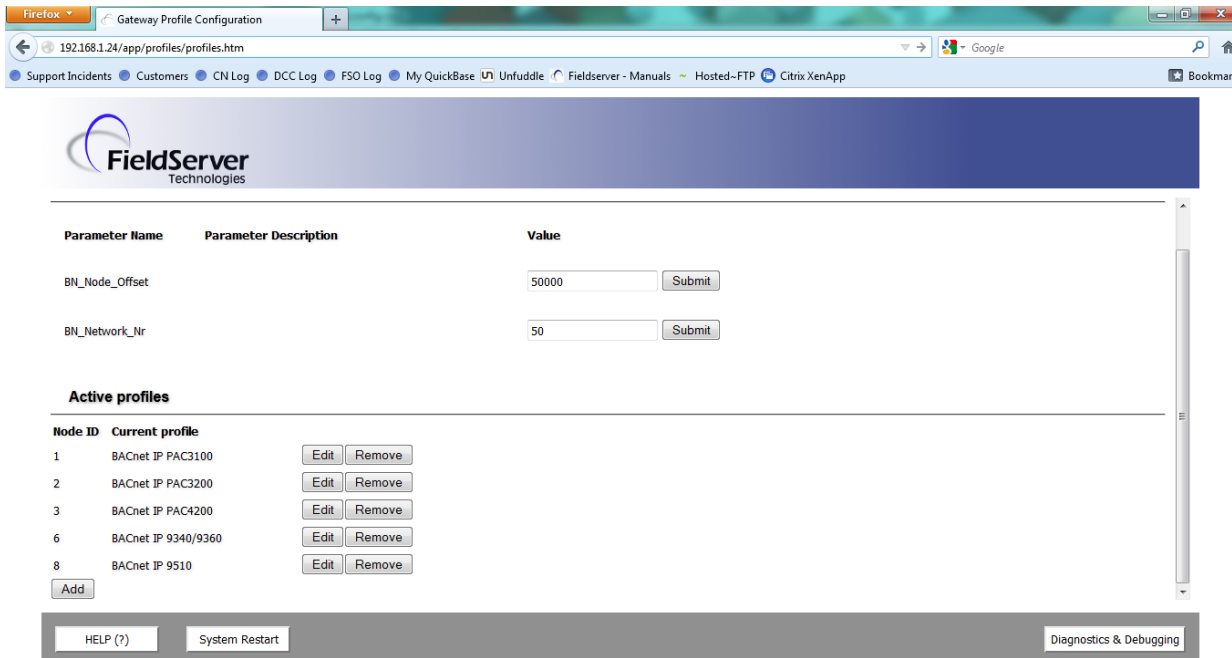

Figure 30 - Web Configurator Showing Completed Profiles Added

4.3.3 SET IP ADDRESS FOR BACNET/IP VIA GUI

- Open a PC web browser, enter the default IP address of ProtoNode 192.168.1.24 and connect to ProtoNode.
- The Default GUI landing page is the Web Configurator.
- Press the Diagnostics and Debugging button at the bottom right corner of the page to go to FSGUI utility.

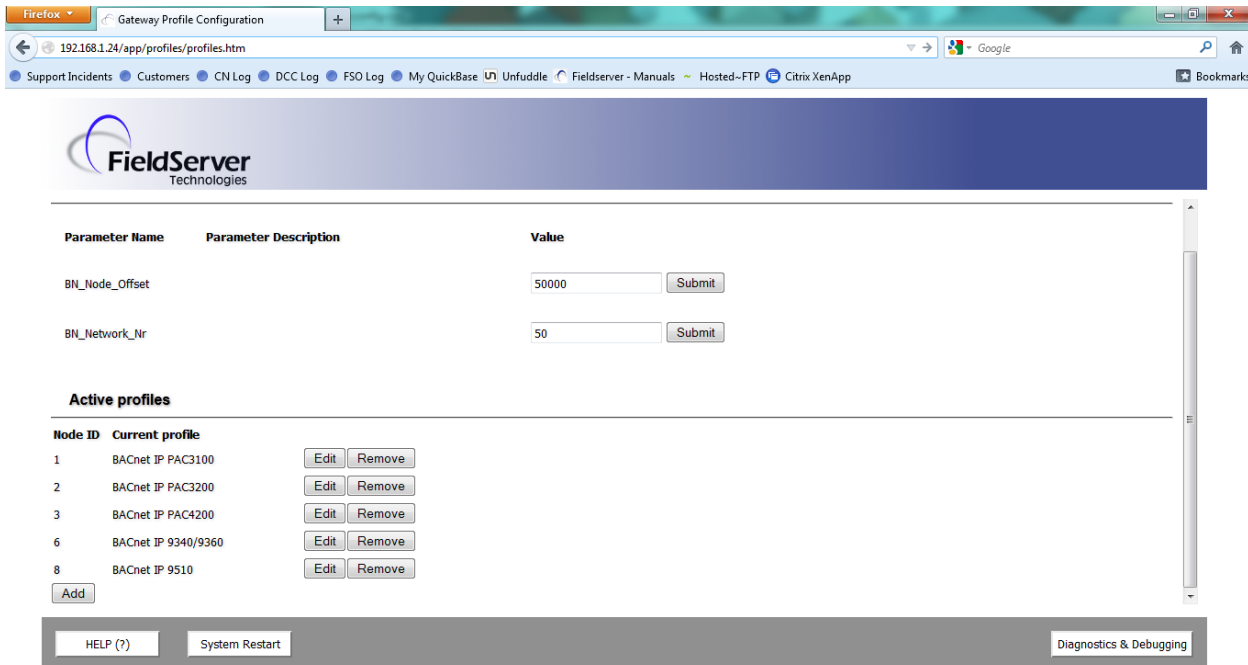

Figure 31 - Default FS Web GUI Landing Page

- Click on setup and then Network Settings to enter the Edit IP Address Settings menu.

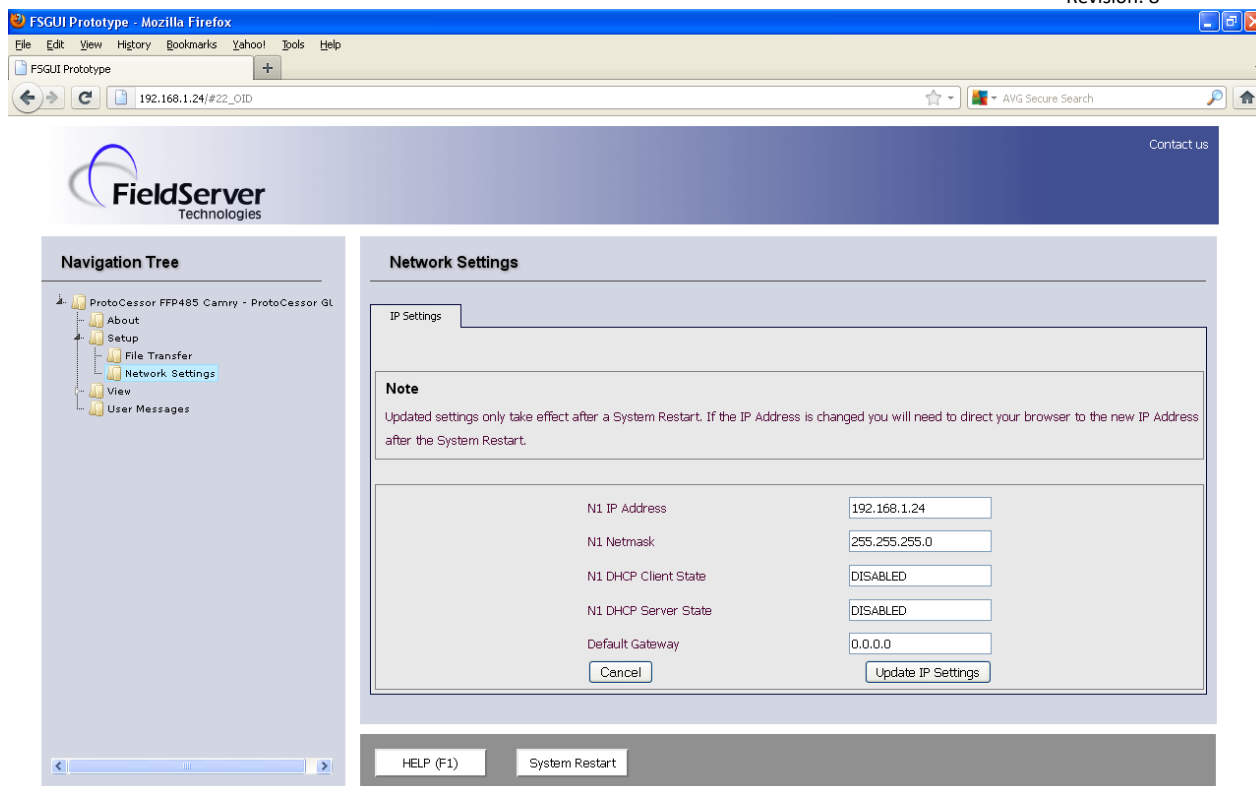

Figure 32 - Changing IP Address via FST Web GUI

- Modify the IP address (N1 IP address field) of ProtoNode Ethernet port.
- If necessary, change the Netmask (N1 Netmask field).
- Type in a new Subnet Mask.
- If necessary, change the IP Gateway (Default Gateway field).
- Type in a new IP Gateway.
- Note: If ProtoNode is connected to a router, the IP Gateway of ProtoNode should be set to the IP address of the router that it is connected to.
- Reset ProtoNode.
- **Unplug Ethernet cable from PC and connect it to the network hub or router.**

5 POINTS LISTS

5.1 HONEYWELL SOLA MODBUS RTU MAPPINGS TO BACNET, METASYS N2 AND LONWORKS

See Honeywell SOLA device manual for more information.

| Point Name | Description | FPC-N34 | | | | FPC-N35 | |
|--------------------------|--|------------------|------------------|--------------|------------------|------------------|---------------|
| | | BACnet Data Type | BACnet Object Id | N2 Data Type | N2 Point Address | Lon Name | Lon SNVT Type |
| Com Status | 1 = Communication Established 0 = No Communication | BI | 1 | DI | 1 | nvoComStatus_XXX | SNVT_switch |
| Demand source | Current demand source: 0=Unknown, 1=No source demand, 2=CH, 3=DHW, 4=Lead Lag slave, 5=Lead Lag master, 6=CH frost protection, 7=DHW frost protection, 8=No demand due to burner switch turned off, 9=DHW storage, 10=Reserved, 11=Warm weather shutdown | AI | 1 | AI | 1 | nvoDemSrc_XXX | SNVT_count_f |
| Outlet sensor | Boiler supply water temperature. | AI | 2 | AI | 2 | nvoOutletSen_XXX | SNVT_temp_f |
| Fan speed | Speed of the combustion air blower in rpm. | AI | 3 | AI | 3 | nvoFanSpeed_XXX | SNVT_count_f |
| Flame signal | Signal strength of the flame 0 – 15 VDC. | AI | 4 | AI | 4 | nvoFlmSignal_XXX | SNVT_count_f |
| Inlet sensor | Boilers return water temperature. | AI | 5 | AI | 5 | nvoInletSen_XXX | SNVT_temp_f |
| DHW sensor | Domestic hot water temperature. | AI | 6 | AI | 6 | nvoDHW_Sen_XXX | SNVT_temp_f |
| S5 sensor | Header water temperature or outdoor temperature. | AI | 7 | AI | 7 | nvoS5Sensor_XXX | SNVT_temp_f |
| Stack sensor | Temperature of the flue gasses. | AI | 8 | AI | 8 | nvoStackSen_XXX | SNVT_temp_f |
| 4-20 mA remote ctl input | The mA value for S2 (J8-6) (remote set point) & (remote modulation). | AI | 9 | AI | 9 | nvoRemCtlIn_XXX | SNVT_count_f |
| Burner control status | 0=Disabled, 1=Locked out, 4=Anti-short cycle, 5=Unconfigured safety data, 34=Standby Hold, 35=Standby Delay, 48=Normal Standby, 49=Preparing, 50=Ignition, 51=Firing, 52=Postpurge | AI | 10 | AI | 10 | nvoBrnCtIst_XXX | SNVT_count_f |
| Lockout code | 0 = No lockout 1 – 4096 (see table 9 of the SOLA Modbus Interface Manual) | AI | 11 | AI | 11 | nvoLockotCod_XXX | SNVT_count_f |
| Annunciator first out | 0 = None or undetermined 1 = Running interlock (Air flow switch) 2 = Pre ignition interlock (Proof of valve closure when provided) 11 = Boiler low water 12 = High internal burner temperature 13 = Water flow switch 14 = High gas pressure 15 = Low gas pressure | AI | 12 | AI | 12 | nvoAnn1stOut_XXX | SNVT_count_f |

| | | | | | | | |
|-------------------------|--|----|----|----|----|--------------------------|--------------|
| | 16 = Low pilot gas pressure 17 = High air exchanger pressure 18 = High burner air pressure | | | | | | |
| Burner cycle count | 0-999,999 (U32) | AI | 13 | AI | 13 | nvoBrnCycCnt_XXX | SNVT_count_f |
| Burner run time | Hours (U32) | AI | 14 | AI | 14 | nvoBrnRunTim_XXX | SNVT_count_f |
| CH pump cycle count | 0-999,999 (U32) | AI | 15 | AI | 15 | nvoCHPmpCyCn_XX X | SNVT_count_f |
| DHW pump cycle count | 0-999,999 (U32) | AI | 16 | AI | 16 | nvoDHWpMcyCt_X XX | SNVT_count_f |
| System pump cycle count | 0-999,999 (U32) | AI | 17 | AI | 17 | nvoSysPmCyCt_XXX | SNVT_count_f |
| Boiler pump cycle count | 0-999,999 (U32) | AI | 18 | AI | 18 | nvoBlrPmCyCt_XXX | SNVT_count_f |
| Outdoor temperature | Temperature of the remote outdoor sensor | AI | 19 | AI | 19 | nvoOutdrTmp_XXX | SNVT_temp_f |
| Burner switch | Used to Enable/Disable boiler firing 1 = Enabled 0 = Disabled | BV | 20 | DO | 20 | nvi/nvoBurnerSw_X XX | SNVT_switch |
| CH enable | Enable/Disable central heating 1 = Enabled 0 = Disabled | BV | 21 | DO | 21 | nvi/nvoCH_Enable_ XXX | SNVT_switch |
| CH setpoint | Change Boiler Set point ¹ | AV | 22 | AO | 22 | nvi/nvoCH_SP_XXX | SNVT_temp_f |
| CH TOD setpoint | Boiler Set point when Time of Day switch is on ¹ | AV | 23 | AO | 23 | nvi/nvoCH_TOD_SP_ XXX | SNVT_temp_f |
| DHW Enable | Enable/Disable domestic hot water. 1 = Enabled 0 = Disabled | BV | 24 | DO | 24 | nvi/nvoDHW_Enabl_ XXX | SNVT_switch |
| DHW Setpoint | Change the domestic hot water set point ¹ | AV | 25 | AO | 25 | nvi/nvoDHW_SP_X XX | SNVT_temp_f |
| Lead Lag setpoint | Change the lead lag set point ¹ | AV | 26 | AO | 26 | nvi/nvoLeadLagSP_ XXX | SNVT_temp_f |
| Lead Lag enable | Enable/ Disable Lead Lag 1 = Enabled 0 = Disabled | BV | 27 | DO | 27 | nvi/nvoLdLgEnabl_X XX | SNVT_switch |

¹ All temperature registers are expressed in °C regardless what Temperature units (register 179) is set to. Temperature range is -40°C to 130°C with values given in 0.1°C units (for example, 32.0°C = 320). A temperature that is NOT applicable in this SOLA, i.e., not enabled, has a value of 0x8FFF. This temperature setting is denoted as "UNCONFIGURED" at the user interface.

5.2 SEIMENS RWF55 MODBUS RTU MAPPINGS TO BACNET, METASYS N2 AND LONWORKS

See Siemens RWF55 device manual for more information.

| Point Name | FPC-N34 | | | | FPC-N35 | |
|-------------------------------------|------------------|------------------|--------------|------------------|------------------|------------------|
| | BACnet Data Type | BACnet Object Id | N2 Data Type | N2 Point Address | Lon Name | Lon SNVT Type |
| Com Status | BI | 1 | DI | 1 | nvoComStatus_XXX | SNVT_switch |
| Analog Input InP1 | AI | 1 | AI | 1 | nvolnP1_XXX | SNVT_count_inc_f |
| Analog Input InP2 | AI | 2 | AI | 2 | nvolnP2_XXX | SNVT_count_inc_f |
| Analog Input InP3 | AI | 3 | AI | 3 | nvolnP3_XXX | SNVT_count_inc_f |
| Actual Setpoint | AI | 4 | AI | 4 | nvoActSP_XXX | SNVT_count_inc_f |
| Setpoint 1 | AV | 5 | AO | 5 | nvi/nvoSP_1_XXX | SNVT_count_inc_f |
| Setpoint 2 | AV | 6 | AO | 6 | nvi/nvoSP_2_XXX | SNVT_count_inc_f |
| Analog Input InP3 | AI | 7 | AI | 7 | nvolnP3Unfil_XXX | SNVT_count_inc_f |
| Actual Angular Positioning | AI | 8 | AI | 8 | nvoActAngPos_XXX | SNVT_count_inc_f |
| Burner Alarm | AI | 9 | AI | 9 | nvoBrnrAlm_XXX | SNVT_count_inc_f |
| Activation Remote Operation | AV | 10 | AO | 10 | nvi/nvoREM_XXX | SNVT_count_inc_f |
| Controller Off In Remote Setpoint | AV | 11 | AO | 11 | nvi/nvorOFF_XXX | SNVT_count_inc_f |
| Switch-On Threshold Remote | AV | 12 | AO | 12 | nvi/nvorHYS1_XXX | SNVT_count_inc_f |
| Switch-Off Threshold Down Remote | AV | 13 | AO | 13 | nvi/nvorHYS2_XXX | SNVT_count_inc_f |
| Switch-Off Threshold Up Remote | AV | 14 | AO | 14 | nvi/nvorHYS3_XXX | SNVT_count_inc_f |
| Setpoint Remote | AV | 15 | AO | 15 | nvi/nvoSPr_XXX | SNVT_count_inc_f |
| Burner Release Remote Operation | AV | 16 | AO | 16 | nvi/nvoRK1_XXX | SNVT_count_inc_f |
| Relay K2 Remote Operation | AV | 17 | AO | 17 | nvi/nvoRK2_XXX | SNVT_count_inc_f |
| Relay K3 Remote Operation | AV | 18 | AO | 18 | nvi/nvoRK3_XXX | SNVT_count_inc_f |
| Relay K6 Remote Operation | AV | 19 | AO | 19 | nvi/nvoRK6_XXX | SNVT_count_inc_f |
| Step-By-Step Control Rem Operation | AV | 20 | AO | 20 | nvi/nvorStEP_XXX | SNVT_count_inc_f |
| Angular Pos Output Remote Operation | AV | 21 | AO | 21 | nvi/nvorY_XXX | SNVT_count_inc_f |
| Switch-On Threshold Remote | AV | 22 | AO | 22 | nvi/nvorHYS4_XXX | SNVT_count_inc_f |
| Switch-Off Threshold Down Remote | AV | 23 | AO | 23 | nvi/nvorHYS5_XXX | SNVT_count_inc_f |
| Switch-Off Threshold Up Remote | AV | 24 | AO | 24 | nvi/nvorHYS6_XXX | SNVT_count_inc_f |

5.3 SIEMENS LMV52 MODBUS RTU MAPPINGS TO BACNET, METASYS N2 AND LONWORKS

See Siemens LMV52 device manual for more information.

| LMV52 Modbus RTU Mappings to BACnet, Metasys N2 and LonWorks | | | | | | | |
|--|---------------------------------------|--------------------|------------------|--------------|------------|---------------------|------------------|
| Ref. | Point Name | BACnet Object Type | BACnet Object ID | N2 Data Type | N2 Address | LonWorks Name | LonWorks SNVT |
| 1 | Com Status | BI | 1 | DI | 1 | nvoComStatus_XXX | SNVT_switch |
| 2 | Process Value | AI | 1 | AI | 1 | nvoProcVal_XXX | SNVT_count_f |
| 3 | Flame Signal | AI | 2 | AI | 2 | nvoFlameSig_XXX | SNVT_lev_percent |
| 4 | Fuel Rate Volume | AI | 3 | AI | 3 | nvoFuelRtVol_XXX | SNVT_count_f |
| 5 | O2 Level | AI | 4 | AI | 4 | nvoO2Level_XXX | SNVT_lev_percent |
| 6 | Supply Air | AI | 5 | AI | 5 | nvoSupplyAir_XXX | SNVT_count_f |
| 7 | Flue Gas | AI | 6 | AI | 6 | nvoFlueGas_XXX | SNVT_count_f |
| 8 | Combustion Efficiency | AI | 7 | AI | 7 | nvoCombstEff_XXX | SNVT_lev_percent |
| 9 | Control Mode | BV | 8 | DO | 8 | nvi/nvoCtrlMode_XXX | SNVT_switch |
| 10 | Operating Mode | AV | 9 | AO | 9 | nvi/nvoOpMode_XXX | SNVT_count_f |
| 11 | External Setpoint | AV | 10 | AO | 10 | nvi/nvoExtSP_XXX | SNVT_count_f |
| 12 | Fuel Rate | AV | 11 | AO | 11 | nvi/nvoFuelRate_XXX | SNVT_count_f |
| 13 | Process Setpoint | AV | 12 | AO | 12 | nvi/nvoProcSP_XXX | SNVT_count_f |
| 14 | Hours | AI | 13 | AI | 13 | nvoHours_XXX | SNVT_time_hour |
| 15 | Current Lockout Error code | AI | 14 | AI | 14 | nvoCrntErCd_XXX | SNVT_count_f |
| 16 | Current Lockout Error diagnosis | AI | 15 | AI | 15 | nvoCrntErDg_XXX | SNVT_count_f |
| 17 | Current Lockout Error class | AI | 16 | AI | 16 | nvoCrntErCls_XXX | SNVT_count_f |
| 18 | Current Lockout Error phase | AI | 17 | AI | 17 | nvoCrntErPh_XXX | SNVT_count_f |
| 19 | Current Lockout Fuel | AI | 18 | AI | 18 | nvoCrntFuel_XXX | SNVT_count_f |
| 20 | Current Lockout Output | AI | 19 | AI | 19 | nvoCrntOutpt_XXX | SNVT_count_f |
| 21 | Current Lockout Date: Year | AI | 20 | AI | 20 | nvoCrntTPDYr_XXX | SNVT_count_f |
| 22 | Current Lockout Date: Month | AI | 21 | AI | 21 | nvoCrntTPDMn_XXX | SNVT_count_f |
| 23 | Current Lockout Date: Day | AI | 22 | AI | 22 | nvoCrntTPDDy_XXX | SNVT_count_f |
| 24 | Current Lockout Time of day: hours | AI | 23 | AI | 23 | nvoCrntTODHr_XXX | SNVT_count_f |
| 25 | Current Lockout Time of day: minutes | AI | 24 | AI | 24 | nvoCrntTODMn_XXX | SNVT_count_f |
| 26 | Current Lockout Time of day: Seconds | AI | 25 | AI | 25 | nvoCrntTODSc_XXX | SNVT_count_f |
| 27 | Current Lockout Startup counter total | AI | 26 | AI | 26 | nvoCrntStCtT_XXX | SNVT_count_f |
| 28 | Current Lockout Hours run total | AI | 27 | AI | 27 | nvoCrntHrRnT_XXX | SNVT_time_hour |
| 29 | Lockout Error Code | AI | 140 | AI | 140 | nvoLckotErCd_XXX | SNVT_count_f |
| 30 | Lockout Diagnostic Code | AI | 141 | AI | 141 | nvoLckotDgCd_XXX | SNVT_count_f |
| 31 | Fuel Selected | AI | 142 | AI | 142 | nvoFuelSel_XXX | SNVT_count_f |
| 32 | Firing Rate | AI | 143 | AI | 143 | nvoFirRate_XXX | SNVT_count_f |

5.4 HONEYWELL RM7800 MODBUS RTU MAPPINGS TO BACNET, METASYS N2 AND LONWORKS

See Honeywell RM7800 device manual for operation.

| RM7800 Modbus RTU Mappings to BACnet, Metasys N2 and LonWorks | | | | | | | |
|---|-------------------------------|--------------------|------------------|--------------|------------|------------------|----------------|
| Ref. | Point Name | BACnet Object Type | BACnet Object ID | N2 Data Type | N2 Address | LonWorks Name | LonWorks SNVT |
| 1 | Com Status | BI | 1 | DI | 1 | nvoComStatus_XXX | SNVT_switch |
| 2 | Flame Signal | AI | 1 | AI | 1 | nvoFlameSig_XXX | SNVT_count_f |
| 3 | Burner Cycles | AI | 2 | AI | 2 | nvoBrnCyc_XXX | SNVT_count_f |
| 4 | Burner Hours | AI | 3 | AI | 3 | nvoBrnHrs_XXX | SNVT_time_hour |
| 5 | Burner Fault Code | AI | 4 | AI | 4 | nvoBrnFltCod_XXX | SNVT_count_f |
| 6 | Initiate | AI | 53 | AI | 53 | nvoInitiate_XXX | SNVT_switch |
| 7 | Standby | AI | 54 | AI | 54 | nvoStandby_XXX | SNVT_switch |
| 8 | Purge | AI | 55 | AI | 55 | nvoPurge_XXX | SNVT_switch |
| 9 | Pilot Ignition | AI | 56 | AI | 56 | nvoPilotIgn_XXX | SNVT_switch |
| 10 | Main Ignition | AI | 57 | AI | 57 | nvoMainIgn_XXX | SNVT_switch |
| 11 | Run | AI | 58 | AI | 58 | nvoRun_XXX | SNVT_switch |
| 12 | Postpurge | AI | 59 | AI | 59 | nvoPostpurge_XXX | SNVT_switch |
| 13 | Pre-Ignition | AI | 60 | AI | 60 | nvoPreIgntn_XXX | SNVT_switch |
| 14 | Valve Proving | AI | 61 | AI | 61 | nvoVlvProv_XXX | SNVT_switch |
| 15 | Alarm | AI | 62 | AI | 62 | nvoAlarm_XXX | SNVT_switch |
| 16 | Hold | AI | 63 | AI | 63 | nvoHold_XXX | SNVT_switch |
| 17 | Lockout | AI | 64 | AI | 64 | nvoLockout_XXX | SNVT_switch |
| 18 | First Out Code * | AI | 65 | AI | 65 | nvo1stOutCod_XXX | SNVT_count_f |
| 19 | Main Valve Proof of Closure * | BI | 66 | DI | 66 | nvoMnVlvCls_XXX | SNVT_switch |
| 20 | Burner Switch * | BI | 67 | DI | 67 | nvoBrnrSw_XXX | SNVT_switch |
| 21 | Operating Control * | BI | 68 | DI | 68 | nvoOpCtrl_XXX | SNVT_switch |
| 22 | Auxiliary Limit 1 * | BI | 69 | DI | 69 | nvoAuxLim1_XXX | SNVT_switch |
| 23 | Auxiliary Limit 2 * | BI | 70 | DI | 70 | nvoAuxLim2_XXX | SNVT_switch |
| 24 | Low Water Cutoff * | BI | 71 | DI | 71 | nvoLoWtrCut_XXX | SNVT_switch |
| 25 | High Limit * | BI | 72 | DI | 72 | nvoHiLim_XXX | SNVT_switch |
| 26 | Auxiliary Limit 3 * | BI | 73 | DI | 73 | nvoAuxLim3_XXX | SNVT_switch |
| 27 | Oil Select Switch * | BI | 74 | DI | 74 | nvoOilSelSw_XXX | SNVT_switch |
| 28 | High Oil Pressure * | BI | 75 | DI | 75 | nvoHiOilPrs_XXX | SNVT_switch |
| 29 | Low Oil Pressure * | BI | 76 | DI | 76 | nvoLoOilPrs_XXX | SNVT_switch |
| 30 | High Oil Temperature * | BI | 77 | DI | 77 | nvoHiOilTmp_XXX | SNVT_switch |
| 31 | Low Oil Temperature * | BI | 78 | DI | 78 | nvoLoOilTmp_XXX | SNVT_switch |
| 32 | Gas Select Switch * | BI | 79 | DI | 79 | nvoGasSelSw_XXX | SNVT_switch |
| 33 | High Gas Pressure * | BI | 80 | DI | 80 | nvoHiGasPrs_XXX | SNVT_switch |
| 34 | Low Gas Pressure * | BI | 81 | DI | 81 | nvoLoGasPrs_XXX | SNVT_switch |
| 35 | Air Flow Switch * | BI | 82 | DI | 82 | nvoAirFLoSw_XXX | SNVT_switch |
| 36 | Auxiliary Interlock 4 * | BI | 83 | DI | 83 | nvoAuxIntlk4_XXX | SNVT_switch |
| 37 | Auxiliary Interlock 5 * | BI | 84 | DI | 84 | nvoAuxIntlk5_XXX | SNVT_switch |

*Requires S7830 Expanded Annunciator

5.5 SEIMENS LMV 36 MODBUS RTU MAPPINGS TO BACNET, METASYS N2 AND LONWORKS

See Seimens LMV 36 device manual for operation.

| LM36 Modbus RTU Mappings to BACnet, Metasys N2 and LonWorks | | | | | | | |
|---|-------------------------|--------------------|------------------|--------------|------------|---------------------|------------------|
| Ref. | Point Name | BACnet Object Type | BACnet Object ID | N2 Data Type | N2 Address | LonWorks Name | LonWorks SNVT |
| 1 | Com Status | BI | 1 | DI | 1 | nvoComStatus_XXX | SNVT_switch |
| 2 | Flame Signal | AI | 1 | AI | 1 | nvoFlameSig_XXX | SNVT_lev_percent |
| 3 | Lockout Error Code | AI | 2 | AI | 2 | nvoLckotErCd_XXX | SNVT_count_f |
| 4 | Lockout Diagnostic Code | AI | 3 | AI | 3 | nvoLckotDgCd_XXX | SNVT_count_f |
| 5 | Control Mode | BV | 4 | DO | 4 | nvi/nvoCtrlMode_XXX | SNVT_switch |
| 6 | Operating Mode | AV | 5 | AO | 5 | nvi/nvoOp_Mode_XXX | SNVT_count_f |
| 7 | Fuel Rate | AV | 6 | AO | 6 | nvi/nvoFuelRate_XXX | SNVT_count_f |
| 8 | Fuel Selected | AI | 7 | AI | 7 | nvoFuelSel_XXX | SNVT_count_f |
| 9 | Firing Rate | AI | 8 | AI | 8 | nvoFirRate_XXX | SNVT_count_f |

5.6 PRECISION DIGITAL TRIDENT PD765 MODBUS RTU MAPPINGS TO BACNET, METASYS N2 AND LONWORKS

See Precision Digital Trident PD765 device manual for operation.

| PD765 Modbus RTU Mappings to BACnet, Metasys N2 and LonWorks | | | | | | | |
|--|--------------------------------------|--------------------|------------------|--------------|------------|-----------------------|---------------|
| Ref. | Point Name | BACnet Object Type | BACnet Object ID | N2 Data Type | N2 Address | LonWorks Name | LonWorks SNVT |
| 1 | Com Status | BI | 1 | DI | 1 | nvoComStatus_XXX | SNVT_switch |
| 2 | Display Value | AI | 1 | AI | 1 | nvoDispVal_XXX | SNVT_count_f |
| 3 | Relay 1 Status | BV | 2 | DO | 2 | nvi/nvoRel1Stat_XXX | SNVT_switch |
| 4 | Relay 2 Status | BV | 3 | DO | 3 | nvi/nvoRel2Stat_XXX | SNVT_switch |
| 5 | Alarm 1 Status | BI | 4 | DI | 4 | nvoAlm1Stat_XXX | SNVT_switch |
| 6 | Alarm 2 Status | BI | 5 | DI | 5 | nvoAlm2Stat_XXX | SNVT_switch |
| 7 | Alarm 1 Acknowledge | BV | 6 | DO | 6 | nvi/nvoAlm1Ack_XXX | SNVT_switch |
| 8 | Alarm 2 Acknowledge | BV | 7 | DO | 7 | nvi/nvoAlm2Ack_XXX | SNVT_switch |
| 9 | Relay 1 Set Point | AV | 8 | AO | 8 | nvi/nvoR1SP_XXX | SNVT_count_f |
| 10 | Relay 1 Reset Point | AV | 9 | AO | 9 | nvi/nvoR1ResPt_XXX | SNVT_count_f |
| 11 | Relay 1 Turn-on Delay | AV | 10 | AO | 10 | nvi/nvoR1TnOnDI_XXX | SNVT_count_f |
| 12 | Relay 1 Turn-off Delay | AV | 11 | AO | 11 | nvi/nvoR1TnOfDI_XXX | SNVT_count_f |
| 13 | Relay 1 Normal/Fail-Safe | BV | 12 | DO | 12 | nvi/nvoR1NrFISf_XXX | SNVT_switch |
| 14 | Relay 1 Operation | AV | 13 | AO | 13 | nvi/nvoR1Oper_XXX | SNVT_count_f |
| 15 | Relay 2 Set Point | AV | 14 | AO | 14 | nvi/nvoR2SP_XXX | SNVT_count_f |
| 16 | Relay 2 Reset Point | AV | 15 | AO | 15 | nvi/nvoR2ResPt_XXX | SNVT_count_f |
| 17 | Relay 2 Turn-on Delay | AV | 16 | AO | 16 | nvi/nvoR2TnOnDI_XXX | SNVT_count_f |
| 18 | Relay 2 Turn-off Delay | AV | 17 | AO | 17 | nvi/nvoR2TnOfDI_XXX | SNVT_count_f |
| 19 | Relay 2 Normal/Fail-Safe | BV | 18 | DO | 18 | nvi/nvoR2NrFISf_XXX | SNVT_switch |
| 20 | Relay 2 Operation | AV | 19 | AO | 19 | nvi/nvoR2Oper_XXX | SNVT_count_f |
| 21 | 4-20mA Out-Mode Output Option | BV | 20 | DO | 20 | nvi/nvo420MdOtOp_XXX | SNVT_switch |
| 22 | 4-20mA Out-Mode Data Source | AV | 21 | AO | 21 | nvi/nvo420MdDtSr_XXX | SNVT_count_f |
| 23 | 4-20mA Out-Sensor Break Value | AV | 22 | AO | 22 | nvi/nvo420SnBkVI_XXX | SNVT_count_f |
| 24 | 4-20mA Out-Overrange value | AV | 23 | AO | 23 | nvi/nvo420OvrVal_XXX | SNVT_count_f |
| 25 | 4-20mA Out-Underrange value | AV | 24 | AO | 24 | nvi/nvo420UndVal_XXX | SNVT_count_f |
| 26 | 4-20mA Out-Max value Allowed | AV | 25 | AO | 25 | nvi/nvo420MxVIAI_XXX | SNVT_count_f |
| 27 | 4-20mA Out-Min value Allowed | AV | 26 | AO | 26 | nvi/nvo420MnVIAI_XXX | SNVT_count_f |
| 28 | 4-20mA Out-Display Value 1 | AV | 27 | AO | 27 | nvi/nvo420DspVI1_XXX | SNVT_count_f |
| 29 | 4-20mA Out-Display Value 2 | AV | 28 | AO | 28 | nvi/nvo420DspVI2_XXX | SNVT_count_f |
| 30 | 4-20mA Out-Output 1 | AV | 29 | AO | 29 | nvi/nvo420Output1_XXX | SNVT_count_f |
| 31 | 4-20mA Out-Output 2 | AV | 30 | AO | 30 | nvi/nvo420Output2_XXX | SNVT_count_f |
| 32 | 4-20mA Out-Data in mA or Data in bit | AV | 31 | AO | 31 | nvi/nvo420DtmABt_XXX | SNVT_count_f |

6 TROUBLESHOOTING

1. **Data received by BMS is all zeros or blank.** To fix, check the following:
 - a. Visual observations of LEDs on ProtoNode. [Section 6.1](#)
 - b. Check baud rate, parity, data bits, stop bits
 - c. Check Modbus device address
 - d. Verify wiring
 - e. Verify device is connected to the same subnet as the ProtoNode
 - f. Verify the Modbus device was discovered in Web Configurator Section 4

2. **BMS unable to see any points or devices.** To fix, check the following:
 - a. Visual dipswitch settings (using correct baud rate and device instance)
 - b. Verify IP address setting
 - c. Verify wiring

If the problem still exists, a Diagnostic Capture needs to be taken and sent to Bryan Steam. [Section 6.2](#)

6.1 LED DIAGNOSTICS FOR COMMUNICATIONS BETWEEN THE UCG AND DEVICES

Please see the diagram below for ProtoNode FPC-N34 and FPC-N35 LED Locations.

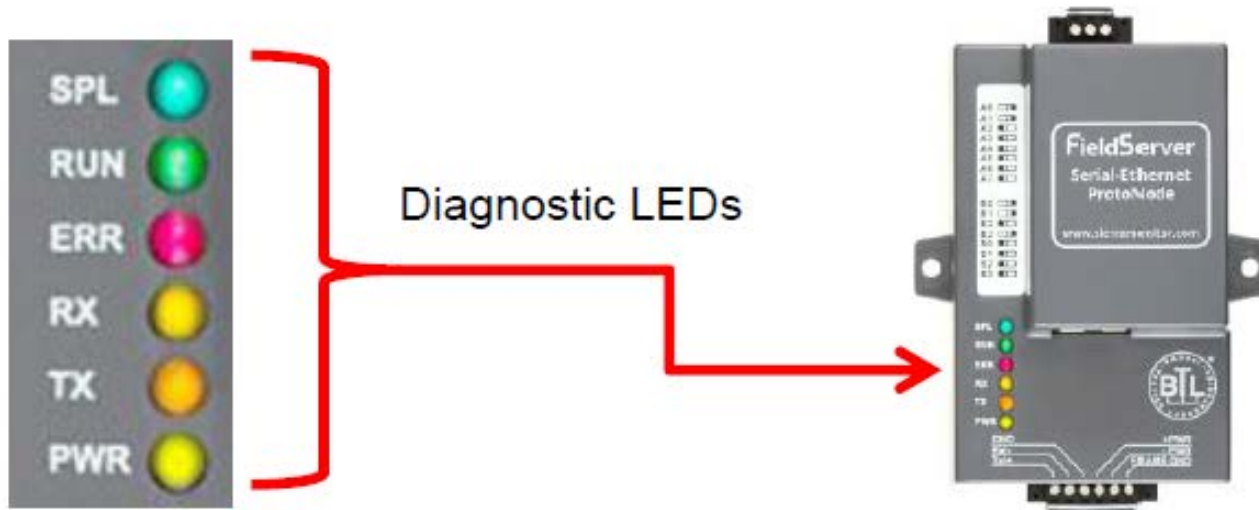

Figure 33 - Diagnostic LEDs

| Tag | Description |
|----------------|---|
| SPL (Blue) | The SPL LED will light if the unit is not getting a response from one or more of the configured devices. For LonWorks units , LED will light until the unit is commissioned on the LonWorks network. |
| RUN (Green) | The RUN LED will start flashing 20 seconds after power indicating normal operation. |
| ERR (Red) | The SYS ERR LED will go on solid 15 seconds after power up. It will turn off after 5 seconds. A steady red light will indicate there is a system error on the unit. If this occurs, immediately report the related “system error” shown in the error screen of the GUI interface to support for evaluation. |
| RX (Orange) | The RX LED will flash when a message is received on the host port. |
| TX (Yellow) | The TX LED will flash when a message is sent on the host port. |
| PWR (Green) | This is the power light and should show steady green at all times when ProtoNode is powered. |

Table 5 Diagnostic LEDs

6.2 TAKE DIAGNOSTIC CAPTURE WITH THE FIELDSEVER UTILITIES

1. Once the Diagnostic Capture is complete, email it to sales@bryansteam.com. The Diagnostic Capture will accelerate diagnosis of the problem.
2. Ensure that **FieldServer Toolbox** is loaded on the PC that is currently being used, or download FieldServer-Toolbox.zip on the Sierra Monitor webpage, under Customer Care: Resource Center, Software Downloads:
<http://www.sierramonitor.com/customer-care/resource-center?filters=software-downloads>
3. Extract the executable file and complete the installation.



4. Disable any wireless Ethernet adapters on the PC/Laptop.
5. Disable firewall and virus protection software if possible.
6. Connect a standard CAT5 Ethernet cable between the PC and ProtoNode.
7. Double click on the FS Toolbox Utility.
8. Step 1: Take a Log
 - a. Click on the diagnose icon  of the desired device

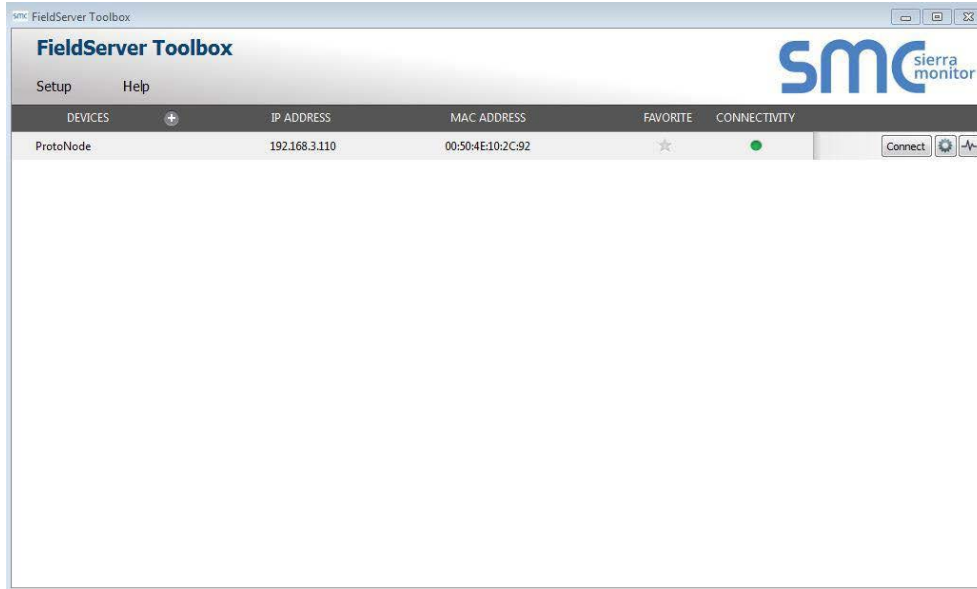

b. Select "Full Diagnostic"



NOTE: If desired, the default capture period can be changed

c. Click on "Start Diagnostic"

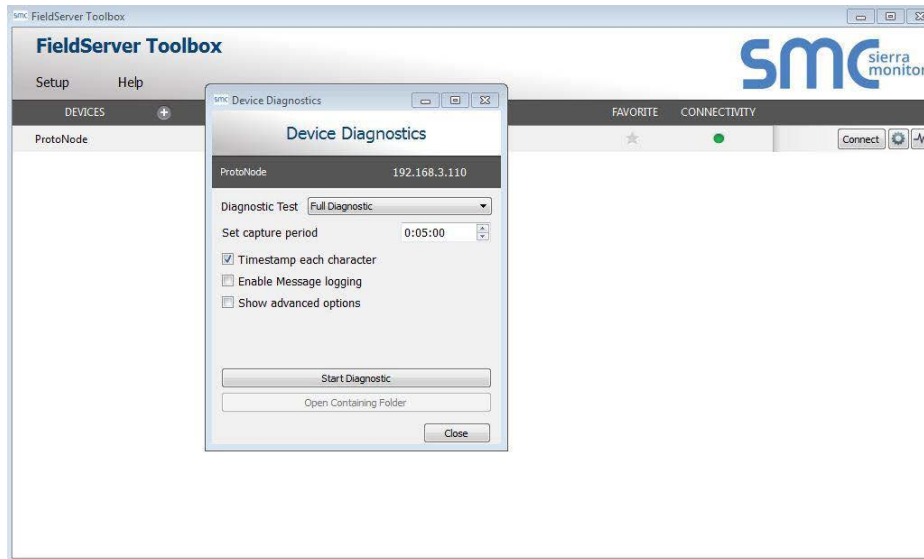

- d. When the capture period is finished, the “Diagnostic Test Complete” window will appear

9. Step 2: Send Log

- a. Once the diagnostic test is complete, a .zip file is saved on the PC

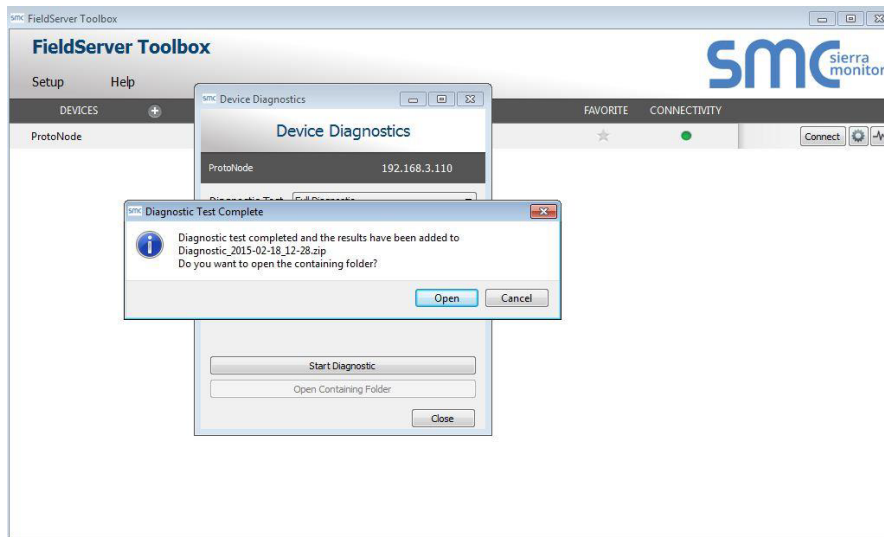

- b. Choose “Open” to launch explorer and have it point directly at the correct folder
- c. Send the Diagnostic zip file to sales@bryansteam.com



7 SPECIFICATIONS



| | Electrical Connections | |
|---|---|--------------------------|
| | BACnet/Metasys N2/Modbus TCP/IP | LonWorks |
| RJ45 | 10/100 Ethernet port | 10/100 Ethernet port |
| J1-1 | 120 Vac line voltage | 120 Vac line voltage |
| J1-2 | 120 Vac return voltage | 120 Vac return voltage |
| J1-3 | PE Ground | PE Ground |
| RJ45 | SOLA Port | SOLA Port |
| J3-3 | Device RS485 Data+ | Device RS485 Data+ |
| J3-2 | Device RS485 Data- | Device RS485 Data- |
| J3-1 | Device RS485 Ground | Device RS485 Ground |
| J2-3 | BMS RS485 Data+ | BMS FTT-10 LonWorks port |
| J2-2 | BMS RS485 Data- | BMS FTT-10 LonWorks port |
| J2-1 | BMS RS485 Ground | NA |
| Power Requirements | 120 Vac @ < 3.5 Watts | |
| Physical Dimensions | 10 in. x 12 in. x 6 in. | |
| Weight: | 13.2 lbs. | |
| Operating Temperature: | -40°C to 75°C (-40°F to 167°F) | |
| Surge Suppression | EN61000-4-2 ESD EN61000-4-3 EMC EN61000-4-4 EFT | |
| Humidity: | 5 - 90% RH (non-condensing) | |
| (Specifications subject to change without notice) | | |

Table 6 - Specifications

8 REFERENCE

8.1 WD857

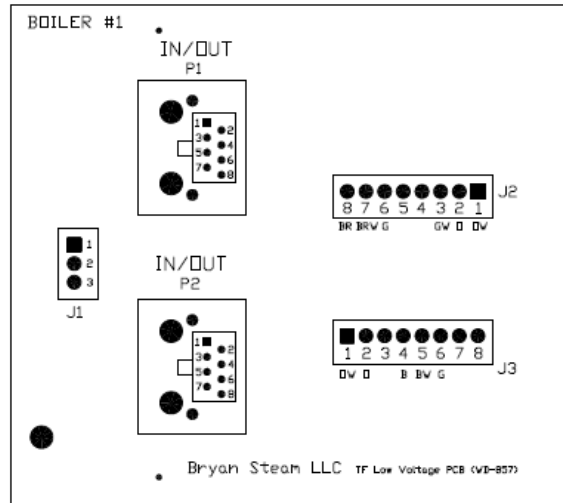

Figure 34 - WD-857 Printed Circuit Board

8.2 DEVICE RTU COM SETTINGS

| | Sola* | RWF40 | RWF55 | LMV3... | LMV5... | RM7800 |
|-----------|------------|------------|------------|------------|------------|------------|
| Protocol | Modbus RTU | Modbus RTU | Modbus RTU | Modbus RTU | Modbus RTU | Modbus RTU |
| Baud Rate | 38400 | 9600 | 9600 | 9600 | 9600 | 9600 |
| Parity | None | None | None | None | None | None |
| Data Bits | 8 | 8 | 8 | 8 | 8 | 8 |
| Stop Bits | 1 | 1 | 1 | 1 | 1 | 1 |

8.3 ADDRESS DIP SWITCH SETTINGS

| A7 | A6 | A5 | A4 | A3 | A2 | A1 | A0 | Address |
|-----|-----|-----|-----|-----|-----|-----|-----|---------|
| Off | Off | Off | Off | Off | Off | Off | Off | 0 |
| Off | Off | Off | Off | Off | Off | Off | On | 1 |
| Off | Off | Off | Off | Off | Off | On | Off | 2 |
| Off | Off | Off | Off | Off | Off | On | On | 3 |
| Off | Off | Off | Off | Off | On | Off | Off | 4 |
| Off | Off | Off | Off | Off | On | Off | On | 5 |
| Off | Off | Off | Off | Off | On | On | Off | 6 |
| Off | Off | Off | Off | Off | On | On | On | 7 |
| Off | Off | Off | Off | On | Off | Off | Off | 8 |
| Off | Off | Off | Off | On | Off | Off | On | 9 |
| Off | Off | Off | Off | On | Off | On | Off | 10 |
| Off | Off | Off | Off | On | Off | On | On | 11 |
| Off | Off | Off | Off | On | On | Off | Off | 12 |
| Off | Off | Off | Off | On | On | Off | On | 13 |
| Off | Off | Off | Off | On | On | On | Off | 14 |
| Off | Off | Off | Off | On | On | On | On | 15 |
| Off | Off | Off | On | Off | Off | Off | Off | 16 |
| Off | Off | Off | On | Off | Off | Off | On | 17 |
| Off | Off | Off | On | Off | Off | On | Off | 18 |
| Off | Off | Off | On | Off | Off | On | On | 19 |
| Off | Off | Off | On | Off | On | Off | Off | 20 |
| Off | Off | Off | On | Off | On | Off | On | 21 |
| Off | Off | Off | On | Off | On | On | Off | 22 |
| Off | Off | Off | On | Off | On | On | On | 23 |
| Off | Off | Off | On | On | Off | Off | Off | 24 |
| Off | Off | Off | On | On | Off | Off | On | 25 |
| Off | Off | Off | On | On | Off | On | Off | 26 |
| Off | Off | Off | On | On | Off | On | On | 27 |
| Off | Off | Off | On | On | On | Off | Off | 28 |
| Off | Off | Off | On | On | On | Off | On | 29 |
| Off | Off | Off | On | On | On | On | Off | 30 |
| Off | Off | Off | On | On | On | On | On | 31 |
| Off | Off | On | Off | Off | Off | Off | Off | 32 |
| Off | Off | On | Off | Off | Off | Off | On | 33 |
| Off | Off | On | Off | Off | Off | On | Off | 34 |
| Off | Off | On | Off | Off | Off | On | On | 35 |

| A7 | A6 | A5 | A4 | A3 | A2 | A1 | A0 | Address |
|-----|-----|-----|-----|-----|-----|-----|-----|---------|
| Off | Off | On | Off | Off | On | Off | Off | 36 |
| Off | Off | On | Off | Off | On | Off | On | 37 |
| Off | Off | On | Off | Off | On | On | Off | 38 |
| Off | Off | On | Off | Off | On | On | On | 39 |
| Off | Off | On | Off | On | Off | Off | Off | 40 |
| Off | Off | On | Off | On | Off | Off | On | 41 |
| Off | Off | On | Off | On | Off | On | Off | 42 |
| Off | Off | On | Off | On | Off | On | On | 43 |
| Off | Off | On | Off | On | On | Off | Off | 44 |
| Off | Off | On | Off | On | On | Off | On | 45 |
| Off | Off | On | Off | On | On | On | Off | 46 |
| Off | Off | On | Off | On | On | On | On | 47 |
| Off | Off | On | On | Off | Off | Off | Off | 48 |
| Off | Off | On | On | Off | Off | Off | On | 49 |
| Off | Off | On | On | Off | Off | On | Off | 50 |
| Off | Off | On | On | Off | Off | On | On | 51 |
| Off | Off | On | On | Off | On | Off | Off | 52 |
| Off | Off | On | On | Off | On | Off | On | 53 |
| Off | Off | On | On | Off | On | On | Off | 54 |
| Off | Off | On | On | Off | On | On | On | 55 |
| Off | Off | On | On | On | Off | Off | Off | 56 |
| Off | Off | On | On | On | Off | Off | On | 57 |
| Off | Off | On | On | On | Off | On | Off | 58 |
| Off | Off | On | On | On | Off | On | On | 59 |
| Off | Off | On | On | On | On | Off | Off | 60 |
| Off | Off | On | On | On | On | Off | On | 61 |
| Off | Off | On | On | On | On | On | Off | 62 |
| Off | Off | On | On | On | On | On | On | 63 |
| Off | On | Off | Off | Off | Off | Off | Off | 64 |
| Off | On | Off | Off | Off | Off | Off | On | 65 |
| Off | On | Off | Off | Off | Off | On | Off | 66 |
| Off | On | Off | Off | Off | Off | On | On | 67 |
| Off | On | Off | Off | Off | On | Off | Off | 68 |
| Off | On | Off | Off | Off | On | Off | On | 69 |
| Off | On | Off | Off | Off | On | On | Off | 70 |
| Off | On | Off | Off | Off | On | On | On | 71 |
| Off | On | Off | Off | On | Off | Off | Off | 72 |
| Off | On | Off | Off | On | Off | Off | On | 73 |

| A7 | A6 | A5 | A4 | A3 | A2 | A1 | A0 | Address |
|-----|----|-----|-----|-----|-----|-----|-----|---------|
| Off | On | Off | Off | On | Off | On | Off | 74 |
| Off | On | Off | Off | On | Off | On | On | 75 |
| Off | On | Off | Off | On | On | Off | Off | 76 |
| Off | On | Off | Off | On | On | Off | On | 77 |
| Off | On | Off | Off | On | On | On | Off | 78 |
| Off | On | Off | Off | On | On | On | On | 79 |
| Off | On | Off | On | Off | Off | Off | Off | 80 |
| Off | On | Off | On | Off | Off | Off | On | 81 |
| Off | On | Off | On | Off | Off | On | Off | 82 |
| Off | On | Off | On | Off | Off | On | On | 83 |
| Off | On | Off | On | Off | On | Off | Off | 84 |
| Off | On | Off | On | Off | On | Off | On | 85 |
| Off | On | Off | On | Off | On | On | Off | 86 |
| Off | On | Off | On | Off | On | On | On | 87 |
| Off | On | Off | On | On | Off | Off | Off | 88 |
| Off | On | Off | On | On | Off | Off | On | 89 |
| Off | On | Off | On | On | Off | On | Off | 90 |
| Off | On | Off | On | On | Off | On | On | 91 |
| Off | On | Off | On | On | On | Off | Off | 92 |
| Off | On | Off | On | On | On | Off | On | 93 |
| Off | On | Off | On | On | On | On | Off | 94 |
| Off | On | Off | On | On | On | On | On | 95 |
| Off | On | On | Off | Off | Off | Off | Off | 96 |
| Off | On | On | Off | Off | Off | Off | On | 97 |
| Off | On | On | Off | Off | Off | On | Off | 98 |
| Off | On | On | Off | Off | Off | On | On | 99 |
| Off | On | On | Off | Off | On | Off | Off | 100 |
| Off | On | On | Off | Off | On | Off | On | 101 |
| Off | On | On | Off | Off | On | On | Off | 102 |
| Off | On | On | Off | Off | On | On | On | 103 |
| Off | On | On | Off | On | Off | Off | Off | 104 |
| Off | On | On | Off | On | Off | Off | On | 105 |
| Off | On | On | Off | On | Off | On | Off | 106 |
| Off | On | On | Off | On | Off | On | On | 107 |
| Off | On | On | Off | On | On | Off | Off | 108 |
| Off | On | On | Off | On | On | Off | On | 109 |
| Off | On | On | Off | On | On | On | Off | 110 |
| Off | On | On | Off | On | On | On | On | 111 |

| A7 | A6 | A5 | A4 | A3 | A2 | A1 | A0 | Address |
|-----|-----|-----|-----|-----|-----|-----|-----|---------|
| Off | On | On | On | Off | Off | Off | Off | 112 |
| Off | On | On | On | Off | Off | Off | On | 113 |
| Off | On | On | On | Off | Off | On | Off | 114 |
| Off | On | On | On | Off | Off | On | On | 115 |
| Off | On | On | On | Off | On | Off | Off | 116 |
| Off | On | On | On | Off | On | Off | On | 117 |
| Off | On | On | On | Off | On | On | Off | 118 |
| Off | On | On | On | Off | On | On | On | 119 |
| Off | On | On | On | On | Off | Off | Off | 120 |
| Off | On | On | On | On | Off | Off | On | 121 |
| Off | On | On | On | On | Off | On | Off | 122 |
| Off | On | On | On | On | Off | On | On | 123 |
| Off | On | On | On | On | On | Off | Off | 124 |
| Off | On | On | On | On | On | Off | On | 125 |
| Off | On | On | On | On | On | On | Off | 126 |
| Off | On | On | On | On | On | On | On | 127 |
| On | Off | Off | Off | Off | Off | Off | Off | 128 |
| On | Off | Off | Off | Off | Off | Off | On | 129 |
| On | Off | Off | Off | Off | Off | On | Off | 130 |
| On | Off | Off | Off | Off | Off | On | On | 131 |
| On | Off | Off | Off | Off | On | Off | Off | 132 |
| On | Off | Off | Off | Off | On | Off | On | 133 |
| On | Off | Off | Off | Off | On | On | Off | 134 |
| On | Off | Off | Off | Off | On | On | On | 135 |
| On | Off | Off | Off | On | Off | Off | Off | 136 |
| On | Off | Off | Off | On | Off | Off | On | 137 |
| On | Off | Off | Off | On | Off | On | Off | 138 |
| On | Off | Off | Off | On | Off | On | On | 139 |
| On | Off | Off | Off | On | On | Off | Off | 140 |
| On | Off | Off | Off | On | On | Off | On | 141 |
| On | Off | Off | Off | On | On | On | Off | 142 |
| On | Off | Off | Off | On | On | On | On | 143 |
| On | Off | Off | On | Off | Off | Off | Off | 144 |
| On | Off | Off | On | Off | Off | Off | On | 145 |
| On | Off | Off | On | Off | Off | On | Off | 146 |
| On | Off | Off | On | Off | Off | On | On | 147 |
| On | Off | Off | On | Off | On | Off | Off | 148 |
| On | Off | Off | On | Off | On | Off | On | 149 |

| A7 | A6 | A5 | A4 | A3 | A2 | A1 | A0 | Address |
|----|-----|-----|-----|-----|-----|-----|-----|---------|
| On | Off | Off | On | Off | On | On | Off | 150 |
| On | Off | Off | On | Off | On | On | On | 151 |
| On | Off | Off | On | On | Off | Off | Off | 152 |
| On | Off | Off | On | On | Off | Off | On | 153 |
| On | Off | Off | On | On | Off | On | Off | 154 |
| On | Off | Off | On | On | Off | On | On | 155 |
| On | Off | Off | On | On | On | Off | Off | 156 |
| On | Off | Off | On | On | On | Off | On | 157 |
| On | Off | Off | On | On | On | On | Off | 158 |
| On | Off | Off | On | On | On | On | On | 159 |
| On | Off | On | Off | Off | Off | Off | Off | 160 |
| On | Off | On | Off | Off | Off | Off | On | 161 |
| On | Off | On | Off | Off | Off | On | Off | 162 |
| On | Off | On | Off | Off | Off | On | On | 163 |
| On | Off | On | Off | Off | On | Off | Off | 164 |
| On | Off | On | Off | Off | On | Off | On | 165 |
| On | Off | On | Off | Off | On | On | Off | 166 |
| On | Off | On | Off | Off | On | On | On | 167 |
| On | Off | On | Off | On | Off | Off | Off | 168 |
| On | Off | On | Off | On | Off | Off | On | 169 |
| On | Off | On | Off | On | Off | On | Off | 170 |
| On | Off | On | Off | On | Off | On | On | 171 |
| On | Off | On | Off | On | On | Off | Off | 172 |
| On | Off | On | Off | On | On | Off | On | 173 |
| On | Off | On | Off | On | On | On | Off | 174 |
| On | Off | On | Off | On | On | On | On | 175 |
| On | Off | On | On | Off | Off | Off | Off | 176 |
| On | Off | On | On | Off | Off | Off | On | 177 |
| On | Off | On | On | Off | Off | On | Off | 178 |
| On | Off | On | On | Off | Off | On | On | 179 |
| On | Off | On | On | Off | On | Off | Off | 180 |
| On | Off | On | On | Off | On | Off | On | 181 |
| On | Off | On | On | Off | On | On | Off | 182 |
| On | Off | On | On | Off | On | On | On | 183 |
| On | Off | On | On | On | Off | Off | Off | 184 |
| On | Off | On | On | On | Off | Off | On | 185 |
| On | Off | On | On | On | Off | On | Off | 186 |
| On | Off | On | On | On | Off | On | On | 187 |

| A7 | A6 | A5 | A4 | A3 | A2 | A1 | A0 | Address |
|----|-----|-----|-----|-----|-----|-----|-----|---------|
| On | Off | On | On | On | On | Off | Off | 188 |
| On | Off | On | On | On | On | Off | On | 189 |
| On | Off | On | On | On | On | On | Off | 190 |
| On | Off | On | On | On | On | On | On | 191 |
| On | On | Off | Off | Off | Off | Off | Off | 192 |
| On | On | Off | Off | Off | Off | Off | On | 193 |
| On | On | Off | Off | Off | Off | On | Off | 194 |
| On | On | Off | Off | Off | Off | On | On | 195 |
| On | On | Off | Off | Off | On | Off | Off | 196 |
| On | On | Off | Off | Off | On | Off | On | 197 |
| On | On | Off | Off | Off | On | On | Off | 198 |
| On | On | Off | Off | Off | On | On | On | 199 |
| On | On | Off | Off | On | Off | Off | Off | 200 |
| On | On | Off | Off | On | Off | Off | On | 201 |
| On | On | Off | Off | On | Off | On | Off | 202 |
| On | On | Off | Off | On | Off | On | On | 203 |
| On | On | Off | Off | On | On | Off | Off | 204 |
| On | On | Off | Off | On | On | Off | On | 205 |
| On | On | Off | Off | On | On | On | Off | 206 |
| On | On | Off | Off | On | On | On | On | 207 |
| On | On | Off | On | Off | Off | Off | Off | 208 |
| On | On | Off | On | Off | Off | Off | On | 209 |
| On | On | Off | On | Off | Off | On | Off | 210 |
| On | On | Off | On | Off | Off | On | On | 211 |
| On | On | Off | On | Off | On | Off | Off | 212 |
| On | On | Off | On | Off | On | Off | On | 213 |
| On | On | Off | On | Off | On | On | Off | 214 |
| On | On | Off | On | Off | On | On | On | 215 |
| On | On | Off | On | On | Off | Off | Off | 216 |
| On | On | Off | On | On | Off | Off | On | 217 |
| On | On | Off | On | On | Off | On | Off | 218 |
| On | On | Off | On | On | Off | On | On | 219 |
| On | On | Off | On | On | On | Off | Off | 220 |
| On | On | Off | On | On | On | Off | On | 221 |
| On | On | Off | On | On | On | On | Off | 222 |
| On | On | Off | On | On | On | On | On | 223 |
| On | On | On | Off | Off | Off | Off | Off | 224 |
| On | On | On | Off | Off | Off | Off | On | 225 |

| A7 | A6 | A5 | A4 | A3 | A2 | A1 | A0 | Address |
|----|----|----|-----|-----|-----|-----|-----|---------|
| On | On | On | Off | Off | Off | On | Off | 226 |
| On | On | On | Off | Off | Off | On | On | 227 |
| On | On | On | Off | Off | On | Off | Off | 228 |
| On | On | On | Off | Off | On | Off | On | 229 |
| On | On | On | Off | Off | On | On | Off | 230 |
| On | On | On | Off | Off | On | On | On | 231 |
| On | On | On | Off | On | Off | Off | Off | 232 |
| On | On | On | Off | On | Off | Off | On | 233 |
| On | On | On | Off | On | Off | On | Off | 234 |
| On | On | On | Off | On | Off | On | On | 235 |
| On | On | On | Off | On | On | Off | Off | 236 |
| On | On | On | Off | On | On | Off | On | 237 |
| On | On | On | Off | On | On | On | Off | 238 |
| On | On | On | Off | On | On | On | On | 239 |
| On | On | On | On | Off | Off | Off | Off | 240 |
| On | On | On | On | Off | Off | Off | On | 241 |
| On | On | On | On | Off | Off | On | Off | 242 |
| On | On | On | On | Off | Off | On | On | 243 |
| On | On | On | On | Off | On | Off | Off | 244 |
| On | On | On | On | Off | On | Off | On | 245 |
| On | On | On | On | Off | On | On | Off | 246 |
| On | On | On | On | Off | On | On | On | 247 |
| On | On | On | On | On | Off | Off | Off | 248 |
| On | On | On | On | On | Off | Off | On | 249 |
| On | On | On | On | On | Off | On | Off | 250 |
| On | On | On | On | On | Off | On | On | 251 |
| On | On | On | On | On | On | Off | Off | 252 |
| On | On | On | On | On | On | Off | On | 253 |
| On | On | On | On | On | On | On | Off | 254 |
| On | On | On | On | On | On | On | On | 255 |

9 INDEX

BACnet IP, 7, 12, 22, 23, 24, 25, 28, 31

BACnet MSTP, 12, 22, 23, 24, 28

Building Management

 Baud Rate, 22

Building Management. *See* Points Lists

Connections. *See* Wiring

Device Settings, 12

 Honeywell SOLA, 12

 Siemens LMV2.../LMV3..., 17

 Siemens LMV5..., 18

 Siemens RWF40, 14

 Siemens RWF55, 16

 UCG, 22

DIP switches, 22, 23, 24, 25, 28

Honeywell RM7800, 8, 12

Honeywell SOLA, 12

LMV2.../3.... *See* Siemens LMV2.../3...

LMV5.... *See* Siemens LMV5...

LonWorks, 22, 23, 26, 41

MAC Address, 23

Metasys N2, 22, 23, 25, 28, 41

Node ID, 23, 24

RM7800. *See* Honeywell RM7800

RWF40. *See* Siemens RWF40

RWF55. *See* Siemens RWF55

Siemens LMV2.../LMV3..., 8

Siemens LMV5..., 8, 12

Siemens RWF40, 9, 12

Siemens RWF55, 9, 12

Specifications, 41

Switches. *See* DIP Switches

Web Configurator, 27

Wiring

 Building Management, 7

 Device

 Boilers with WD-857 Circuit Board, 11

 End of Line Termination, 11

 Honeywell RM7800, 10

 Honeywell SOLA, 9

 Siemens LMV2.../LMV3..., 9

 Siemens LMV5..., 10

 Siemens RWF40, 9

 Siemens RWF55, 9