

BRYAN STEAM

Heat Exchanger Type Pool Heater

**Outputs from 200,000 to 4,200,000 BTUH Water Heat Source
and 400,000 to 3,600,000 BTUH Steam Heat Source**



Features:

- Completely packaged and assembled
- No gas or oil piping required
- No vent or chimney required
- Lower initial cost
- Less space required

All of the features and quality of the time proven Bryan “Indirect” Heaters are now available using an existing central boiler heating plant as the heat source.

Hot water or steam is taken from the heating main and circulated through the exchanger shell. The pool water is heated as it passes through the copper “Indirect” coil.

Standard Equipment

Steel heat exchanger shell — (125 PSI-ASME), copper heat exchanger with brass head, pool water temperature control aquastat to control heat source circulating pump or steam control valve, assembled and wired.

Optional Equipment

Circulating pump, steam control valve, thermometer, steam pressure gauge, steam strainer.

Note

1. Steam valve sizing based upon 5 PSI minimum steam pressure and ½ PSI return pressure.
2. Pump sizing based upon maximum temperature drop through exchanger of 30° F, and maximum head loss in piping between boiler and heater of 10 ft. H₂O. For other conditions and pressure drop data consult factory.

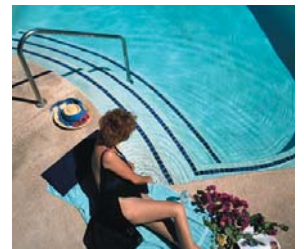

Bryan Heat Exchanger Type Pool Heater

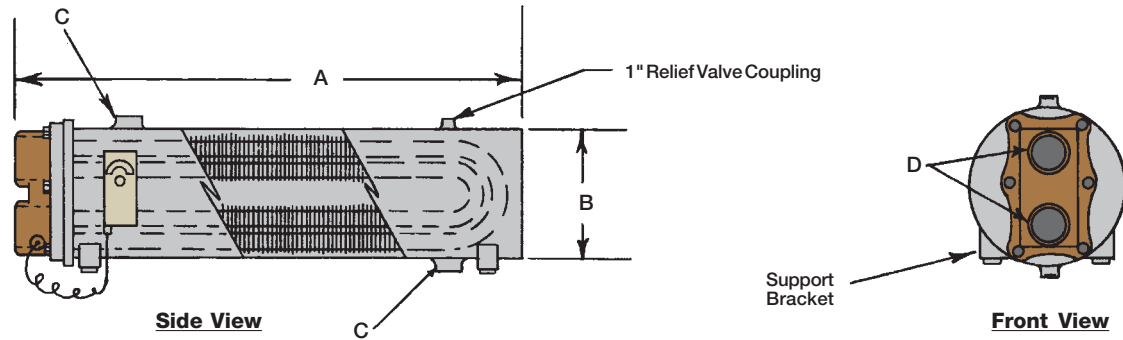

Water Heat Source

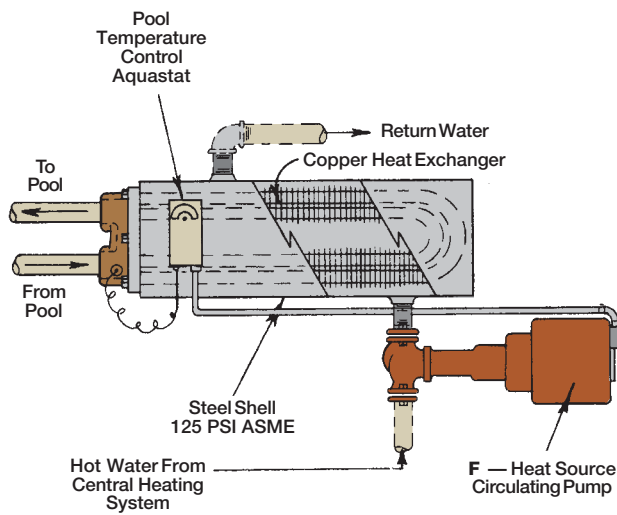

Steam Heat Source

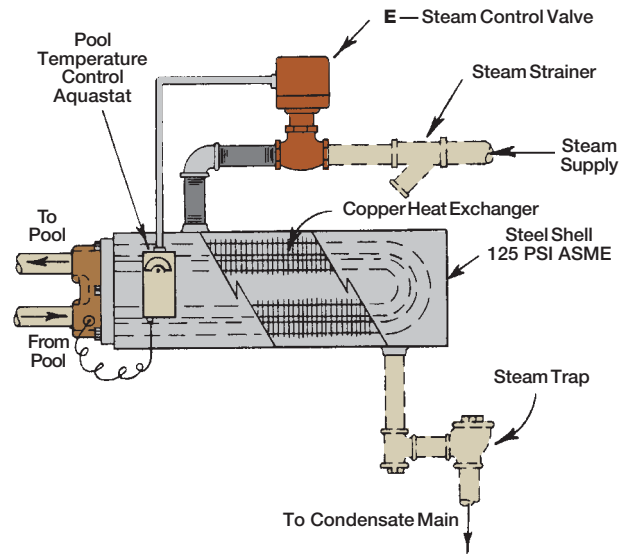

Heater Model	Heater Rating Output — BTU's per hr.				Standard Coil Model	Dimensions in. (cm)					Circulator				
	Heat Source					Length	Diameter	Shell Tappings	Pool Water Tappings	E Steam Valve-IPS (Pg.1, note1)	Max. Flow GPM Thru Shell	Shell ΔT	Circ. Model	F Size in. (cm) (Pg.1, note2)	Motor HP
	Water Temp.		Steam Pressure												
	180°	210°	2#	10#											
SH-16-15P	200,000	280,000	400,000	480,000	B2-16-15	20 (50.8)	11 (27.94)	2 (5.08)	2 (5.08)	1½ (3.81)	19	30°F	H-41	1 (2.54)	1/6
SH-16-32P	400,000	560,000	800,000	960,000	B2-16-32	37 (93.98)	11 (27.94)	2½ (6.35)	2 (5.08)	2 (5.08)	37	30°F	S-35	2 (5.08)	1/6
SH-24-32P	600,000	840,000	1,200,000	1,440,000	B2-24-32	37 (93.98)	11 (27.94)	2½ (6.35)	2 (5.08)	2½ (6.35)	56	30°F	S-45	2½ (6.35)	1/4
SH-24-42P	800,000	1,120,000	1,600,000	1,920,000	B2-24-42	47 (119.32)	11 (27.94)	2½ (6.35)	2 (5.08)	3 (7.62)	75	30°F	S-46	3 (7.62)	1/3
SH-24-54P	1,000,000	1,400,000	2,000,000	2,400,000	B2-24-54	59 (149.86)	11 (27.94)	2½ (6.35)	2 (5.08)	3 (7.62)	94	30°F	S-55	3 (7.62)	1/2
SH-40-48P	1,500,000	2,100,000	3,000,000	3,600,000	D2-40-51	56 (142.24)	13 (33.02)	3 (7.62)	2½ (6.35)	3 (7.62)	141	30°F	TV2g	3 (7.62)	1
SH-40-63P	2,000,000	2,800,000	—	—	D2-40-64	69 (175.26)	13 (33.02)	3 (7.62)	2½ (6.35)	—	187	30°F	TV2g	3 (7.62)	1
SH-40-77P	2,500,000	3,500,000	—	—	D2-40-78	83 (210.82)	13 (33.02)	3 (7.62)	2½ (6.35)	—	234	30°F	TV2g	3 (7.62)	1½
SH-40-99P	3,000,000	4,200,000	—	—	D2-40-99	105 (266.7)	13 (33.02)	3 (7.62)	2½ (6.35)	—	281	30°F	TV2g	5 (12.7)	2



Bryan Steam — Leaders Since 1916

783 N. Chili Ave., Peru, Indiana 46970 U.S.A.
 Phone: 765-473-6651 • Internet: www.bryanboilers.com
 Fax: 765-473-3074 • E-mail: bryanboilers@iquest.net