

BH Series Electric Boiler

150# Steam Design 510 kw to 3000 kw

EFFECTIVE: 9-19-06
REPLACED DATE: 4-19-05

- NOTES:
1. DIMENSIONS ARE SUBJECT TO CHANGE WITHOUT NOTICE. CONSULT FACTORY FOR CERTIFIED DIMENSIONS.
 2. TIE IN OF EXPANSION TANK CONNECTION IS ESSENTIAL TO INSURE PROPER OPERATION OF THE LOW WATER CUT-OFF FLOAT
 3. NOT INTENDED FOR USE AS A PRINCIPAL HEATING SOURCE FOR LIVING SPACE OF AN INDIVIDUAL RESIDENCE

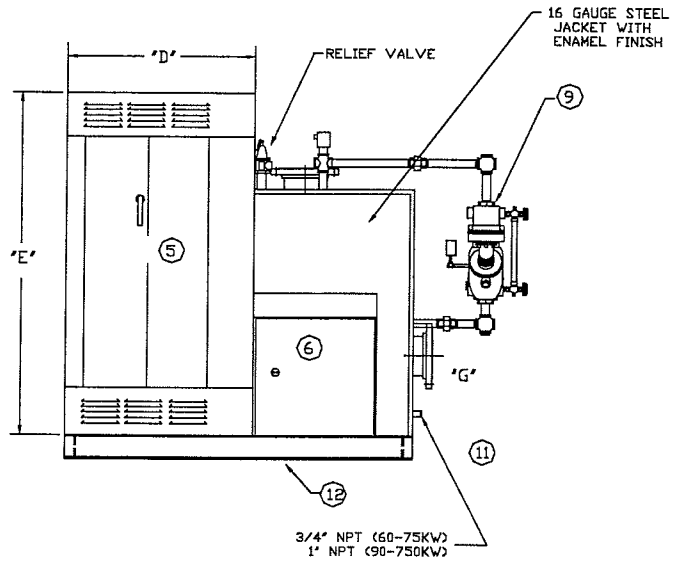
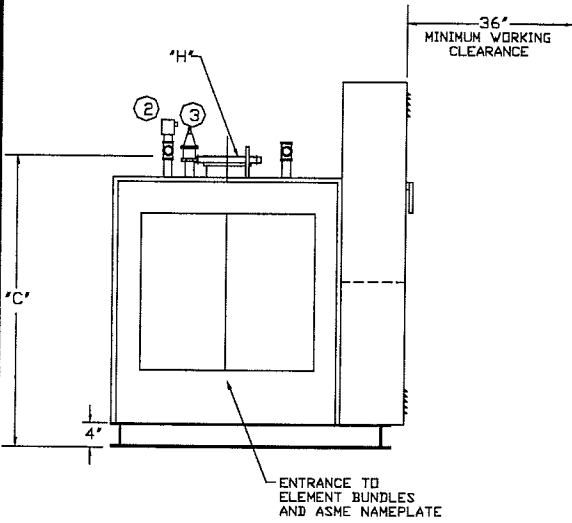
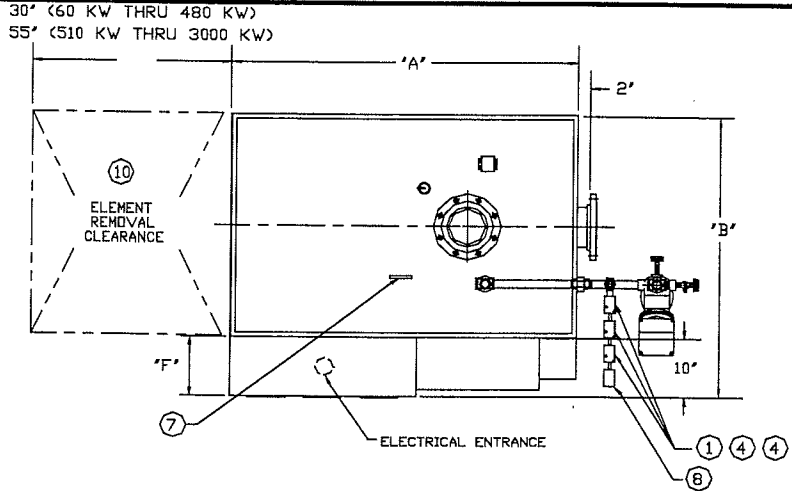

- | | | |
|--------------------|-------------------|---------------------------|
| 1. OPERATOR | 5. POWER PANEL | 9. LWCO/PUMP CONTROL |
| 2. PROBE TYPE LWCO | 6. CONTROL PANEL | 10. ELEMENT ACCESS |
| 3. RELIEF VALVE | 7. LIFTING LUGS | 11. DRAIN |
| 4. PRESSURE RETROL | 8. PRESSURE GAUGE | 12. STRUCTURAL STEEL BASE |

KW	Dimensions			DxExF	DxExF	Inlet		Outlet	
	A	B	C			G	H		
				208-230/3/60	460-575/3/60				
510	**	**	**	N/A	36"x72"x10"	**	**		
540	**	**	**	N/A	36"x72"x10"	**	**		
570	**	**	**	N/A	36"x72"x10"	**	**		
600	**	**	**	N/A	36"x72"x10"	**	**		
660	**	**	**	N/A	36"x72"x10"	**	**		
720	**	**	**	N/A	36"x72"x10"	**	**		
780	**	**	**	N/A	60"x82"x16"	**	**		
840	**	**	**	N/A	60"x82"x16"	**	**		
900	**	**	**	N/A	60"x82"x16"	**	**		
960	**	**	**	N/A	60"x82"x16"	**	**		
1020	**	**	**	N/A	60"x82"x16"	**	**		
1080	**	**	**	N/A	60"x82"x16"	**	**		

KW	Dimensions			DxExF	DxExF	Inlet		Outlet	
	A	B	C			G	H		
				208-230/3/60	460-575/3/60				
1140	**	**	**	N/A	**	**	**		
1200	**	**	**	N/A	**	**	**		
1260	**	**	**	N/A	**	**	**		
1320	**	**	**	N/A	**	**	**		
1380	**	**	**	N/A	**	**	**		
1440	**	**	**	N/A	**	**	**		
1530	**	**	**	N/A	**	**	**		
1620	**	**	**	N/A	**	**	**		
1710	**	**	**	N/A	**	**	**		
1800	**	**	**	N/A	**	**	**		
1920	**	**	**	N/A	**	**	**		
2040-3000	**	**	**	N/A	**	**	**		

** CONSULT FACTORY

BRYAN BOILERS

783 NORTH CHILI AVE
PERU, INDIANA 46970

FORM NO.:

2252

BH-Q Series Electric Steam Boiler

KW	MBH Input	MBH Output	BHP	Element Density	208/3/60 Amps	240/3/60 Amps	380/3/60 Amps	480/360 Amps	Ship Wt.
510	1785	1671	51.0	75 watts	1417	1228	776	614	2900
540	1890	1769	54.0	75 watts	1501	1301	821	650	3000
570	1995	1867	57.0	75 watts	1584	1373	867	686	3400
600	2100	1966	60.0	75 watts	1667	1445	913	723	3500
660	2310	2162	66.0	75 watts	1834	1590	1004	795	3600
720	2520	2359	72.0	75 watts	2001	1734	1095	867	3800
780	2730	2555	78.0	75 watts	2168	1879	1186	939	4000
840	2940	2752	84.0	75 watts	2334	2023	1278	1012	4100
900	3150	2948	90.0	75 watts	2501	2168	1369	1084	4200
960	3360	3145	96.0	75 watts	2668	2312	1460	1156	4400
1020	3570	3342	102.0	75 watts	2835	2457	1552	1228	5000
1080	3780	3538	108.0	75 watts	3001	2601	1643	1301	5100
1140	3990	3735	114.0	75 watts	3168	2746	1734	1373	5500
1200	4200	3931	120.0	75 watts	3335	2890	1825	1445	5700
1260	4410	4128	126.0	75 watts	3502	3035	1917	1517	6000
1320	4620	4324	132.0	75 watts	3668	3179	2008	1590	6100
1380	4830	4521	138.0	75 watts	3835	3324	2099	1662	6300
1440	5040	4717	144.0	75 watts	4002	3468	2190	1734	6400
1530	5355	5012	153.0	75 watts	4252	3685	2327	1842	6600
1620	5670	5307	162.0	75 watts	4502	3902	2464	1951	6800
1650	5775	5405	165.0	75 watts	4585	3974	2510	1987	7000

KW	Fluid Cap.	Operating Wt.	Inlet sizes		125# outlet sizes		150# Capacity		
			Relief size	Capacity MBH	Relief size	Capacity MBH			
510	160	4228	2" 150# flg	4" 150# flg	(2) 3/4"	2800	(2) 3/4"	3302	
540	160	4328	2" 150# flg	4" 150# flg	(2) 3/4"	2800	(2) 3/4"	3302	
570	160	4728	2" 150# flg	4" 150# flg	(2) 3/4"	2800	(2) 3/4"	3302	
600	160	4828	2" 150# flg	4" 150# flg	(2) 3/4"	2800	(2) 3/4"	3302	
660	255	5717	2" 150# flg	4" 150# flg	(2) 3/4"	2800	(2) 3/4"	3302	
720	255	5917	2" 150# flg	4" 150# flg	(2) 3/4"	2800	(2) 3/4"	3302	
780	255	6117	2" 150# flg	4" 150# flg	(2) 3/4"	2800	(2) 3/4"	3302	
840	255	6217	2" 150# flg	4" 150# flg	(2) 1"	4380	(2) 3/4"	3302	
900	255	6317	2" 150# flg	4" 150# flg	(2) 1"	4380	(2) 3/4"	3302	
960	352	7322	2" 150# flg	6" 150# flg	(2) 1"	4380	(2) 1"	5166	
1020	352	7922	2" 150# flg	6" 150# flg	(2) 1"	4380	(2) 1"	5166	
1080	473	9026	2" 150# flg	6" 150# flg	(2) 1"	4380	(2) 1"	5166	
1140	473	9426	2" 150# flg	6" 150# flg	(3) 1"	6570	(2) 1"	5166	
1200	473	9626	2" 150# flg	6" 150# flg	(3) 1"	6570	(2) 1"	5166	
1260	473	9926	2" 150# flg	6" 150# flg	(3) 1"	6570	(2) 1"	5166	
1320	473	10026	2" 150# flg	6" 150# flg	(3) 1"	6570	(2) 1"	5166	
1380	473	10226	2" 150# flg	6" 150# flg	(3) 1"	6570	(2) 1"	5166	
1440	473	10326	2" 150# flg	6" 150# flg	(3) 1"	6570	(2) 1"	5166	
1530	473	10526	2" 150# flg	6" 150# flg	(3) 1"	6570	(2) 1-1/4"	7180	
1620	473	10726	2" 150# flg	6" 150# flg	(3) 1"	6570	(2) 1-1/4"	7180	
1650	473	10926	2" 150# flg	6" 150# flg	(3) 1"	6570	(2) 1-1/4"	7180	