

HE-AB SERIES FORCED DRAFT HIGH EFFICIENCY WATER BOILER
(HE-AB90 THRU HE-AB300)

EFFECTIVE DATE: 3/9/09
REPLACES: 11/8/06

NOTES:

1. ALL DIMENSIONS ARE IN INCHES THOSE IN PARENTHESES ARE CENTIMETERS.
2. LOCATION DIMENSIONS ARE ALL $\pm 1/2"$.
3. GAS TRAIN, CONTROL AND BURNER CONFIGURATION WILL VARY DEPENDING ON JOB SPECIFICATIONS & CONDITIONS.
4. DIMENSIONS ARE SUBJECT TO CHANGE WITHOUT NOTICE. CONSULT FACTORY FOR CERTIFIED DIMENSIONS.
5. ALL FLANGES ARE 150# UNLESS OTHERWISE NOTED, FLANGES TO STRADDLE CENTER LINE.
6. AB 90 THRU AB 150 WILL HAVE ONLY (1) LIFT LUG. AB 200 THRU AB 300 WILL HAVE (2) LIFT LUGS.

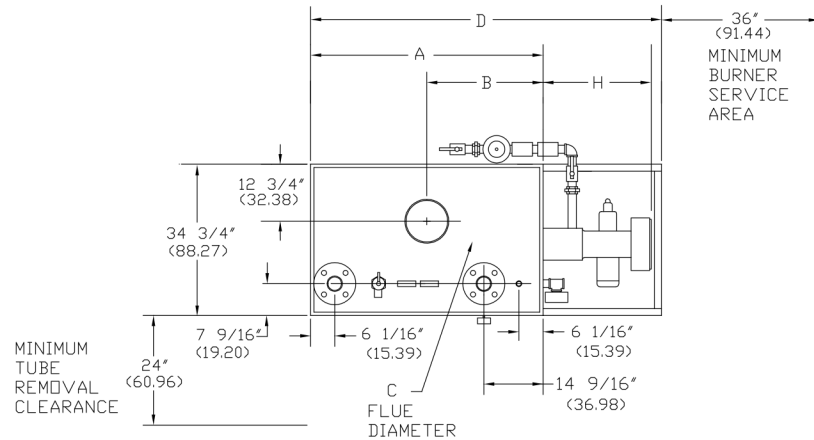

PLAN VIEW

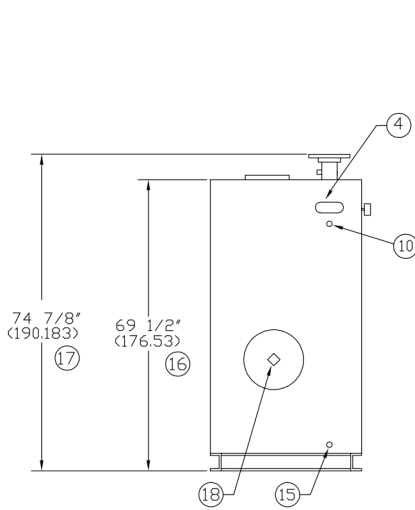

REAR VIEW

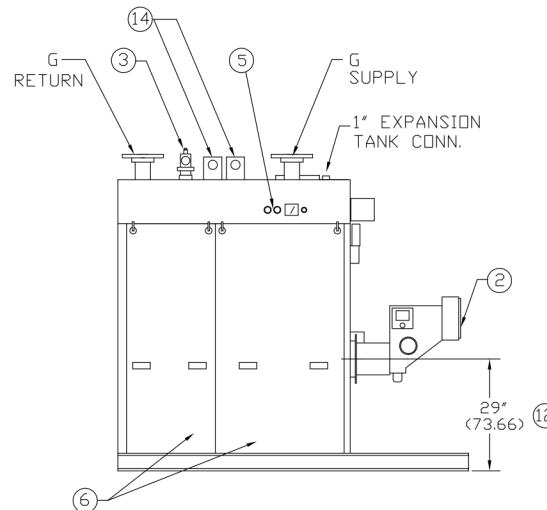

LEFT SIDE VIEW

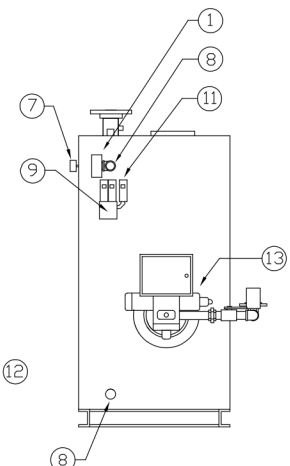

FRONT VIEW

- | | | | |
|-------------------------|----------------------------------|---------------------------------|----------------------------|
| 1. PROBE TYPE L.W.C.D.- | 6. JACKET ACCESS PANELS | 11. AQUASTATS | 16. HEIGHT OVER JACKET |
| 2. FORCED DRAFT BURNER | 7. PRESS./TEMP. GAUGE | 12. BURNER CENTER LINE | 17. HEIGHT OVER SUPPLY |
| 3. RELIEF VALVE | 8. CLNDUT./INSP. OPNG.-1 1/2"NPT | 13. OIL PUMP LOCATION | 18. FLAME OBSERVATION PORT |
| 4. ASME NAMEPLATE | 9. ELEC. ENCLOSURE- | 14. LIFTING LUG(S) (SEE NOTE 6) | 19. |
| 5. CONTROL CONNECTION | 10. AUX. CONNECTION 1 1/4" NPT | 15. DRAIN CONNECTION | 20. |

BOILER MODEL	HE-AB 90	HE-AB 120	HE-AB 150	HE-AB 200	HE-AB 250	HE-AB 300
A-LENGTH OVER JACKET	44 15/16" (114.14)	54 3/16" (137.63)	63 1/2" (161.29)	78 15/16" (200.5)	94 7/16" (239.87)	108 13/16" (276.38)
B-FLUE LOCATION	22 1/2" (57.15)	27 1/16" (68.73)	31 3/4" (80.64)	39 1/2" (100.33)	47 1/4" (120.01)	54 3/8" (138.11)
C-FLUE DIAMETER	10" (25.40)	10" (25.40)	10" (25.40)	10" (25.40)	12" (30.48)	12" (30.48)
D-LENGTH OVER BASE	76" (193.04)	85 3/8" (216.83)	94 3/4" (240.67)	110" (279.40)	125 1/2" (318.77)	139 7/8" (355.28)
G-SUPPLY/RETURN NOZZLE SIZE	3" (7.62)	3" (7.62)	3" (7.62)	3" (7.62)	3" (7.62)	3" (7.62)
H-BURNER EXTENSION	CONSULT FACTORY FOR BURNER EXTENSION APPLICATIONS					



783 NORTH CHILI AVE
PERU, INDIANA 46970

ORDER NO.:
ORDER REV. NO.:
FORM NO.: 2369

HE-AB SERIES FORCED DRAFT WATER BOILER

BOILER MODEL		HE-AB90	HE-AB120	HE-AB150	HE-AB200	HE-AB250	HE-AB300
INPUT	MBH	900	1,200	1,500	2,000	2,500	3,000
	(KW)	263.7	351.6	439.5	586.0	732.5	879.0
OUTPUT*	MBH	765	1,020	1,275	1,700	2,125	2,550
	(KW)	224.1	298.9	373.6	498.1	622.6	747.1
BOILER HORSEPOWER*	HP	23	30	38	51	63	76
	(KW)	224	299	373	498	622	747
TUBE DIAMETER	INCHES	1.00	1.00	1.00	1.00	1.00	1.00
	(CM)	2.54	2.54	2.54	2.54	2.54	2.54
NUMBER OF TUBES		26	35	44	59	74	88
PRESSURE VESSEL							
VOLUME	GAL	36	44	53	69	83	111
	(L)	136.3	166.5	200.6	261.2	314.2	420.1
HEATING SURFACE	SQ FT	161	215	269	364	461	534
	(SQ M)	15.0	20.0	25.0	33.8	42.8	49.6
OPERATING WEIGHT	LBS	2,564	2,936	3,392	4,125	4,792	5,505
	(KG)	1,163.0	1,331.8	1,538.6	1,871.1	2,173.7	2,497.1
SHIPPING WEIGHT	LBS	2,105	2,390	2,725	3,295	3,815	4,100
	(KG)	954.8	1,084.1	1,236.1	1,494.6	1,730.5	1,859.8

* Output and Boiler HP based on an average natural gas combustion efficiency.