

BRYAN STEAM

U-Tube Heat Exchangers **UW-Series, Water to Water**



Bryan's Water to Water Heat Exchangers are built to offer long life and maximum performance in all applications, including service water, space heating, radiation, swimming pool heating and various process applications.

These instantaneous heaters operate with water on the shellside and water on the tubeside. Bryan offers U-Tube Heat Exchangers in sizes ranging from 4" diameter to 12" diameter and lengths up to 10', in both two and four-pass designs.

Material of construction

Heads:	Cast Iron
Tube sheets:	Steel
Shell:	Steel
Baffles:	Steel
Bolting:	Steel
Tubes:	3/4" O. D. copper

Units are available with optional materials of construction, such as brass, copper, cupro-nickel or other alloys as specified.

Rating of Standard Units				
Shell Diam.	Maximum Pressure			Maximum Operating Temperature
	Tubes		Shell	
	2 pass	4 pass		
4"	150 psi	150 psi	150 psi	375°F
6"	150 psi	150 psi	150 psi	375°F
8"	150 psi	150 psi	150 psi	375°F
10"	125 psi	150 psi	150 psi	375°F
12"	125 psi	150 psi	150 psi	375°F

Consult factory for working pressure and temperature higher than standard, as well as changes resulting from differences in optional construction materials.

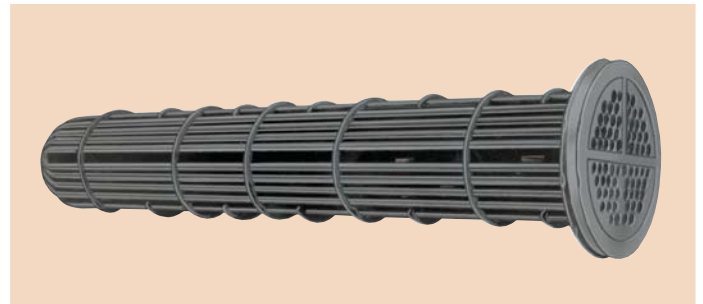

Bryan Steam — Leaders Since 1916

783 N. Chili Ave., Peru, Indiana 46970 U.S.A.
Phone: 765-473-6651 • Internet: www.bryanboilers.com
Fax: 765-473-3074 • E-mail: bryanboilers@iquest.net

Bryan Water to Water Heat Exchanger

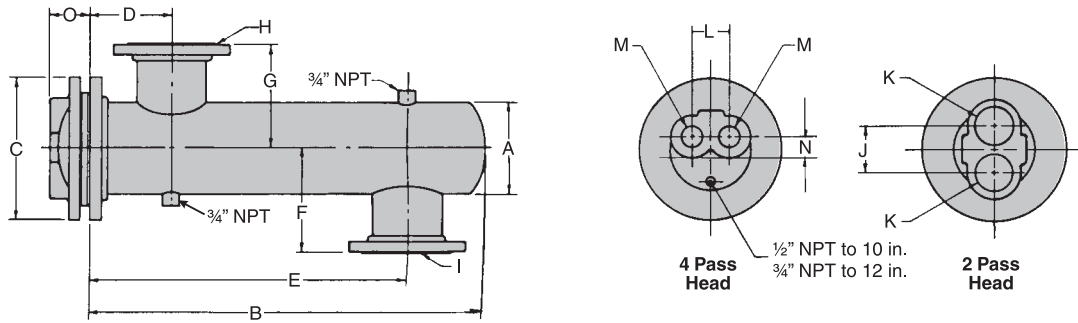

Model Number		Dimensions (inches)															Heating Surface (sq. ft.)	Shipping Weight (lbs.)
2 Pass	4 Pass	2 and 4 Pass									2 Pass		4 Pass					
4 Inch Diameter		A	B	C	D	E	F	G	H	I	J	K	L	M	N	O		
UW4-2-2	UW4-2-4	4½	24½	9	5	19½	4¾	4¾	1½T	1½T	2½	1¼T	2¾	1T	7/8	27/8	4.6	65
UW4-3-2	UW4-3-4	4½	36½	9	5	31½	4¾	4¾	1½T	1½T	2½	1¼T	2¾	1T	7/8	27/8	7.0	75
UW4-4-2	UW4-4-4	4½	48½	9	5	43½	4¾	4¾	1½T	1½T	2½	1¼T	2¾	1T	7/8	27/8	9.3	84
UW4-5-2	UW4-5-4	4½	60½	9	5	55½	4¾	4¾	1½T	1½T	2½	1¼T	2¾	1T	7/8	27/8	11.7	94
UW4-6-2	UW4-6-4	4½	72½	9	5	67½	4¾	4¾	1½T	1½T	2½	1¼T	2¾	1T	7/8	27/8	14.1	104
UW4-7-2	UW4-7-4	4½	84½	9	5	79½	4¾	4¾	1½T	1½T	2½	1¼T	2¾	1T	7/8	27/8	16.4	114
UW4-8-2	UW4-8-4	4½	96½	9	5	91½	4¾	4¾	1½T	1½T	2½	1¼T	2¾	1T	7/8	27/8	18.8	124
UW4-9-2	UW4-9-4	4½	108½	9	5	103½	4¾	4¾	1½T	1½T	2½	1¼T	2¾	1T	7/8	27/8	21.1	134
UW4-10-2	UW4-10-4	4½	120½	9	5	115½	4¾	4¾	1½T	1½T	2½	1¼T	2¾	1T	7/8	27/8	23.5	144
6 Inch Diameter																		
UW6-2-2	UW6-2-4	6⅝	25	11	5	18½	47/8	47/8	2½T	2½T	4	2T	3¾	1½T	1¼	37/16	9.1	120
UW6-3-2	UW6-3-4	6⅝	37	11	5	30½	47/8	47/8	2½T	2½T	4	2T	3¾	1½T	1¼	37/16	13.8	148
UW6-4-2	UW6-4-4	6⅝	49	11	5	42½	47/8	47/8	2½T	2½T	4	2T	3¾	1½T	1¼	37/16	18.5	182
UW6-5-2	UW6-5-4	6⅝	61	11	5	54½	47/8	47/8	2½T	2½T	4	2T	3¾	1½T	1¼	37/16	23.2	207
UW6-6-2	UW6-6-4	6⅝	73	11	5	66½	47/8	47/8	2½T	2½T	4	2T	3¾	1½T	1¼	37/16	27.9	235
UW6-7-2	UW6-7-4	6⅝	85	11	5	78½	47/8	47/8	2½T	2½T	4	2T	3¾	1½T	1¼	37/16	32.6	262
UW6-8-2	UW6-8-4	6⅝	97	11	5	90½	47/8	47/8	2½T	2½T	4	2T	3¾	1½T	1¼	37/16	37.3	290
UW6-9-2	UW6-9-4	6⅝	109	11	5	102½	47/8	47/8	2½T	2½T	4	2T	3¾	1½T	1¼	37/16	42.1	318
UW6-10-2	UW6-10-4	6⅝	121	11	5	114½	47/8	47/8	2½T	2½T	4	2T	3¾	1½T	1¼	37/16	46.8	346
8 Inch Diameter																		
UW8-2-2	UW8-2-4	8⅝	26¼	13½	7	18	8⅞	8⅞	3T	3T	4½	3T	4½	2T	1½	37/8	16.5	192
UW8-3-2	UW8-3-4	8⅝	38¼	13½	7	30	8⅞	8⅞	3T	3T	4½	3T	4½	2T	1½	37/8	25.1	234
UW8-4-2	UW8-4-4	8⅝	50¼	13½	7	42	8⅞	8⅞	3T	3T	4½	3T	4½	2T	1½	37/8	33.7	283
UW8-5-2	UW8-5-4	8⅝	62¼	13½	7	54	8⅞	8⅞	3T	3T	4½	3T	4½	2T	1½	37/8	42.4	326
UW8-6-2	UW8-6-4	8⅝	74¼	13½	7	66	8⅞	8⅞	3T	3T	4½	3T	4½	2T	1½	37/8	51.0	369
UW8-7-2	UW8-7-4	8⅝	86¼	13½	7	78	8⅞	8⅞	3T	3T	4½	3T	4½	2T	1½	37/8	59.7	390
UW8-8-2	UW8-8-4	8⅝	98¼	13½	7	90	8⅞	8⅞	3T	3T	4½	3T	4½	2T	1½	37/8	68.3	453
UW8-9-2	UW8-9-4	8⅝	110¼	13½	7	102	8⅞	8⅞	3T	3T	4½	3T	4½	2T	1½	37/8	76.9	496
UW8-10-2	UW8-10-4	8⅝	122¼	13½	7	114	8⅞	8⅞	3T	3T	4½	3T	4½	2T	1½	37/8	85.6	540
10 Inch Diameter																		
UW10-2-2	UW10-2-4	10¾	27¼	16	7	18	10⅜	10⅜	4F	4F	6¼	4T	5¼	3T	2	51/16	26.8	300
UW10-3-2	UW10-3-4	10¾	38¼	16	7	29	10⅜	10⅜	4F	4F	6¼	4T	5¼	3T	2	51/16	40.9	353
UW10-4-2	UW10-4-4	10¾	49¼	16	7	40	10⅜	10⅜	4F	4F	6¼	4T	5¼	3T	2	51/16	55.0	415
UW10-5-2	UW10-5-4	10¾	62¼	16	7	53	10⅜	10⅜	4F	4F	6¼	4T	5¼	3T	2	51/16	69.2	476
UW10-6-2	UW10-6-4	10¾	74¼	16	7	65	10⅜	10⅜	4F	4F	6¼	4T	5¼	3T	2	51/16	83.3	537
UW10-7-2	UW10-7-4	10¾	85¼	16	7	76	10⅜	10⅜	4F	4F	6¼	4T	5¼	3T	2	51/16	97.5	598
UW10-8-2	UW10-8-4	10¾	98¼	16	7	89	10⅜	10⅜	4F	4F	6¼	4T	5¼	3T	2	51/16	111.6	660
UW10-9-2	UW10-9-4	10¾	110¼	16	7	101	10⅜	10⅜	4F	4F	6¼	4T	5¼	3T	2	51/16	125.7	721
UW10-10-2	UW10-10-4	10¾	122¼	16	7	113	10⅜	10⅜	4F	4F	6¼	4T	5¼	3T	2	51/16	139.9	782
12 Inch Diameter																		
UW12-3-2	UW12-3-4	12¾	48¼	19	8	38¼	11⅜	11⅜	5F	5F	8	4T	57/8	3T	2½	59/16	58.6	510
UW12-4-2	UW12-4-4	12¾	60¼	19	8	50¼	11⅜	11⅜	5F	5F	8	4T	57/8	3T	2½	59/16	79.0	596
UW12-5-2	UW12-5-4	12¾	72¼	19	8	62¼	11⅜	11⅜	5F	5F	8	4T	57/8	3T	2½	59/16	99.5	681
UW12-6-2	UW12-6-4	12¾	84¼	19	8	74¼	11⅜	11⅜	5F	5F	8	4T	57/8	3T	2½	59/16	119.9	772
UW12-7-2	UW12-7-4	12¾	96¼	19	8	86¼	11⅜	11⅜	5F	5F	8	4T	57/8	3T	2½	59/16	140.3	857
UW12-8-2	UW12-8-4	12¾	108¼	19	8	98¼	11⅜	11⅜	5F	5F	8	4T	57/8	3T	2½	59/16	160.8	941
UW12-9-2	UW12-9-4	12¾	120¼	19	8	110¼	11⅜	11⅜	5F	5F	8	4T	57/8	3T	2½	59/16	181.2	1027
UW12-10-2	UW12-10-4	12¾	132¼	19	8	122¼	11⅜	11⅜	5F	5F	8	4T	57/8	3T	2½	59/16	201.6	1111

NOTE: Dimensions and specifications are subject to change without notice. Consult factory for certified dimensions.