

FREE FLEX

High Efficiency, Low Emission, Condensing Water Boiler

INSTALLATION & OPERATION MANUAL: MODELS 1000-6000

Save this manual for future reference.



Intertek

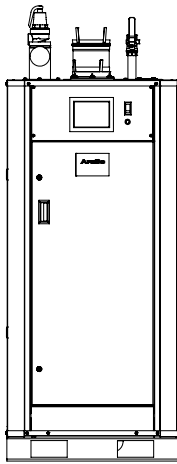

1000

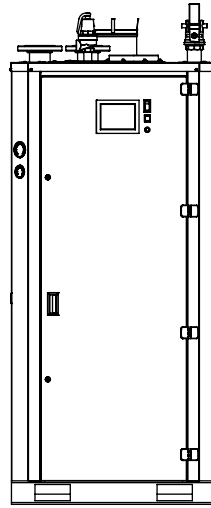

1500-3000

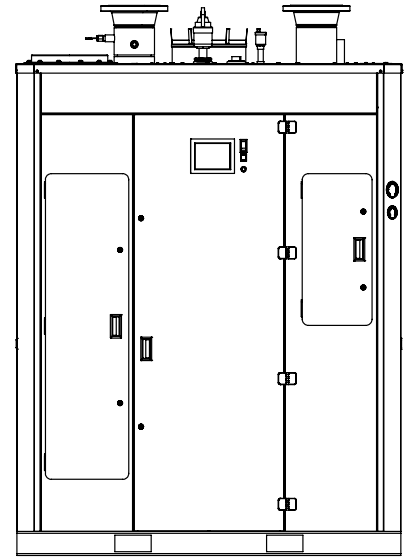

3500-6000

⚠ WARNING

Asphyxiation Hazard. Fire Hazard. Explosion Hazard.

This appliance must be installed, serviced or repaired by a skilled and experienced service technician. Improper installation, adjustment, alteration, service or maintenance can cause severe personal injury, death, or substantial property damage. Read and understand these instructions and entire boiler manual before attempting to service boiler. Up to date boiler manual is posted on manufacturer's website.

⚠ DANGER

Explosion Hazard. Electrical Shock Hazard. Burn Hazard.

Flammable gas, high voltage electricity, moving parts, and very hot water under high pressure. Assure that all gas and electric power supplies are off and that water temperature is cool before attempting any disassembly or service. Do not rely solely on temperature/pressure gauge to make this determination.

Boiler Model:
Serial Number:
Heating Contractor:
Installation date:



Table of Contents

I. Introduction	5		
A. Important Information	5	D. Power the Circulators	38
B. Disclaimers and Local Codes	5	E. Pressurize the Fuel System	38
C. Test and Inspections	5	F. Boiler Commissioning	38
D. Component Description	5	G. Commissioning 1000 - 3000	39
II. Product Ratings	7	H. Commissioning 3500 - 6000 High Turndown	40
III. Pre-Installation	8	I. Finish Commissioning the 1000 - 6000	41
A. Installation Conformance	8	J. Re-Starting After Prolonged Shutdown	41
B. Boiler Foundation	8	K. Testing Controls and Safety Devices	42
C. Clearance and Serviceability	8	L. Ignition Failure	42
D. Ambient Boiler Room Temperatures	8	IX. Service, Maintenance, and Inspection	43
IV. Installation	10	A. General Maintenance	43
A. Receiving the Boiler	10	B. Daily	43
B. Boiler Water and Condensate Connections	10	C. Weekly	44
C. Condensate Trap/Drain Assembly	11	D. Monthly	44
D. Gas Supply Connections	11	E. Annually	44
V. Venting	13	F. Ignition Assembly Cleaning	44
A. General Venting Guidelines	13	G. Burner Assembly Cleaning	45
C. Field Installation	14	H. Heat Exchanger Cleaning	45
B. Venting Design Requirements	14	I. Tube Replacement Procedure	45
D. General Termination	19	J. Safety and Operating Controls	49
E. Vent and Combustion Air Terminations	23	K. Troubleshooting	50
F. Multiple Appliance Terminations	25	Appendix A: Sizing Gas Piping	52
G. Terminal Installation	25	Appendix B: Air Switch Adjustment 1500-6000	54
H. Polypropylene Venting	27	Appendix C: Venting Diagrams	55
I. Optional Room Air for Combustion	27	Appendix D: Combustion Air Diagrams	56
J. Removing Existing Appliance	30	Appendix E: Boiler Piping Diagrams	57
K. Special Installation Requirements for Massachusetts	30	Appendix F: Water Flow Pressure Drops	60
VI. Requirements	32	Appendix G: Wiring Diagrams	61
A. Electrical	32	Appendix H: Default Modulation and Lightoff Rates	73
B. Gas Supply Requirements	32	Appendix I: Factory (seller) Limited Warranty	74
C. Sound Pressure Levels	33	Appendix J: Start-up Form	75
D. Pump and Piping Requirements	33		
VII. Before Operation	35		
A. Pre-Boil Out Flushing of System	35		
B. Boiler Out Procedure	35		
C. Replacement Boiler Installations	36		
D. Draining and refilling the boiler & system	36		
E. Boiler Water Quality and Treatment	37		
VIII. System Start-Up	38		
A. Concert Boiler Control Display Navigation	38		
B. System Check	38		
C. Power the Boiler	38		

Table of Figures

I. Introduction	5	Figure 25: Single Boiler, Primary / Secondary	57
Figure 2: 1500-3000 External Boiler Connections	6	Figure 26: Multiple Boilers, Primary Reverse-Return Piping	57
Figure 1: 1000 External Boiler Connections	6	Figure 27: Multiple Boilers, Primary / Secondary Reverse Return Piping	58
Figure 3: 3500-6000 External Boiler Connections	7	Figure 28: Multiple Boilers, Primary / Secondary Piping	58
II. Product Ratings	7	Figure 29: Multiple Boilers, Primary / Secondary With Indirect Water Heater	59
III. Pre-Installation	8	Appendix F: Water Flow Pressure Drops	60
Figure 4: Clearances and Serviceability	9	Appendix G: Wiring Diagrams	61
IV. Installation	10	Figure 30: 1000 Wiring Diagram	61
Figure 6: Condensate Drain Trap	11	Figure 31: 1500 To 3000 115 VAC Single Phase Wiring Diagram	63
Figure 5: Condensate Assembly Orientation	11	Figure 32: 1500 To 3000 208 – 230 VAC Single Phase Wiring Diagram	65
V. Venting	13	Figure 33: 2000 To 3000 208-460 VAC Three Phase Wiring Diagram	67
Figure 7: Vent Terminal Clearances	20	Figure 34: 3500 To 6000 208-460 VAC Three Phase Wiring Diagram	69
Figure 8: Horizontal Sidewall Termination	24	Appendix H: Default Modulation and Lightoff Rates	73
Figure 10: Flat Roof Vent Terminations	24	Appendix I: Factory (seller) Limited Warranty	74
Figure 9: Slopped Roof Termination	24	Appendix J: Start-up Form	75
Figure 11: Multiple Appliance Direct Vent Termination	26		
Figure 12: Flexible Vent in Masonry Chimney with Separate Combustion Air Intake	29		
VI. Requirements	32		
VII. Before Operation	35		
VIII. System Start-Up	38		
Figure 13: 1000-3000 Gas Valve	40		
Figure 14: 3500-6000 Gas Valves	41		
IX. Service, Maintenance, and Inspection	43		
Figure 15: 1000-3000 Ignition Assembly	44		
Figure 16: 3500-6000 Ignition Assembly	44		
Figure 17: Panel Removal in Preparation for Tube Inspection - 1000	46		
Figure 18: Panel Removal in Preparation for Tube Inspection - 1500 - 3000	46		
Figure 19: Panel Removal in Preparation for Tube Inspection, 3000 - 6000	47		
Figure 20: Tube Puller Insertion	48		
Appendix A: Sizing Gas Piping	52		
Appendix B: Air Switch Adjustment 1500-6000	54		
Appendix C: Venting Diagrams	55		
Figure 21: Typical Horizontal Vent Piping	55		
Figure 22: Typical Vertical Pressurized Venting	55		
Appendix D: Combustion Air Diagrams	56		
Figure 23: Typical Horizontal Air Intake Piping	56		
Figure 24: Typical Vertical Air Intake Piping	56		
Appendix E: Boiler Piping Diagrams	57		

Table of Tables

I. Introduction	5	Table 26: Safety Device Tests	42
Table 1: Water Flow Switch Settings	6	IX. Service, Maintenance, and Inspection	43
II. Product Ratings	7	Table 27: Safety and Operating Controls	50
Table 2: Performance Ratings	7	Table 28: General Troubleshooting	51
III. Pre-Installation	8	Appendix A: Sizing Gas Piping	52
Table 3: Clearances to Combustibles and for Serviceability	9	Table 29: Maximum Gas Capacity Of Schedule 40 Pipe	52
IV. Installation	10	Table 30: Equivalent Lengths Of Standard Pipe Fittings And Valves	53
Table 4: Typical Condensate Flow Rate	11	Table 31: Specific Gravity Correction Factors	53
V. Venting	13	Appendix B: Air Switch Adjustment 1500-6000	54
Table 7: Vent and Combustion Air Equivalent Length Calculation Worksheet	15	Appendix C: Venting Diagrams	55
Table 6: Vent and Combustion Air Pipe Diameters and Maximum Lengths	15	Appendix D: Combustion Air Diagrams	56
Table 5: Combustion Air and Flue Gas Requirements	15	Appendix E: Boiler Piping Diagrams	57
Table 8: Vent Air Pressure Drop Data	16	Table 32: Required Common Piping Sizes for Multiple Appliances	59
Table 9: Combustion Air Pressure Drop Data	17	Appendix F: Water Flow Pressure Drops	60
Table 13: Vent and Intake Terminations	18	Appendix G: Wiring Diagrams	61
Table 11: Stainless Steel Vent Adapters	18	Appendix H: Default Modulation and Lightoff Rates	73
Table 10: Approved Vent Manufacturers and Materials	18	Appendix I: Factory (seller) Limited Warranty	74
Table 12: Polypropylene Vent Adapters	18	Appendix J: Start-up Form	75
Table 14: Recommended Venting Configurations and Material Options	19		
Table 15: Other than Direct Vent Terminal Clearances	21		
Table 16: Table of Acceptable Terminations	22		
VI. Requirements	32		
Table 17: Electrical Requirements	32		
Table 18: Gas Supply Requirements	32		
Table 19: Sound Pressure Levels	33		
Table 20: Water Flow Requirements for Variable Primary Piping	34		
Table 21: Water Flow Rates for Primary/Secondary Piping	34		
Table 22: Water Flow Rates for Constant Volume Primary Pumping	35		
Table 23: GPM Increase for Glycol System	35		
VII. Before Operation	35		
Table 24: Water Quality Requirements	37		
Table 25: Chemical Agents and Effects	37		
VIII. System Start-Up	38		

I. Introduction

A. Important Information

The following terms are used throughout this manual to bring attention to the presence of hazards of various risk levels, or to important information concerning product life.

It is critical all personnel read and adhere to all information contained in DANGER, WARNING, and CAUTIONS. All DANGERS, WARNINGS, and CAUTIONS are for reference and guidance purpose, and, therefore, do not substitute for strict adherence to applicable jurisdictional and professional codes and regulations.

⚠ DANGER

Indicates a hazardous situation that, if not avoided, will result in death or serious injury.

⚠ WARNING

Indicates a hazardous situation that, if not avoided, could result in death or serious injury.

⚠ CAUTION

Indicates a hazardous situation that, if not avoided, could result in minor or moderate injury.

NOTICE:

Indicates special instructions on installation, operation, or maintenance which are important but not related to personal injury hazards.

B. Disclaimers and Local Codes

Installation must conform to the requirements of the authority having jurisdiction. In the absence of such requirements, installation must conform to the National Fuel Gas Code, NFPA 54/ANSI Z223.1, and/ or CAN/CGA B149 Installation Codes. Where required by the authority having jurisdiction, the installation must conform to the Standard for Controls and Safety Devices for Automatically Fired Boilers, ANSI/ ASME CSD-1.

Installation, start-up, and maintenance of this equipment can be hazardous and requires trained, qualified installers and service personnel. Do not install, operate, service or repair any components of this equipment unless you are qualified and fully understand all requirements and procedures. Trained personnel refer to those who have completed factory Service School training specific to this product.

The boiler heat exchanger is manufactured and stamped in accordance with ASME Boiler and Pressure Vessel Code, Section IV for a maximum allowable working pressure and operating temperature of 160 psig (1103 kPa) and 210 F(99 C) respectively. Aqua-stat is factory set at 200 F (93 C).

NOTICE:

Post these instructions and maintain in legible condition.

C. Test and Inspections

Upon the completion of boiler installation, final air-fuel adjustments are to be made by factory trained service personnel. The emissions data and the O₂ levels at minimum and maximum input rate can be found on the back side of the front-boiler's door, which can be referenced in the future by the boiler operator(s) when troubleshooting and servicing the boiler. In addition, the following tests and inspections are made on each boiler at the factory to ensure it meets our highest safety and functionality standards.

- ASME hydrostatic test inspection
- Electrical components inspection
- Operating & efficiency test
- Final engineering inspection
- Crating inspection

⚠ DANGER

DO NOT store or use gasoline or other flammable vapors or liquids in the vicinity of this or any other appliance.

If you smell gas vapors, DO NOT try to operate any appliance—DO NOT touch any electrical switch or use any phone in the building. Immediately, call the gas supplier from a remotely located phone. Follow the gas supplier's instructions or if the supplier is unavailable, contact the fire department.

D. Component Description

(See Figure 1, Figure 2 and Figure 3)

1. Touchscreen display. The display provides easy access for viewing and adjusting boiler operational parameters, monitoring historical performance characteristics and annunciating boiler alarm/lockout conditions.
2. Boiler On/Off switch.
3. Manual gas shutoff valve. The boiler is equipped with two manual gas shut off valves, one located on the incoming gas supply line outside of the boiler, and the other downstream of the main gas valve.
4. Main gas supply connection.

5. Pressure relief valve. The pressure relief protects the heat exchanger from an over-pressure condition.
6. Ducted combustion air flange.
7. Flue gas vent outlet. The boiler comes with a standard AL 29-4C® stainless steel vent connection.
8. Boiler water flow switch. The boiler water flow switch is adjustable within the parameters listed in Table 1. (*Located inside the boiler on 1500 - 6000 models*)

Table 1: Water Flow Switch Settings

Settings	Mode Of Operation	
	Switch Closed	Switch Open
Minimum	18	13
Maximum	50	45

9. Return water connection. A 3" diameter Victaulic grooved connection is provided on the 1000. A 3", 150# class, flange is provided on the 1500 – 3000. A 6", 150# class, flange is provided on the 3500-6000.
10. Clean out and inspection. The 1000 has a 3" diameter Victaulic grooved connection is provided for inspecting and cleaning sediment from the heat exchanger. The 1500-6000 has a 1" NPT pipe for blow down to clean sediment from the heat exchanger and a 3" removable plug for inspecting.
11. Supply water connection. A 3" diameter Victaulic grooved connection is provided on the 1000. A 3", 150# class, flange is provide on the 1500 – 3000. A 6", 150# class, flange is provided on the 3500-6000.
12. Air vent. The boiler is provided with an internal dip tube that traps liberated air from the boiler water. The air vent allows the trapped air to escape from the boiler.

References 13 to 15 are not used on the 1000

13. Boiler reset push button
14. Boiler water temperature gauge.
15. Boiler water pressure gauge.

References 16 to 18 are only used on 3500 – 6000

16. Boiler Hand/Off/Auto
17. Push Button Display. The display provides easy access for viewing and adjusting boiler operational parameters and provides alarm/lockout codes.
18. Temperature Display. Provides for temperature set points and actual temperature.

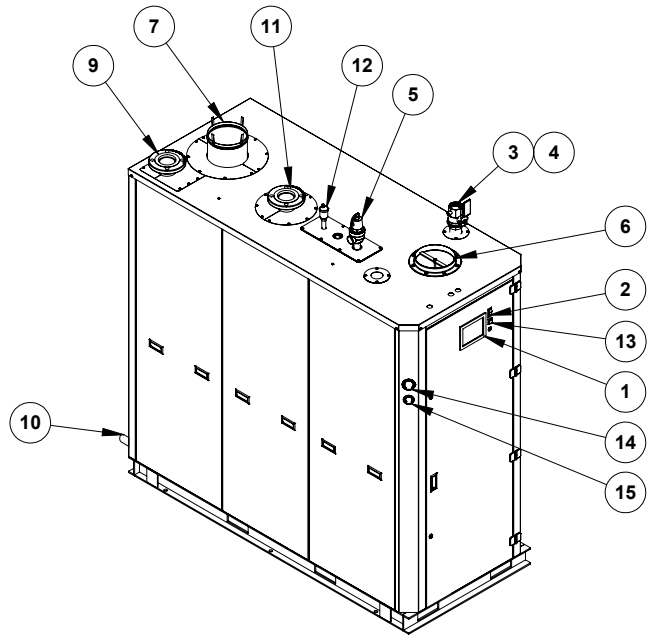

Figure 2: 1500-3000 External Boiler Connections

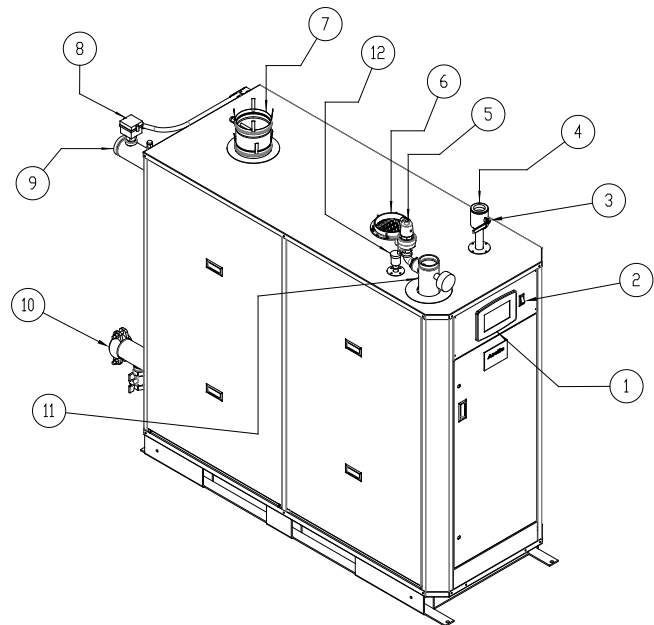

Figure 1: 1000 External Boiler Connections

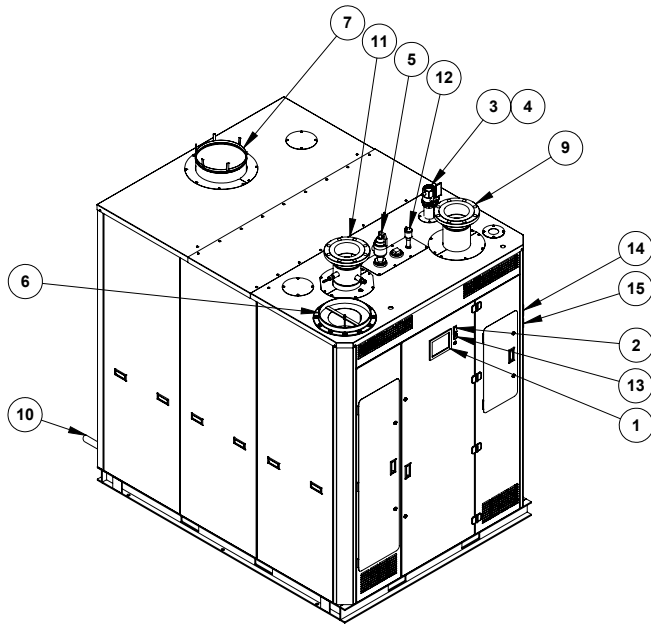



Figure 3: 3500-6000 External Boiler Connections

II. Product Ratings

Table 2: Performance Ratings

Commercial Gas Boiler							
							
Boiler Model	Input (MBH)		Gross Output (MBH)	Net Ratings Water ¹ (MBH)	Thermal Efficiency (%)	Combustion Efficiency (%)	Water Volume (gal)
	Min.	Max.					
1000	200	999	949	825	95	94	19.7
1500	300	1500	1425	1239	95	94	27.3
2000	400	1999	1899	1651	95	94	27.3
2500	500	2500	2375	2065	95	94	39.3
3000	600	3000	2820	2452	95	94	39.3
3500	175	3500	3290	2861	95	94	56.1
4000	200	3999	3759	3269	95	94	56.1
4500	225	4500	4230	3678	95	94	80.9
5000	250	4999	4699	4086	95	94	80.9
5500	275	5500	5170	4496	95	94	80.9
6000	300	6000	5640	4904	95	94	80.9

¹ Ratings shown are for installations at sea level and elevations up to 2000 ft. at minimum vent length. For high altitude installations above 2000 ft. consult factory.

NOTICE:

This boiler is for use with natural gas only.

III. Pre-Installation

The customer should examine the equipment for any damage. It is the responsibility of the installer to ensure all parts supplied with the equipment are fitted in a correct and safe manner.

⚠ WARNING

This boiler requires regular maintenance and service to operate safely. Follow the instructions contained in this manual.

⚠ WARNING

Improper installation, adjustment, alteration, service, or maintenance can cause property damage, personal injury or loss of life. Read and understand the entire manual before attempting installation, start-up operation, or service. Only an experienced, skilled installer or service agency must perform installation and service.

⚠ WARNING

This boiler must be properly vented.
This boiler needs fresh air for safe operation and must be installed so there are provisions for adequate combustion and ventilation air.

A. Installation Conformance

Installation must conform to the requirements of the authority having jurisdiction. In the absence of such requirements, installation must conform to the National Fuel Gas Code, NFPA 54/ANSI Z223.1, and/ or CAN/CGA B149 Installation Codes. Where required by the authority having jurisdiction, the installation must conform to the Standard for Controls and Safety Devices for Automatically Fired Boilers, ANSI/ ASME CSD-1.

B. Boiler Foundation

Before uncrating, the boiler location should be prepared. The boiler should set upon a good level concrete floor. If the boiler is not level or the floor is not in good condition, a concrete foundation should be built, the dimensions being larger than the outside dimensions of the boiler base. A 4" high housekeeping pad is suggested.

⚠ WARNING

Do not install boiler on combustible flooring.

C. Clearance and Serviceability

See Figure 4 and Table 3 for minimum clearances to walls, ceilings, or obstructions. These clearances are intended as a general recommendation only. Local codes must be applied to specific installations and the minimum clearances established accordingly. Provisions must also be made for service, accessibility and clearance for piping and electrical connections. Do not obstruct combustion air and ventilation openings with piping or any other construction. All boilers must be installed in a space that is large compared to the boiler.

D. Ambient Boiler Room Temperatures

This appliance must be installed indoors where the ambient temperature stays within the range of 30 °F to 100°F (-1 to 38°C). When ambient temperatures above 100°F (38°C) are expected, an insulation kit is required. At no point should the ambient temperature be above 115°F.

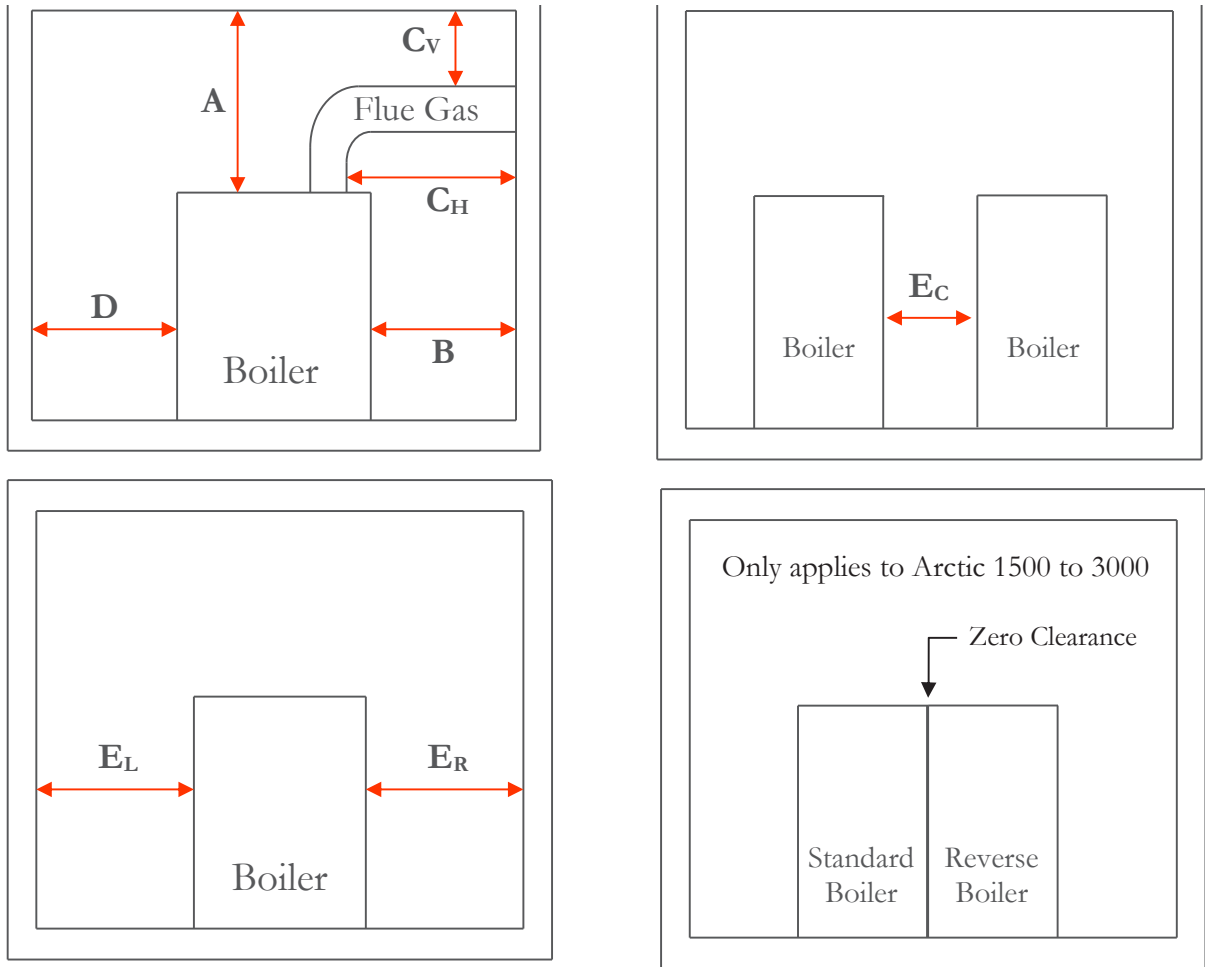

Figure 4: Clearances and Serviceability

Table 3: Clearances to Combustibles and for Serviceability				
Dim	Description	1000	1500-3000	3500-6000
A	Clearance above top of Boiler	6"	6"	6"
B	Front of Boiler - Burner End	24"	32"	43"
C _H	From Chimney or Vent Collector measured horizontally	18"	18"	18"
C _V	From Chimney or Vent Collector measured vertically	18"	18"	18"
D	Rear of Boiler - Opposite Burner End	6"	6"	6"
* E _L	Left Side - Tube access side on standard construction	16"	23"	23"
* E _R	Right Side - Tube access side on standard construction for 3500 - 6000	6"	6"	23"
E _C	Between Boilers	16"	23"	23"

** For Reverse Construction of the 1500 - 3000, the EL and the ER values are swapped*

IV. Installation

A. Receiving the Boiler

The boiler is shipped from the factory with (4) shipping feet/legs bolted to the skids. These are provided to facilitate unloading/moving with a forklift. Lifting points are also provided to enable over-head lifting with spreader bars to prevent damage to the boiler. The shipping feet/legs **MUST BE REMOVED** after the boiler is set in-place on its concrete foundation before any piping/electrical connections are made. It is recommended that the plastic protective cover be left on as long as possible to reduce finish damage from the installation.

B. Boiler Water and Condensate Connections

Do not run any pipes along the tube access panel side of the boiler. Maintain clearances as shown on the dimensional drawing for servicing of the boiler tubes. (See *Figure 4 and Table 3*). All piping should be designed and installed to avoid any loadings on the boiler connections or piping.

1. Flow Connection

- a. The system supply and return flow connections are shown on Figure 1. A gate valve should be installed on the boiler outlet and inlet lines. This allows the boiler to be isolated from the heating system for draining and servicing.

2. Safety Relief Valve

- a. Safety relief valve(s) are shipped loose. Connections are provided in the top of the boiler for the safety relief valve(s). The safety relief valve discharge piping must be the same size as the safety relief valve discharge opening and run to a point of safe discharge. No shutoff valves are to be placed between the relief valve and the appliance or in the discharge piping. Avoid over-tightening as this can distort valve seats. All piping from the safety relief valve(s) must be independently supported with no weight carried by the valve.

NOTICE:

If the relief valve discharges periodically, this may be due to thermal expansion in a closed water supply system. Contact the water supplier or local plumbing inspector on how to correct this situation. **DO NOT PLUG THIS RELIEF VALVE.**

- b. The minimum relief valve setting for standard systems shall be 30 psig. The system shall operate with no less than 26 psig at all times.

- c. For systems designed to operate at delta T's greater than 40°F, the boiler shall be equipped with a minimum relief valve setting of 60 psig. The system shall operate with no less than 50 psig at all times. This will prevent boiler water hammer.

3. Expansion Tank Connections

- a. Connection(s) to an expansion tank are to be provided by others in the system piping separate from the boiler.

4. Drain Connections

- a. A drain valve must be installed on the boiler drain connection, the same pipe size as this connection, to allow draining of the boiler.

5. Condensate Drain Connection

- a. A condensate drain trap is shipped with the boiler and is provided with a 1" npt connection to drain the condensed products of combustion from the boiler. Use Pipe with continuous Teflon, high temperature silicone tubing, or other tubing material compatible with flue gas condensate. The condensate temperature should never exceed 212° F and the pH of the condensate should never have a value lower than 3.5. **NO VALVE** is to be installed in this line from the boiler to point of discharge.
- b. The condensate drain trap should be flushed with water as part of your boiler maintenance schedule to remove any debris that might have accumulated over time. A common condensate pump/sump may be used. Run separate piping from each condensate drain to the sump. A common drain may be used to discharge condensate from the sump. Consult pump/sump materials of construction. If a common sump is used, individual drain lines should be connected such that one drain cannot back feed into another drain. Use Table 4 for sizing the pump / sump.
- c. Consult local authorities regarding disposal of flue gas condensate into public waste water system. Some jurisdictions require that condensate be buffered before discharge. This buffering is commonly achieved by draining the condensate through a limestone bed. Consult factory or a chemical treatment company for buffering system.

Table 4: Typical Condensate Flow Rate

Model	Max Condensate Flow (gph)
1000	11.2
1500	16.8
2000	22.4
2500	27.9
3000	33.5
3500	39.1
4000	44.7
4500	50.3
5000	55.8
5500	61.4
6000	67

⚠ CAUTION

Failure to properly pipe the condensate system will greatly reduce boiler life. Do not install plugs, caps, or valves on condensate piping.

Do not manifold boiler condensate and vent drains together.

Do not crimp condensate lines or reduce drain line inner diameter size.

C. Condensate Trap/Drain Assembly

1. The condensate trap/drain assembly, must be installed to the outlet in the rear of the boiler.
 - a. Mount as shown in Figure 6 and Figure 5 (*Outlet of the vent is to be level*).
 - b. Insert wires through grommet on back panel and plug in the two wires into the bullet plugs inside the back of the boiler.
2. Purpose
 - a. The flue gas trap prevents flue gases from escaping into the boiler room.
 - b. The float switch interrupts the limit string in the event the drainage of the condensate is blocked.

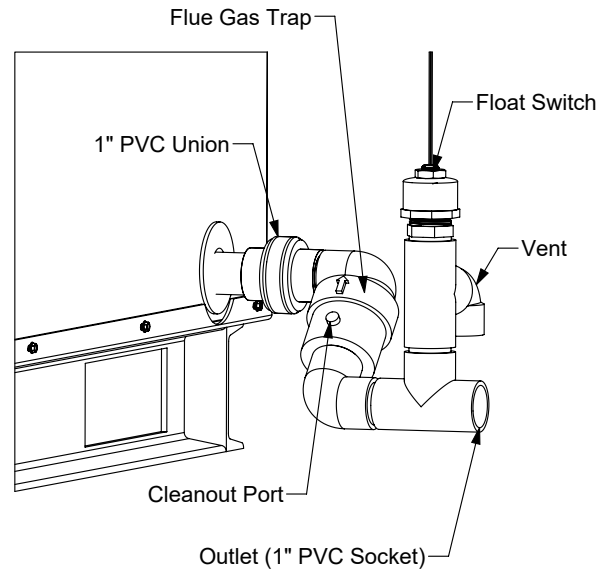

Figure 6: Condensate Drain Trap

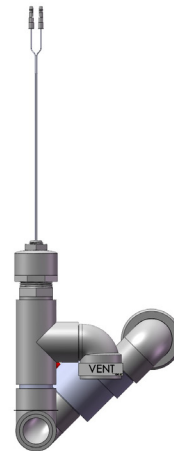

Figure 5: Condensate Assembly Orientation

D. Gas Supply Connections

The installation must conform completely to the requirements of the authority having jurisdiction, or in the absence of such, requirements shall conform in the U.S. to the current National Fuel Gas Code, ANSI Z223.1-1984, or in Canada to the current Natural gas and propane installation code (CAN/CSA B149.1-05), and applicable regional regulations for the class; which should be followed carefully in all cases. Authorities having jurisdiction should be consulted before installations are made. Refer to paragraph 3.5.2 for gas supply requirements.

1. Drip Leg

- a. A drip leg, or sediment trap, is supplied with the gas train. The gas line must be connected to a supply main at least as large as the gas train connection at the boiler. This connection should be made with a union so that the boiler gas train components and burner may be easily removed for service.

2. Gas Piping Leak Test

- a. After completion of the gas-piping hookup, the installation must be checked for leaks. Leaks shall be checked using a soap and water solution. All joints up to the main motorized gas valve shall be checked. A pressure gauge shall be installed down stream of the main motorized gas valve and up stream of the manual gas shutoff valve in the closed position to ensure the main motorized valves are not leaking by. During commissioning, the remainder of the gas train joints down stream of the main motorized gas valve shall be tested for leaks.

3. Venting of Gas Train Components

- a. The MBC (*gas valve*) has an internal, factory installed vent limiter re ANSI Z21.18/ CSA 6.3. Venting required unless otherwise accepted by the authority having jurisdiction.
- b. The high and low gas pressure switches incorporate a vent limiter as per UL 353 and limits the escape of gas less than 1.0 CFH of natural gas at 7 PSI if internal switch diaphragm ruptures.

⚠ WARNING

Combustion air provided solely from an indoor source is discouraged. No dimension for a round or rectangular opening shall be less than 3".

V. Venting

A. General Venting Guidelines

In order to properly vent this boiler, the installer must select and install a venting system that meets all requirements specified in this section, as well as following the instructions provided by the venting system manufacturer:

1. Install vent system in accordance with *National Fuel Gas Code, ANSI Z223.1/NFPA 54* or *Natural Gas and Propane Installation Code, CAN/CSA B149.1 Installation Code for Canada*, or, applicable provisions of local building codes.
2. If this boiler is being installed in Massachusetts, follow the Massachusetts Code Instructions printed near the end of this section in Step K.
3. This boiler, listed as category II or IV, requires special venting system as described in this section.
4. Venting manufacturers not listed in this manual may be acceptable. It is the responsibility of the installer or vent supplier to use compatible adapters and materials.
 - a. It is recommended to consult with venting professionals and designers when determining the vent system for this appliance.
 - b. This boiler is shipped with a Heat-Fab Saf-T-Vent exhaust connection.
 - c. Alteration of the boiler vent connection is prohibited.
5. Recommended flue system materials are listed in Table 10. Other materials may be used that meet the following requirements:
 - a. Flue system material shall be capable of continuous operation at 230°F or higher.
 - b. Flue system and material shall be certified to UL1738 - Venting Systems For Gas-Burning Appliances Categories II, III, and IV.
6. Do not reduce the diameter of the vent pipe. The vent pipe must not be smaller than the vent connector on the boiler.
7. Enclose vent passing through occupied or unoccupied spaces above the appliance with material having a fire resistance rating at least equal to the rating of adjoining floor or ceiling.

⚠ WARNING

This appliance must not be installed in a room under negative pressure. These direct vent gas fired appliances are allowed a maximum leakage of 2% from the venting/combustion chamber and 8% from the air inlet portion when pressurized to operating conditions in a neutral pressure room. An equipment room under negative pressure could deplete the combustion air supply to the appliance and cause leakage of flue gas from the venting system.

Exhaust fans installed in equipment rooms can create negative pressure conditions strong enough to cause nuisance shutdowns of the appliance.

Failure to install the appliance in accordance with this manual can cause property damage, personal injury, or loss of life.

NOTICE

Common venting with other manufacturers' appliances or different product lines is prohibited.

It is the Responsibility of the installing contractor or venting designers to comply with national and local codes and follow best industry practices for installing vent support, drainage, and pitch.

Do not exceed maximum vent/combustion air system length.

8. For flue gas venting, have horizontal runs sloping upwards not less than ¼ inch per foot (21 mm/m) from the boiler to the vent terminal.
9. This appliance operates under conditions that permit condensation in the heat exchanger and the flue gas venting. This appliance shall be installed so as to prevent accumulation of condensate, and where necessary, have means provided for drainage of condensate.
10. If possible, slope horizontal combustion air pipe minimum 1/4 in/ft (21 mm/m) downward towards terminal. If not, slope towards the appliance.
11. It is recommended that a Carbon Monoxide detector be installed and interlocked to the appliance. Consult your local jurisdiction for additional requirements.

B. Venting Design Requirements

At the discretion of the installing contractor, the venting system can be designed by consulting with approved venting engineers or by using the equivalent length method in this manual.

1. Engineered Venting Method

(Recommended Method) Using the operating characteristics and required conditions, an individual or common venting system can be designed to ensure the reliability of the appliance(s).

- a. Flue gas temperatures and flow rates can be found in Table 5.
 - b. The pressure at the flue outlet of the appliance at any given firing rate must be within the range of negative 0.25" W.C. to positive 0.5" W.C.
 - c. The pressure at the intake of the appliance at any given firing rate must be within the range of 0.0" WC to positive 0.1" WC.
 - d. Manifolder venting without backflow prevention can allow flue gas from one appliance to interact with the other appliances in the system. Common venting systems must be designed with backflow protection.
2. **Equivalent length method:** Do not exceed maximum vent/combustion air lengths listed in Table 8. Equivalent lengths of fittings are given in Table 9.

C. Field Installation

1. A factory installed cast aluminum or steel ring provides a means for air intake connection.
2. A factory installed vent connector provides a means for connection to stainless steel venting.
3. Vent and combustion air intake pipe must be supported at intervals no less than (5) feet apart. The completed vent system must be rigid and able to withstand impacts without collapse, to allow uniform flow of combustion air and flue gas.
4. Plan venting system to avoid possible contact with plumbing or electrical wires. Start at the vent connector and work towards the vent termination.
5. Design the air intake system to allow 3/8" (9.5mm) of thermal expansion per 10 ft. (3m) of CPVC/PVC pipe. Runs of 20 ft. (6.1m) or longer that are restrained at both ends must have an offset.
 - a. PVC combustion air pipe joints must be cleaned with primer and glued with cement. Follow all manufacturer instructions and drawings when preparing pipe ends for joining and using the primer and the cement.
6. Size and cut wall opening such that a minimal clearance is obtained and to allow easy insertion of vent pipe.

▲ WARNING

Failure to follow these instructions could cause products of combustion to enter the building, resulting in severe property damage, personal injury, or death.

The use of cellular core PVC (ASTM F891), cellular core CPVC or Radel (polyphenolsulfone) is prohibited.

All condensate that forms in the vent must be able to drain back to the heat exchanger.

Model	Flue gas flow, ACFM @40% XSA 200° F	Combustion air SCFM @40% XSA 0° F	Flue Size
1000	301	220	6"
1500	452	330	8"
2000	603	441	8"
2500	753	550	10"
3000	904	661	10"
3500	1055	771	12"
4000	1206	881	12"
4500	1357	991	14"
5000	1507	1101	14"
5500	1658	1212	14"
6000	1809	1322	14"

Model	Combustion Air Length		Vent Length		Total Combustion air plus vent
	Pipe Dia. In (mm)	Minimum Ft. (m)	Pipe Dia. In (mm)	Minimum Ft. (m)	Maximum ft. (m)
1000	6 (160)	0	6 (160)	3 (0.9)	100 (45.7)
	8 (200)	0	8 (200)	3 (0.9)	100 (45.7)
1500	6 (160)	0	6 (160)	3 (0.9)	100 (45.7)
	8 (200)	0	8 (200)	3 (0.9)	100 (45.7)
2000	8 (200)	0	8 (200)	3 (0.9)	100 (45.7)
2500	10 (250)	0	10 (250)	3 (0.9)	100 (45.7)
3000	10 (250)	0	10 (250)	3 (0.9)	100 (45.7)
3500	12 (315)	0	12 (315)	3 (0.9)	100 (45.7)
4000	12 (315)	0	12 (315)	3 (0.9)	100 (45.7)
4500	14 (356)	0	14 (356)	3 (0.9)	100 (45.7)
5000	14 (356)	0	14 (356)	3 (0.9)	100 (45.7)
5500	14 (356)	0	14 (356)	3 (0.9)	100 (45.7)
6000	14 (356)	0	14 (356)	3 (0.9)	100 (45.7)

Note:
Contact factory for assistance on maximum vent length applications.
This table applies to all listed vent/combustion air system options.

Component	Combustion Air					Vent				
	Equivalent Length Per Piece	X	Quantity	=	Subtotal Equivalent Length	Equivalent Length Per Piece	X	Quantity	=	Subtotal Equivalent Length
Straight Pipe		X		=	A				=	D
90° Elbow		X		=	B				=	E
45° Elbow		X		=	C				=	F
	<i>Combustion Air Total Equivalent Length</i>			=		<i>Vent Total Equivalent Length</i>			=	

Notes:
1. The total combustion air length plus the total vent length cannot exceed the maximum of 100 equivalent feet (30.48 Meters).
2. Combustion air and vent terminations do not count towards total equivalent length.

Table 8: Vent Air Pressure Drop Data

Flue Vent Diameter in. (mm)	Straight Length Equivalent ft/ft (m/m)	90° Elbow (long sweep) Equivalent ft/ft (m/m)	45° Elbow Equivalent ft/ft (m/m)	Velocity (fpm)
<i>1000 Pressure Drop in Equivalent Feet (Meters)</i>				
6 (160)	1 (0.304)	10 (3.04)	5 (1.524)	1534
8 (200)	0.22 (0.07)	2.22 (0.676)	1.11 (0.338)	863
<i>1500 Pressure Drop in Equivalent Feet (Meters)</i>				
8 (200)	0.56 (0.17)	5.88 (1.792)	2.86 (0.871)	1296
10 (250)	0.174 (0.053)	1.75 (0.533)	0.87 (0.265)	829
<i>2000 Pressure Drop in Equivalent Feet (Meters)</i>				
8 (200)	1 (0.304)	10 (3.048)	5 (1.524)	1728
10 (250)	0.31 (0.09)	3.125 (0.952)	1.56 (0.475)	1106
12 (315)	0.12 (0.036)	1.19 (0.362)	0.59 (0.179)	768
<i>2500 Pressure Drop in Equivalent Feet (Meters)</i>				
8 (200)	1.56 (0.047)	16.67 (5.081)	8.33 (2.538)	2158
10 (250)	0.478 (0.145)	5 (1.524)	2.44 (0.743)	1381
12 (315)	0.183 (0.055)	1.852 (0.564)	0.92 (0.28)	959
<i>3000 Pressure Drop in Equivalent Feet (Meters)</i>				
8 (200)	2.22 (0.068)	25 (7.62)	11.11 (3.386)	2591
10 (250)	0.68 (0.207)	7.14 (2.176)	3.57 (1.088)	1658
12 (315)	0.267 (0.081)	2.7 (0.822)	1.35 (0.411)	1152
<i>3500 Pressure Drop in Equivalent Feet (Meters)</i>				
10 (250)	0.455 (0.138)	4.55 (1.386)	2.727 (0.831)	1935
12 (315)	0.172 (0.052)	1.724 (0.525)	0.862 (0.252)	1344
14 (356)	0.08 (0.024)	0.77 (0.234)	3.85 (1.173)	987
<i>4000 Pressure Drop in Equivalent Feet (Meters)</i>				
10 (250)	0.95 (0.289)	10 (3.048)	4.76 (4.76)	2212
12 (315)	0.37 (0.112)	3.7 (1.127)	1.85 (0.563)	1536
14 (356)	0.16 (0.048)	1.64 (0.499)	0.81 (0.248)	1129
<i>4500 Pressure Drop in Equivalent Feet (Meters)</i>				
12 (315)	0.47 (0.143)	4.76 (1.45)	2.33 (0.71)	1729
14 (356)	0.21 (0.064)	2.08 (0.633)	1.03 (0.313)	1270
16 (406)	0.1 (0.03)	1.02 (0.31)	0.51 (0.155)	972
<i>5000 Pressure Drop in Equivalent Feet (Meters)</i>				
12 (315)	0.57 (0.173)	5.71 (1.74)	2.85 (0.868)	1920
14 (356)	0.25 (0.076)	2.56 (0.78)	1.27 (0.387)	1410
16 (406)	0.13 (0.039)	1.27 (0.387)	0.63 (0.192)	1080
<i>5500 Pressure Drop in Equivalent Feet (Meters)</i>				
12 (315)	0.69 (0.21)	6.9 (2.103)	3.45 (1.051)	2112
14 (356)	0.31 (0.094)	3.13 (0.954)	1.54 (0.469)	1552
16 (406)	0.15 (0.045)	1.52 (0.463)	0.76 (0.231)	1188
<i>6000 Pressure Drop in Equivalent Feet (Meters)</i>				
12 (315)	0.83 (0.252)	8.33 (2.538)	4.17 (1.271)	2304
14 (356)	0.36 (0.109)	3.7 (1.127)	1.85 (0.563)	1693
16 (406)	0.19 (0.057)	1.82 (0.554)	0.91 (0.277)	1296

Table 9: Combustion Air Pressure Drop Data

Flue Vent Diameter in. (mm)	Straight Length Equivalent ft/ft (m/m)	90° Elbow (long sweep) Equivalent ft/ft (m/m)	45° Elbow Equivalent ft/ft (m/m)	Velocity (fpm)
<i>1000 Pressure Drop in Equivalent Feet (Meters)</i>				
6 (160)	0.6 (0.182)	6.25 (1.905)	3.13 (0.954)	1121
8 (200)	0.13 (0.039)	1.32 (0.402)	0.658 (0.2)	631
<i>1500 Pressure Drop in Equivalent Feet (Meters)</i>				
8 (200)	0.3 (0.091)	3.03 (0.923)	1.49 (0.045)	946
10 (250)	0.09 (0.027)	0.92 (0.28)	0.46 (0.14)	605
<i>2000 Pressure Drop in Equivalent Feet (Meters)</i>				
8 (200)	0.53 (0.161)	5.26 (1.603)	2.63 (0.801)	1264
10 (250)	0.164 (0.049)	1.64 (0.499)	0.82 (0.249)	809
12 (315)	0.063 (0.019)	0.63 (0.192)	0.314 (0.095)	562
<i>2500 Pressure Drop in Equivalent Feet (Meters)</i>				
8 (200)	0.83 (0.250)	8.3 (2.529)	4.17 (1.271)	1576
10 (250)	0.26 (0.079)	2.56 (0.78)	1.28 (0.39)	1009
12 (315)	0.1 (0.03)	0.98 (0.298)	0.49 (0.149)	701
<i>3000 Pressure Drop in Equivalent Feet (Meters)</i>				
8 (200)	1.19 (0.362)	12.5 (3.81)	5.9 (1.798)	1895
10 (250)	0.37 (0.112)	3.7 (1.127)	1.85 (0.563)	1213
12 (315)	0.14 (0.042)	1.41 (0.429)	0.7 (0.213)	842
<i>3500 Pressure Drop in Equivalent Feet (Meters)</i>				
10 (250)	0.39 (0.118)	3.92 (1.194)	1.96 (0.597)	1414
12 (315)	0.15 (0.045)	1.49 (0.454)	0.75 (0.228)	982
14 (356)	0.07 (0.021)	0.67 (0.204)	0.33 (0.1)	722
<i>4000 Pressure Drop in Equivalent Feet (Meters)</i>				
10 (250)	0.51 (0.155)	5.13 (1.563)	2.56 (0.78)	1616
12 (315)	0.2 (0.06)	1.96 (0.597)	0.97 (0.295)	1122
14 (356)	0.087 (0.026)	0.87 (0.265)	0.44 (0.134)	825
<i>4500 Pressure Drop in Equivalent Feet (Meters)</i>				
12 (315)	0.25 (0.076)	2.5 (0.762)	1.23 (0.374)	1264
14 (356)	0.11 (0.033)	1.1 (0.335)	0.55 (0.167)	928
16 (406)	0.054 (0.016)	0.55 (0.167)	0.27 (0.082)	711
<i>5000 Pressure Drop in Equivalent Feet (Meters)</i>				
12 (315)	0.31 (0.094)	3.13 (0.954)	1.54 (0.469)	1403
14 (356)	0.14 (0.042)	1.35 (0.411)	0.68 (0.207)	1030
16 (406)	0.067 (0.02)	0.67 (0.204)	0.34 (0.103)	789
<i>5500 Pressure Drop in Equivalent Feet (Meters)</i>				
12 (315)	0.37 (0.112)	3.7 (1.127)	1.85 (0.563)	1544
14 (356)	0.17 (0.051)	1.64 (0.499)	0.82 (0.249)	1134
16 (406)	0.082 (0.024)	0.81 (0.246)	0.41 (0.124)	868
<i>6000 Pressure Drop in Equivalent Feet (Meters)</i>				
12 (315)	0.44 (0.134)	4.55 (1.386)	2.22 (0.676)	1684
14 (356)	0.2 (0.06)	1.96 (0.597)	0.98 (0.298)	1237
16 (406)	0.097 (0.295)	0.97 (0.295)	0.49 (0.149)	947

<i>Brand</i>	<i>Material</i>	<i>Model</i>
Heat Fab	Stainless Steel	Saf-T Vent EZ Seal*
Z-Flex (Nova Flex Group)	Stainless Steel / Polypropylene	Z-Vent/Z-DENS
DuraVent	Stainless Steel / Polypropylene	FasNSeal/ PolyPro Single Wall Rigid
Centrotherm	Polypropylene	InnoFlue SW Rigid
Jeremias	Stainless Steel	SWGv

*Factory supplied flue connection. Adapters are required to transition to alternate vent materials or manufacturers.

Vent Diameter (in.)	Heat Fab to Z-Vent	Factory to SWGV
	<i>Z-Flex Part #</i>	<i>Jeremias part #</i>
8	2SVSHF08	SWGv8-RCIS
10	2SVSHF10	SWGv10-RCIS
12	2SVSHF12	SWGv12-RCIS
14	2SVSHF14	SWGv14-RCIS

Model	Vent Dia. (in.)	Centrotherm part # (Innoflue PP System)	Z-Flex Part # (Z-DENS PP Systems)
1000-2000	8	ISSA0808	2ZDAHf8
2500-3000	10	ISSA1010	---
3500-4000	12	ISSA1212	---
4500-6000	14	Not Available	

Model	Vent Dia. (in.)	Style	Stainless Steel		Polypropylene	
			Heat Fab Part # (Saf-T Vent)	Z-Flex Part # (Z-Vent)	Centrotherm Part # (InnoFlue)	Z-Flex Part # (Z-DENS)
1000-2000	8	Tee	9890TEE	2SVST08	ISTT0820	2ZDTT6
		Elbow	9814TERM	2SVEE0890	---	---
		Straight	9892	2SVSTPX08	ISEP086	---
2500-3000	10	Tee	91090TEE	2SVST10	ISTT1020	2ZDTT8
		Elbow	91014TERM	2SVEE1090	---	---
		Straight	91092	2SVSTPX10	ISEP106	---
3500-4000	12	Tee	91290TEE	2SVST12	ISTT1220	---
		Elbow	91214TERM	2SVEE1290	---	---
		Straight	91292	2SVSTPX12	ISEP126	---
4500-6000	14	Tee	N/A	2SVST14	Not Available	
		Elbow	N/A	2SVEE1490		
		Straight	91492	2SVSTPX14		

Table 14: Recommended Venting Configurations and Material Options						
Vent & Intake Materials	Vent Options	Type	Penetration Through Structure	Termination	Parts Table	Reference Figure
Two Pipe Stainless Steel vent, Galvanized Steel or PVC intake	1	Intake	Horizontal Sidewall	Tee or Elbow	Table 13	Figure 8
		Vent	Horizontal Sidewall	Tee or Straight		---
	2	Intake	Horizontal Sidewall	Tee or Elbow		---
		Vent	Vertical Roof	Tee or Straight		Figure 9 Figure 10
	3	Intake	Vertical Roof	Tee or 2 Elbows		---
		Vent	Vertical Roof	Tee or Straight		Figure 9 Figure 10
Two Pipe Polypropylene vent, Galvanized Steel or PVC intake	4	Intake	Horizontal Sidewall	Tee	Table 13	Figure 8
		Vent	Horizontal Sidewall	Tee or Straight		---
	5	Intake	Horizontal Sidewall	Tee		---
		Vent	Vertical Roof	Tee or Straight		Figure 9 Figure 10
	6	Intake	Vertical Roof	Tee or 2 Elbows		---
		Vent	Vertical Roof	Tee or Straight		Figure 9 Figure 10
Room air for combustion; SS or PP vent	10	Vent	Horizontal Sidewall	Tee or Straight	Table 13	---
	11	Vent	Vertical Roof	Tee or Straight		---
Notes: 1. It is recommended to use tees for both intake and vertical terminations in extra windy locations. 2. All terminations shall have bird screens. 3. All non-metallic venting exposed to sunlight shall be UV resistant.						

D. General Termination

1. Use only listed vent/combustion air terminals.
2. Follow the termination configurations shown in Table 14, and see Table 16 for acceptable termination components.
3. Maintain correct clearance and orientation between vent and combustion air terminals.
 - a. The required spacing between vent and combustion air terminals is to prevent flue gas recirculation. Recirculation of flue gas products into the combustion air supply can cause damage to property or the appliance.
 - b. When installed on the same wall, locate vent terminal 4 vent pipe diameters above the combustion air terminal. The snorkel configuration can be used when penetrations are at the same height.
4. Locate bottom of vent and combustion air terminals at least 12 in. (300 mm) [18 in. (460 mm) in Canada] above the normal snow line and at least 12 in. (300 mm) above grade level.
5. Do not install vent terminal directly above windows or doors.
6. Locate bottom of vent terminal at least 3 ft. (900 mm) above any forced air inlet located within 10 ft. (3.0 m).
7. If window and/or air inlet is within 4 ft. (1.2 m) of an inside corner, maintain at least 6 ft. (1.8 m) spacing between terminal and adjoining wall of inside corner.
8. Locate bottom of vent terminal at least 7 ft. (2.1 m) above a public walkway.
9. Maintain minimum clearance of at least 4 ft. (1.2 m) [3 ft. (900 mm) in Canada] horizontally between vent terminal and gas meters, electric meters, regulators, and relief equipment. Do not install vent terminal above or below this equipment.
10. Do not locate the vent terminal under decks or similar structures.
11. Top of terminal must be at least 24 in. (600 mm) below ventilated eaves, soffits, and other overhangs. In no case may the overhang exceed 48 in. (1200 mm). Where permitted by the authority having jurisdiction and local experience, the terminal may be located closer to unventilated soffits. The minimum vertical separation depends upon the depth of the soffit.
12. For multiple appliance installations with vertical roof terminals, separate vent pipes may be piped through a common conduit or chase so that one roof penetration may be made. Maintain recommended separations of terminations after penetration.

13. Maintain minimum 24 in. (610 mm) horizontal spacing between vent terminal and a building corner.
14. Under certain conditions, water in the flue gas may condense, and possibly freeze, on objects around the terminal including on the structure itself. If these objects are subject to damage by flue gas condensate, they should be moved or protected.
15. If possible, install the vent and combustion air terminals on a wall away from the prevailing wind. Reliable operation of this product cannot be guaranteed if terminals are subjected to winds in excess of 40 mph (64 km/hr).
16. Do not locate combustion air terminal in areas that might contain combustion air contaminants, such as near swimming pools.

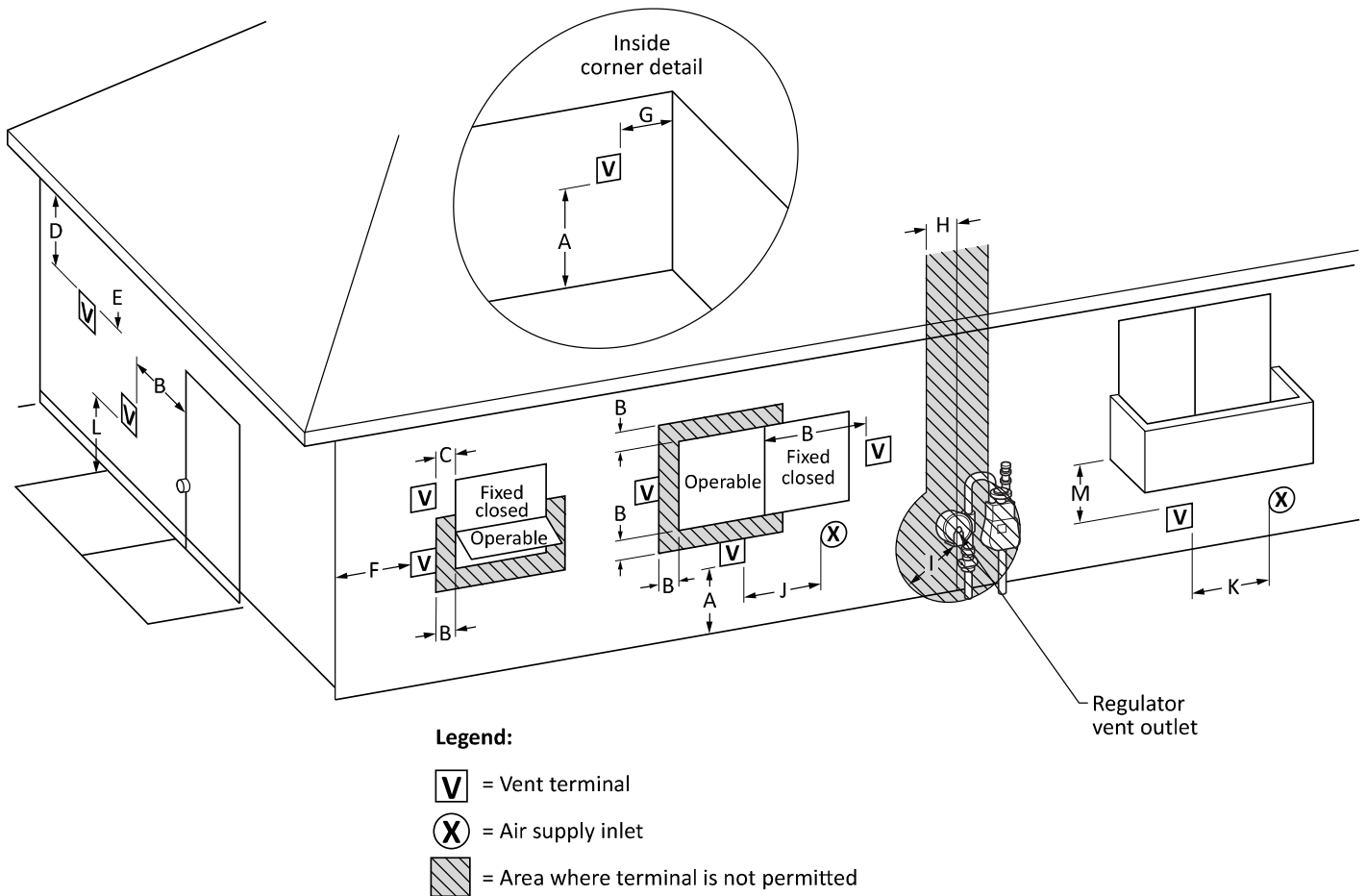

Figure 7: Vent Terminal Clearances

Table 15: Other than Direct Vent Terminal Clearances

		Canadian Installations ¹	US Installations ²
A	Clearance above grade, veranda, porch, deck, or balcony	18 in (46 cm)	12 in (30 cm)
B	Clearance to window or door that may be opened	6 in (15 cm) for appliances ≤ 10,000 Btuh (3 kW), 12 in (30 cm) for appliances > 10,000 Btuh (3 kW) and ≤ 100,000 Btuh (30 kW), 36 in (91 cm) for appliances >100,000 Btuh (30 kW)	4 ft (1.2 m) below or to side of opening; 1 ft (300 mm) above opening
C	Clearance to permanently closed window	*	*
D	Vertical clearance to ventilated soffit located above the terminal within a horizontal distance of 2 ft (61 cm) from the center line of the terminal.	*	*
E	Clearance to unventilated soffit	*	*
F	Clearance to outside corner	*	*
G	Clearance to inside corner	*	*
H	Clearance to each side of center line extended above meter/regulator assembly	3 ft (91 cm) within a height 15 ft (4.6 m)	*
I	Clearance to service regulator vent outlet	3 ft (91 cm)	*
J	Clearance to nonmechanical air supply inlet to building or the combustion air inlet to any other appliance	6 in (15 cm) for appliances ≤ 10,000 Btuh (3 kW), 12 in (30 cm) for appliances > 10,000 Btuh (3 kW) and ≤ 100,000 Btuh (30 kW), 36 in (91 cm) for appliances >100,000 Btuh (30 kW)	4 ft (1.2 m) below or to side of opening; 1 ft (300 mm) above opening
K	Clearance to a mechanical air supply inlet	6 ft (1.83 m)	3 ft (91 cm) above if within 10 ft (3 m) horizontally
L	Clearance above paved sidewalk or paved driveway located on public property	7 ft (2.13 m) †	7 ft (2.13 m) for mechanical draft systems (Category I appliances). Vents for Category II and IV appliances cannot be located above public walkways or other areas where condensate or vapor can cause a nuisance or hazard
M	Clearance under veranda, porch deck, or balcony	12 in (30 cm) ‡	*
<p>* Clearance in accordance with local codes and the requirements of the gas supplier. † A vent shall not terminate directly above a sidewalk or paved driveway that is located between two single family dwellings and serves both dwellings. ‡ Permitted only if veranda, porch, deck, or balcony is fully open on a minimum of two sides beneath the floor. Notes: 1) In accordance with the current CSA B149.1, Natural Gas and Propane Installation Code 2) In accordance with the current ANSI Z223.1/NFPA 54, National Fuel Gas Code 3) If locally adopted installation codes specify clearances different than those illustrated, then the most stringent clearance shall prevail.</p>			

Table 16: Table of Acceptable Terminations

Flue Gas Vent Terminations

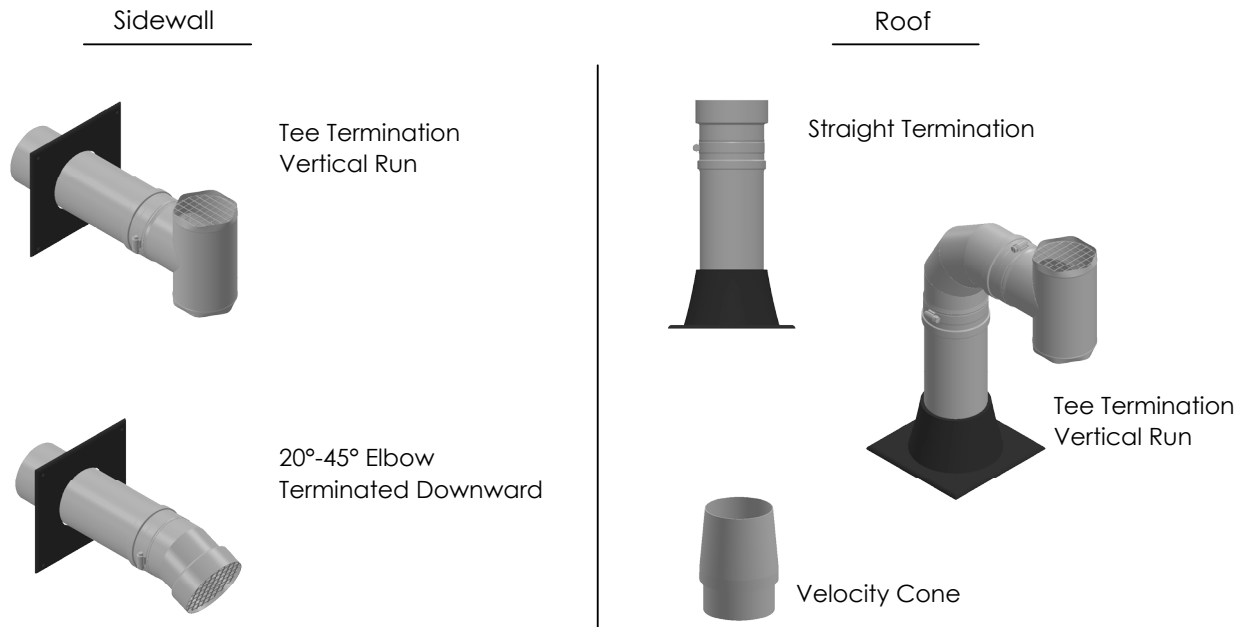

Combustion Air Intake Terminations

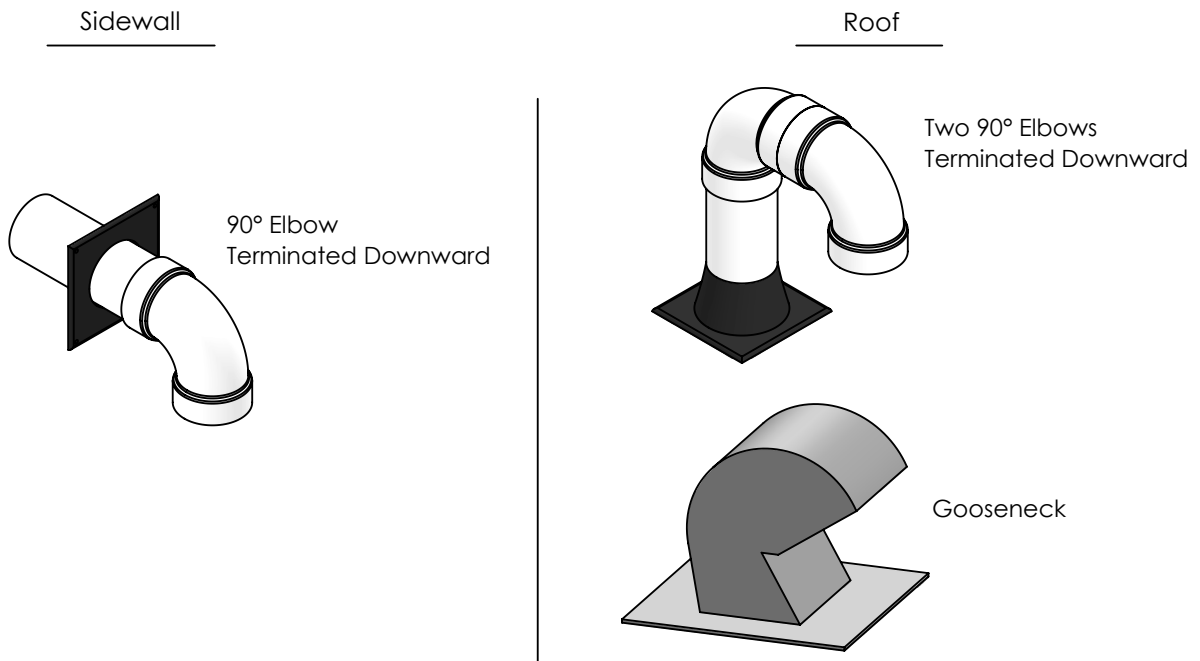

Notes:
 Do not use Louvers for direct vent systems
 One appliance per gooseneck termination
 Vent and intake piping must not share the same gooseneck
 All terminations should have Bird/Rodent Screens
 Do not use rain caps, Rain will drain through boot tee or condensate drain

E. Vent and Combustion Air Terminations

1. Vent Piping

- a. Install fire stops where vent passes through floors, ceilings or framed walls. The fire stop must close the opening between the vent pipe and the structure.
- b. Whenever possible, install vent straight through the roof.
- c. Size roof opening to maintain minimum clearance of 1 in. (25 mm) from combustible materials.
- d. Extend vent pipe to maintain minimum vertical distance for expected snow accumulation. Provide brace as required.
- e. Install storm collar on vent pipe immediately above flashing. Apply Dow Corning Silastic 732 RTV Sealant or equivalent between vent pipe and storm collar to provide weather-tight seal.

2. Combustion Air Piping

- a. If possible, locate combustion air termination in the same roof location as the vent termination to prevent nuisance shutdowns. Alternatively, this appliance may be installed with a vertical roof vent terminal and sidewall combustion air terminal.
- b. Size roof opening to allow easy insertion of combustion air piping and allow proper installation of flashing and storm collar to prevent moisture from entering the structure.
- c. Use appropriately designed vent flashing when passing through roofs. Follow flashing manufacturers' instructions for installation.
- d. Extend combustion air pipe to maintain minimum vertical and horizontal distance of 12 in (300 mm) from roof surface or from the maximum snow level.

⚠ CAUTION

Reliable operation of this appliance is not guaranteed when the terminals are subject to winds above 40 mph. The required spacing between vent and combustion air terminals is to prevent flue gas recirculation. Recirculation of flue gas products into the combustion air supply can cause damage to property or the appliance.

⚠ WARNING

Failure to vent this appliance in accordance with these instructions could cause products of combustion to enter the building resulting in severe property damage, personal injury or death.

Do not locate vent termination under a deck, or where exposed to prevailing winds.

Do not locate combustion air termination where volatile vapors or other chemicals are present. Severe corrosion and failure will result.

Do not interchange vent systems or materials unless otherwise specified.

Do not apply thermal insulation to vent pipe or fittings.

Do not use a barometric damper or draft hood with this appliance.

NOTICE:

Methods of securing and sealing terminals to the outside wall must not restrain the thermal expansion of the vent pipe.

Exterior run should be included in equivalent vent/combustion air lengths.

Vertical Venting and combustion air roof penetrations (where applicable) require the use of roof flashing and storm collar, which are not supplied with appliance, to prevent moisture from entering the structure.

Examine all components for possible shipping damage prior to installation.

All condensate that forms in vent must be able to drain back to the heat exchanger or a boot tee with a drain.

The venting system must be free to expand and contract and must be supported in accordance with installation instructions included by the original component manufacturers, whenever applicable. Polypropylene pipe sections must be disengaged 1/4 to 5/8 in. (6 mm to 16 mm) per joint to allow for thermal expansion.

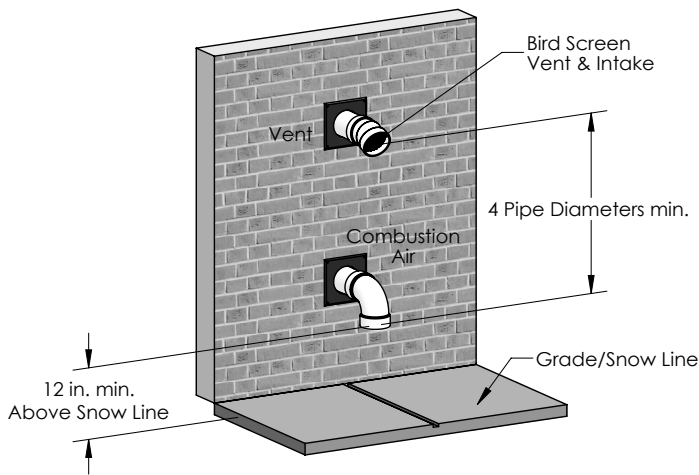

Figure 8: Horizontal Sidewall Termination

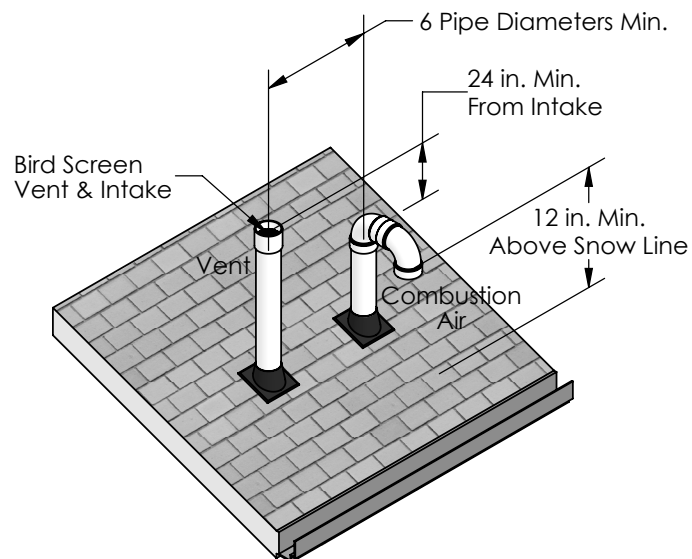

Figure 9: Sloped Roof Termination

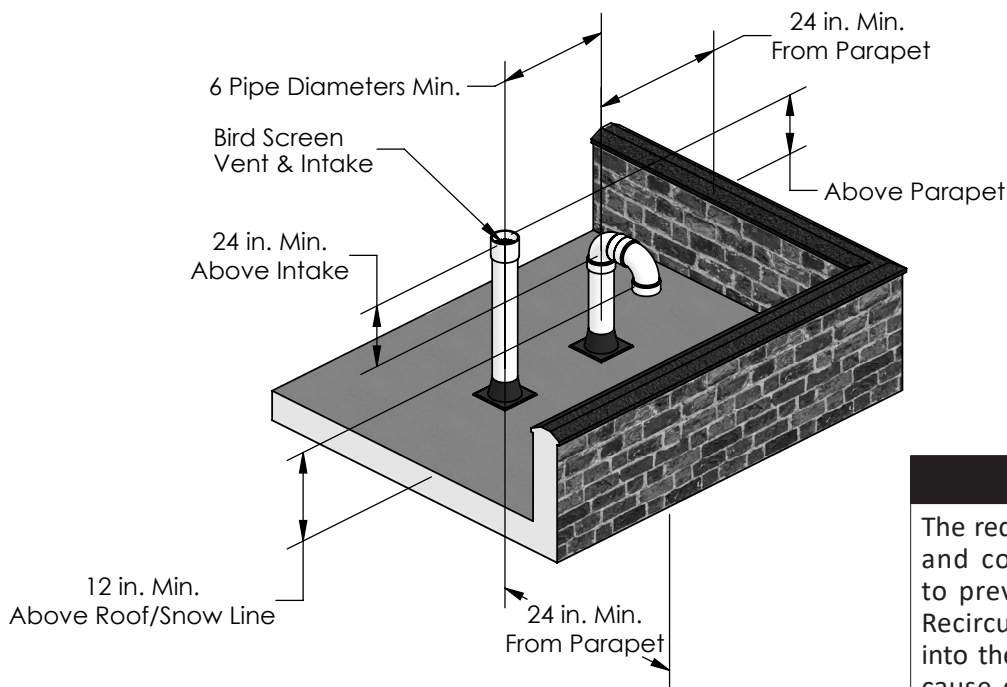

Figure 10: Flat Roof Vent Terminations

⚠ CAUTION

The required spacing between vent and combustion air terminals is to prevent flue gas recirculation. Recirculation of flue gas products into the combustion air supply can cause damage to property or the appliance.

Notes:

1. All terminations must have bird/rodent screens.
2. If Possible, Install Sidewall venting on a wall away from prevailing wind.
3. For roof terminations, install vent terminal downstream of prevailing winds relative to intake terminal.
4. It is recommended to use tee terminations with a vertical run in extra windy areas.

⚠ CAUTION

The required spacing between vent and combustion air terminals is to prevent flue gas recirculation. Recirculation of flue gas products into the combustion air supply can cause damage to property or the appliance.

F. Multiple Appliance Terminations

1. Vent Piping Terminations
 - a. Multiple appliance vent terminations are shown in Figure 11.
 - b. Each individual appliance must have its own vent pipe and vent terminal unless a common venting system is used following the guidelines of the "Engineered Venting Method" section in this manual.
 - c. For horizontal sidewall terminations, maintain at least 6 pipe diameters minimum horizontal distance between any adjacent individual vent terminations. Additional horizontal spacing between any adjacent individual vent terminations as well as extending the distance from building surfaces to vent termination end are recommended to avoid frost damage to building surfaces where vent terminations are placed.
 - d. Multiple individual vertical vent pipes may be piped through a common conduit or chase so that one roof penetration may be made.
 - e. For vertical roof terminations, maintain at least 6 pipe diameters minimum horizontal distance between adjacent individual appliance vent terminations.
2. Combustion Air Piping
 - a. Multiple appliance combustion air terminations are shown in Figure 11.
 - b. Each individual appliance must have its own combustion air pipe and terminal when using category IV venting.
 - c. Individual appliance sidewall terminals must be placed at least 12 in. (300 mm) [18 in. (460 mm) in Canada] above the ground plus the expected snow accumulation.
 - d. Do not exceed the maximum combustion air pipe length for an individual appliance as listed in Table 6.
 - e. If possible, locate the vent and combustion air terminals for each appliance on the same wall to prevent nuisance shutdowns. If not, each appliance may be installed with a roof vent terminal and sidewall combustion air terminal.

⚠ CAUTION

The vent for this appliance shall not terminate:

1. Over public walkways; or
2. Near soffit vents or crawl space vents or other areas where condensate or vapor could create a nuisance or hazard or cause property damage; or
3. Where condensate vapor could cause damage or could be detrimental to the operation of regulators, relief valves, or other equipment.

G. Terminal Installation

1. Use the terminal connections supplied by the venting manufacturer. Follow manufacturer's instructions to attach the terminal to the vent system.
2. For PVC/CPVC terminals, apply a heavy bead of silicone to the male end of the terminal before inserting it into the last piece of pipe. Orient the terminal so that the seam in the terminal is at 12:00. Smooth the silicone over the seam between the terminal and the last piece of pipe, applying additional silicone if necessary to ensure a tight seal. Allow the silicone to cure per the silicone manufacturer's instructions before operating the appliance.
3. Install Bird/Rodent screens in the terminals. Use a screen having 1/2 in. x 1/2 in. (13 mm x 13 mm) mesh.
4. Adhere to the minimum and maximum wall thickness specified by the manufacturer of the wall penetration assembly.

NOTICE:

The joint between the terminal and the last piece of pipe must be outside of the building.

⚠ WARNING

Moisture and ice may form on the surface around vent termination.

To prevent deterioration, surface must be in good repair (sealed, painted, etc.).

Do not allow low spots in the vent where condensate may pool.

Use specified vent and combustion air pipe diameters.

All vent and combustion air piping must be sealed and airtight.

Alteration of the appliance vent connection is prohibited.

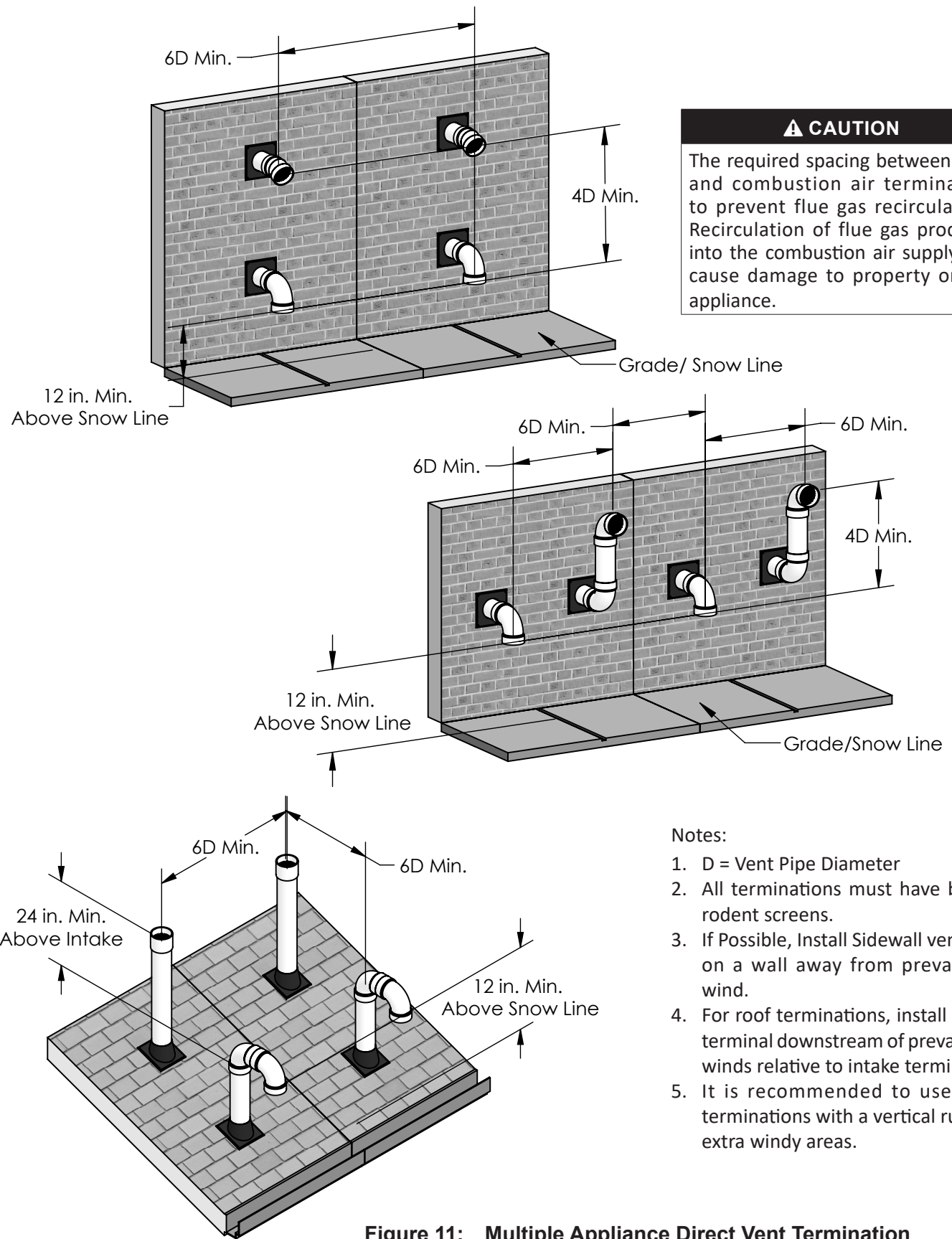

Figure 11: Multiple Appliance Direct Vent Termination

Notes:

1. D = Vent Pipe Diameter
2. All terminations must have bird/rodent screens.
3. If Possible, Install Sidewall venting on a wall away from prevailing wind.
4. For roof terminations, install vent terminal downstream of prevailing winds relative to intake terminal.
5. It is recommended to use tee terminations with a vertical run in extra windy areas.

⚠ CAUTION

Installing multiple vent terminations too close together may result in combustion product water vapor condensation on building surfaces where vent terminations are placed, causing subsequent frost damage. To avoid/minimize frost damage, extend the distance from building surfaces to vent termination end and increase the horizontal distance between adjacent vent terminations.

H. Polypropylene Venting

1. Running Flexible Polypropylene Vent (Liner) Through Unused Chimney Chase
 - a. It is the responsibility of the installing contractor to procure polypropylene vent system pipe and related components.
 - b. All listed polypropylene vent system manufacturers must comply with the requirements of *ULC-S636-08* 'Standard for Type BH Gas Venting Systems'. For Canadian installation, polypropylene vent must be listed as a *ULC-S636* approved system.
 - c. Flexible polypropylene pipe must be treated carefully and stored at temperatures higher than 41 degrees F.
 - d. When flexible polypropylene pipe (liner) is used for combustion air supply, the pipe (liner) can be installed in a vertical or horizontal position.
 - e. Follow manufacturer instructions regarding application/listing, permits, minimum clearances to combustibles, and installation details (proper joint assembly, pipe support and routing, gasket and fitting installation, optional tooling availability/usage, routing through masonry chimney for combustion product venting or, combination of combustion product venting and combustion air supply).
 - f. When using a masonry chimney as a passageway for flexible polypropylene pipe, the chase must be structurally sound and free of any debris or obstructions.
 - g. To prevent condensate pooling and damage to vent, offsets (*bend*) cannot exceed 45°. Multiple offsets are allowed in a chase.
2. Pressure drop for flexible polypropylene line is 20 % greater than from rigid pipe. Multiply measured flexible polypropylene liner length by 1.2 to obtain equivalent length.

⚠ WARNING

Asphyxiation Hazard. Vent systems made by listed PP vent system manufacturers rely on gaskets for proper sealing. When this type of vent system is used, take the following precautions:

Make sure that gasket is in position and undamaged in the female end of the pipe.

Make sure that both male and female pipes are free of damage prior to assembly.

Only cut vent pipe as permitted by the vent manufacturer in accordance with their instructions. When pipe is cut, the cut end must be square and carefully deburred prior to assembly.

Use locking band clamps at all vent pipe joints.

Flexible polypropylene vent must be installed only in an unused chimney. A chimney, either single or multiple flue type, is considered unused when one of the flues is being used for any appliance venting, or When one of the multiple flues is being used for appliance venting. The flexible vent installation is not permitted through any of the adjacent flues.

Do not bend or attempt to install flexible pipe if it has been stored at ambient temperature below 41 F. This will cause material to become brittle and will lead to cracks, resulting in flue gas leaks.

Do not install flexible polypropylene pipe at an angle greater than 45 degrees from vertical when used for combustion product venting. Failure to do so will result in improper condensate drainage and possible subsequent vent pipe blockage.

3. Maximum equivalent vent length of flexible polypropylene liner is 48 ft. (14.6 m).

I. Optional Room Air for Combustion

1. General Guidelines
 - a. Room air is optional for commercial applications. Follow the requirements in this section when air for combustion is supplied from the boiler room.
 - b. Avoid combustion air contaminants in the boiler room. Permanently remove any contaminants found in the boiler room. If contaminants cannot be removed, do not use room air for combustion.
 - c. Natural gas and propane installation code specifies venting systems and air supply for appliances, air supply shall be provided when either an appliance or a combination of appliances has a total input exceeding 400,000 Btuh.
2. Outdoor Openings to Boiler Room

- a. Provide combustion and ventilation air to the boiler room or enclosure. Follow the National fuel Gas Code, *ANSI Z223.1*, or, in Canada, Installation Code for Gas Burning Appliances and Equipment, *CGA Standard B149 Code* as well as all applicable local codes. Use one of the following methods.
- b. Two Permanent Openings Method: Provide two permanent openings, once within 12 in. (300 mm) of the top of the enclosure and one within 12 in. (300 mm) of the bottom of the enclosure. Openings must communicate directly, or by ducts, with the outdoors or spaces that freely communicate with the outdoors, as follows:
 - i. Direct communication or through vertical ducts: minimum free area of each opening shall be 1 in.²/4,000 Btu/hr (550 mm²/kW) of total input rating of all appliances within the enclosure.
 - ii. Horizontal ducts: minimum free area of each opening shall be 1 in.²/2,000 Btu/hr (1,100 mm²/kW) of total input rating of all appliances within the enclosure.
- c. One Permanent Opening Method: Provide one permanent opening, commencing within 12 in. (300 mm) of the top of the enclosure. The opening shall communicate through a vertical or horizontal duct to the outdoors or spaces that freely communicate with the outdoors and shall have a minimum free area of the following:
 - i. 1 in.²/3,000 Btu/hr (700 mm²/kW) of total input rating of all appliances located within the enclosure.
 - ii. Not less than the sum of the areas of all vent connectors in the space.

3. Louvers and Dampers

- a. Openings in a fixed louver, grille, or screen shall have no dimension smaller than 1/4" (6mm).
- b. No manually operated damper or manually operated adjustable louvers are permitted.
- c. Motorized louvers or dampers must be interlocked with the boiler to allow ignition and firing of the burner only when louvers are in the fully-open position.

4. Mechanical Combustion Air Supply

- a. When combustion air is supplied by mechanical means, an airflow sensing device shall be installed and wired into the safety limit circuit of the primary safety control to shut off the gas in the event of air supply failure.

⚠ WARNING

Asphyxiation Hazard. Common manifold venting requires special considerations. Follow the instructions in this manual

Factory takes no responsibility for vent systems that create issues and or affect the performance of the appliance.

Improper Installation of a Category II vent system resulting in positive pressure in the vent system can result in flue gas spillage and carbon monoxide emissions, causing severe personal injury or death.

Sources of combustion air contaminants, including chlorines, chlorofluorocarbons (CFC's), petroleum distillates, detergents, volatile vapors or other chemicals must not be present in the boiler room. If any of these contaminants are present, severe corrosion and failure will result.

NOTICE:

Pressure drop for flexible polypropylene line is 20 % greater than from rigid pipe. Multiply measured flexible polypropylene liner length by 1.2 to obtain equivalent length.

Maximum equivalent vent length of flexible polypropylene liner is 48 ft. (14.6 m).

Installation of a polypropylene vent system should adhere to the vent manufacturer's installation instructions supplied with the vent system.

⚠ WARNING

DO NOT mix vent systems of different types or manufacturers. Failure to comply could result in severe personal injury, death, or substantial property damage.

Do NOT connect venting to a chimney flue that is servicing a separate appliance designed to burn solid fuel.

Do not insulate polypropylene vent pipes. Excessive heat could cause premature vent pipe failure.

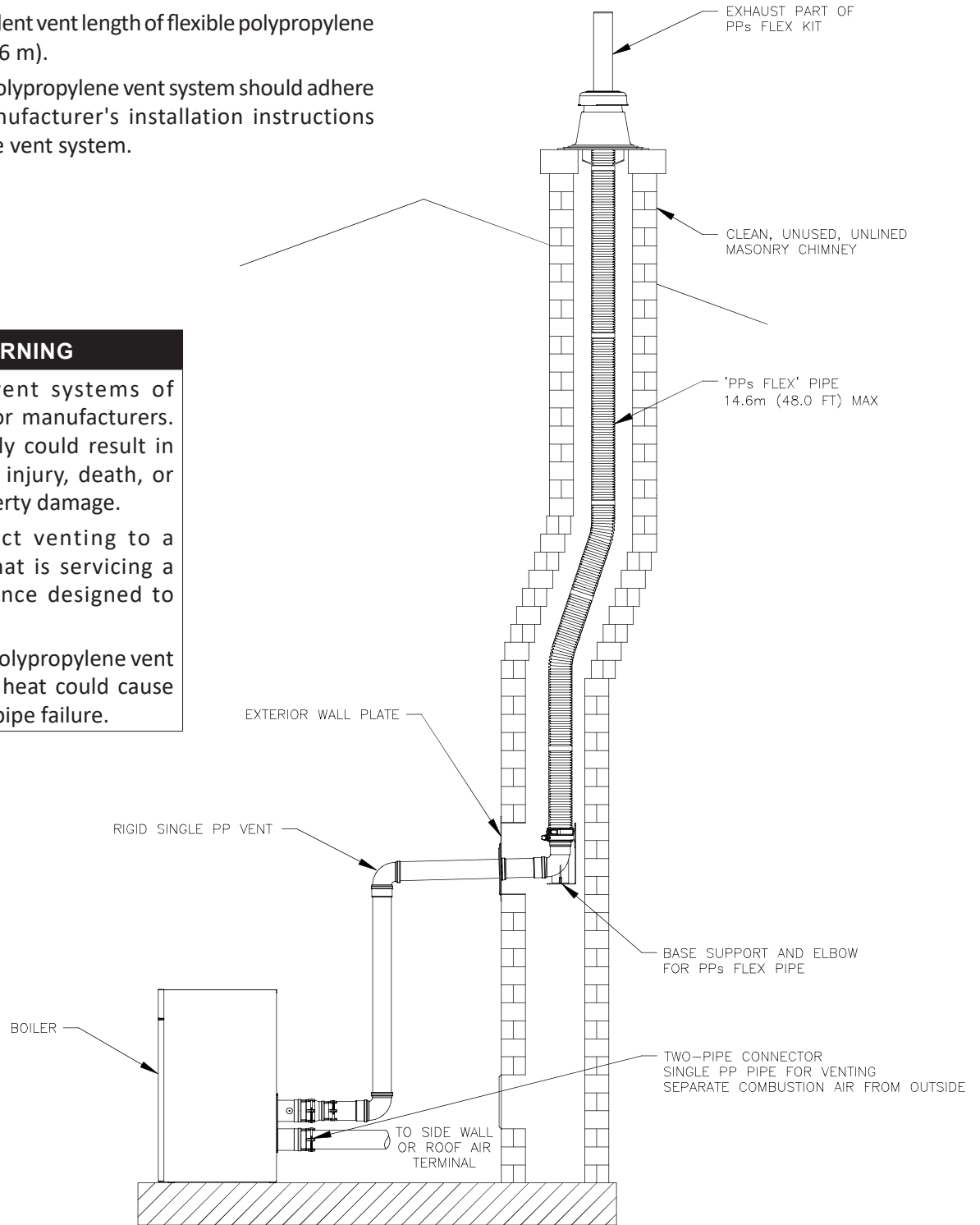

Figure 12: Flexible Vent in Masonry Chimney with Separate Combustion Air Intake

NOTICE:

Please note that the information provided in this manual relative to the Canadian Standard is not meant to be all-inclusive. Reading the entire Standard is strongly suggested. The final approval of all system designs must be acceptable to the authority having jurisdiction.

J. Removing Existing Appliance

When an existing appliance is removed from a common venting system, the common venting system is likely to be too large for proper venting of the remaining appliances. At the time of removal of an existing appliance, the following steps should be performed with each appliance remaining connected to the common venting system. Make sure the appliances are not in operation while carrying out these steps.

1. Seal any unused openings in the common venting system.
2. Visually inspect the venting system for proper size and horizontal pitch and ensure there is no blockage or restriction, leakage, corrosion, or other deficiencies which could cause an unsafe condition.
3. Insofar as is practical, close all exterior doors and windows, and all doors between the space where the appliances connect to the common venting system and other spaces of the building. Turn on any exhaust fans, such as range-hoods and bathroom exhausts, so they will operate at maximum speed. Do not operate a summer exhaust fan. Close fireplace dampers.
4. Place in operation the appliance being inspected. Follow the Lighting (or Operating) Instructions. Adjust thermostat so appliance will operate continuously.
5. Test for spillage at the draft hood relief opening after 5 minutes of main burner operation. Use the flame of a match or candle, or smoke from a cigarette, cigar or pipe.
6. After it has been determined that each appliance connected to the common venting system properly vents when tested as outlined above, return doors, windows, exhaust fans, fireplace dampers and any other gas burning appliance to their previous conditions of use.

7. Any improper operation of the common venting system should be corrected so the installation conforms with the *National Fuel Gas Code, ANSI Z223.1/NFPA 54* and/or the *Natural Gas and Propane Installation Code, CAN/CSA B149.1*. Resizing of any portion of the common venting system, should be done in accordance with the *National Fuel Gas Code, ANSI Z223.1/NFPA 54* and/or the *Natural Gas and Propane Installation Code, CAN/CSA B149.1*.

K. Special Installation Requirements for Massachusetts

1. For all sidewall horizontally vented gas fueled equipment installed in every dwelling, building or structure used in whole or in part for residential purposes and where the sidewall exhaust vent termination is less than seven (7) feet above grade, the following requirements shall be satisfied:
 - a. If there is no carbon monoxide detector with an alarm already installed in compliance with the most current edition of NFPA 720, NFPA 70 and the Massachusetts State Building Code in the residential unit served by the sidewall horizontally vented gas fueled equipment, a battery operated carbon monoxide detector with an alarm shall be installed in compliance with the most current edition of NFPA 720, NFPA 70 and the Massachusetts State Building Code.

- b. In addition to the above requirements, if there is not one already present, a carbon monoxide detector with an alarm and a battery back-up shall be installed and located in accordance with the installation requirements supplied with the detector on the floor level where the gas equipment is installed. The carbon monoxide detector with an alarm shall comply with 527 CMR, ANSI/UL 2034 Standards or CSA 6.19 and the most current edition of NFPA 720. In the event that the requirements of this subdivision can not be met at the time of the completion of the installation of the equipment, the installer shall have a period of thirty (30) days to comply with this requirement; provided, however, that during said thirty (30) day period, a battery operated carbon monoxide detector with an alarm shall be installed in compliance with the most current edition of NFPA 720, NFPA 70 and the Massachusetts State Building Code. In the event that the sidewall horizontally vented gas fueled equipment is installed in a crawl space or an attic, the carbon monoxide detector may be installed on the next adjacent habitable floor level. Such detector may be a battery operated carbon monoxide detector with an alarm and shall be installed in compliance with the most current edition of NFPA 720, NFPA 70 and the Massachusetts State Building Code.
 - c. A metal or plastic identification plate shall be permanently mounted to the exterior of the building at a minimum height of eight (8) feet above grade directly in line with the exhaust vent terminal for the horizontally vented gas fueled heating appliance or equipment. The sign shall read, in print size no less than one-half (1/2) inch in size, "GAS VENT DIRECTLY BELOW. KEEP CLEAR OF ALL OBSTRUCTIONS".
 - d. A final inspection by the state or local gas inspector of the sidewall horizontally vented equipment shall not be performed until proof is provided that the state or local electrical inspector having jurisdiction has granted a permit for installation of carbon monoxide detectors and alarms as required above.
2. EXEMPTIONS: The following equipment is exempt from 248 CMR 5.08(2)(a) 1 through 4:
 - a. The equipment listed in Chapter 10 entitled "Equipment Not Required To Be Vented" in the most current edition of NFPA 54 as adopted by the Board; and
 - b. Product Approved sidewall horizontally vented gas fueled equipment installed in a room or structure separate from the dwelling, building or structure used in whole or in part for residential purposes.
 3. When the manufacturer of Product Approved sidewall horizontally vented gas equipment provides a venting system design or venting system components with the equipment, the instructions for installation of the equipment and the venting system shall include:
 - a. A complete parts list for the venting system design or venting system; and
 - b. Detailed instructions for the installation of the venting system design or the venting system components.
 4. When the manufacturer of a Product Approved sidewall horizontally vented gas fueled equipment does not provide the parts for venting flue gases, but identifies "special venting systems", the following shall be satisfied:
 - a. The referenced "special venting system" instructions shall be included with the appliance or equipment installation instructions; and
 - b. The "special venting systems" shall be Product Approved by the Board, and the instructions for that system shall include a parts list and detailed installation instructions.
 5. A copy of all installation instructions for all Product Approved sidewall horizontally vented gas fueled equipment, all venting instructions, all parts lists for venting instructions, and/or all venting design instructions shall remain with the appliance or equipment at the completion of the installation.

VI. Requirements

A. Electrical

⚠ WARNING

All electrical connections must conform to the National Electrical Code, ANSI / NFPA 70 and / or CSA C22.1 Electrical Code and all other State and Local codes.

A separate electrical circuit must be run from the main electrical service with an over-current device/disconnect in the circuit. A service switch is recommended and may be required by some local jurisdictions. Locate the service switch such that the appliance can be shut off without exposing personnel to danger in the event of an emergency. See Table 17 for available voltages.

Table 17: Electrical Requirements

1000				
<i>Voltage</i>	<i>FLA</i>	<i>CCA</i>	<i>MHP</i>	<i>MA</i>
120/1/60	6.6	2.6	.46	4
1500				
<i>Voltage</i>	<i>FLA</i>	<i>CCA</i>	<i>MHP</i>	<i>MA</i>
120/1/60	13.1	2.6	1.1	10.5
208-240/1/60	6.9	2.6	1.1	4.3
2000 to 3000				
<i>Voltage</i>	<i>FLA</i>	<i>CCA</i>	<i>MHP</i>	<i>MA</i>
120/1/60	15.6	2.6	1.5	13
208-240/1/60	8.3	2.6	1.5	5.7
208-240/3/60	9.5	2.6	3	6.9
480/3/60	5.25	1.25	3.2	4
3500 to 4000				
<i>Voltage</i>	<i>FLA</i>	<i>CCA</i>	<i>MHP</i>	<i>MA</i>
208-240/3/60	10.5	2.6	3	6.9
480/3/60	5.25	1.25	3.2	4
4500 to 6000				
<i>Voltage</i>	<i>FLA</i>	<i>CCA</i>	<i>MHP</i>	<i>MA</i>
208-240/3/60	26.6	2.6	10.7	24
480/3/60	14.25	1.25	10.7	13
FLA = Full Load Amps : CCA = Control Circuit Amps : MHP = Motor Horse Power : MA = Motor Amps				

Connect field supplied safety limits or devices using proper terminals provided in boiler electrical cabinet. Refer to wiring diagram supplied with boiler for wiring information.

See Appendix G for sample-wiring diagrams. An as-built wiring diagram is included with every boiler when it ships. Contact a factory Representative or visit the website for current wiring options.

B. Gas Supply Requirements

Refer to Table 18 for minimum and maximum gas supply pressure. When the gas supply pressure exceeds the maximum, an additional field supplied step down regulator will be required to reduce the supply pressure. For proper gas supply sizing refer to Table 29.

NOTICE:

The step down regulator shall be installed at least 60 pipe diameters from the boiler gas inlet manual shutoff valve and vented to atmosphere. Vent Limiters are NOT acceptable. This will ensure proper gas regulation for establishing main flame reliably.

Table 18: Gas Supply Requirements

Model	Capacity (MBH)	Inlet (npt)	Min. (iwc)	Max. (iwc)
1000	999	1	4	14
1500	1500	2	4	14
2000	1999	2	4	14
2500	2500	2	4	14
3000	3000	2	4	14
3500	3500	2	7	14
4000	3999	2	7	14
4500	4500	2	7	14
5000	4999	2	7	14
5500	5500	2	7	14
6000	6000	2	7	14

C. Sound Pressure Levels

Sound pressure levels were measured at 4-1/2' above the floor and 3' from the boiler at the front, rear and two sides. See Table 19 for decibel readings.

Table 19: Sound Pressure Levels

Model	Decibel Levels			
	<i>Front</i>	<i>Rear</i>	<i>Tube Side</i>	<i>Right Side</i>
1000	68	61	63	64
1500	67	60	61	63
2000	67	60	61	63
2500	62	62	66	61
3000	62	62	66	61

D. Pump and Piping Requirements

Pump piping and system piping must meet the requirements of local codes and jurisdictions. Good engineering practices should be followed and considered for each piping system used.

It is advised that the circulating pump for each boiler be installed as close to the boiler as possible in the line to the return connection such that system water is pumped towards the boiler.

Installing circulating pumps so that the water is pumped away from the boiler is rarely recommended.

Means to eliminate air from the boiler/piping systems is a must. It is advised that an air separator be installed as close as practical to each boiler in the outlet pipe. Further, an air vent should be installed at all high points throughout the piping system.

It is recommended that a water meter be installed in the make-up water system to the boiler system. Scheduled recording of the water meter register will show an indication of a potential slow system leak in addition to providing insight into any system problems. Also, make-up water as well as water for the initial system fill should be provided through a water softener. Additionally, chemical treatment of the system water is advisable. Contact a qualified boiler water chemical treatment company for their recommendations. See Section VII, Step "E. Boiler Water Quality and Treatment" for more information.

See Appendix F for boiler water flow pressure drop data and Appendix E for piping.

1. Water Flow Rates (*Variable Primary Pumping Systems*)

- a. Variable primary pumping systems shall be capable of delivering no less than the minimum and no more than the maximum specified in Table 20 for each boiler connected in the system.

Table 20: Water Flow Requirements for Variable Primary Piping

Model	Maximum MBH		Minimum Flow Rate			Maximum Flow Rate		
	Input	Output	gpm	Δ P (ft)	High Fire Δ T (°F)	gpm	Δ P (ft)	High Fire Δ T (°F)
1000	999	949	19	.51	100	95	12.7	20
1500	1500	1425	29	.37	100	143	9.2	20
2000	1999	1899	38	.65	100	190	16.3	20
2500	2500	2375	48	.8	100	238	20	20
3000	3000	2820	57	1.15	100	285	28.7	20
3500	3500	3290	67	.42	100	333	11.33	20
4000	3999	3759	76	.42	100	380	15.17	20
4500	4500	4230	86	.42	100	428	25.17	20
5000	4999	4699	95	.5	100	475	33.5	20
5500	5500	5170	105	.58	100	523	37.25	20
6000	6000	5640	114	.67	100	570	37.92	20

Note: not for sizing constant volume pump

2. Water Flow Rates (Primary/Secondary Systems)

- a. Each boiler connected to a secondary loop of a primary / secondary pumping system shall have a constant volume pump sized in accordance with Table 21.

Table 21: Water Flow Rates for Primary/Secondary Piping

Model	Maximum MBH		20°F ΔT Flow Rate				40°F ΔT Flow Rate			
	Input	Output	gpm	Δ P (ft)	High Fire Δ T (°F)	Low Fire Δ T (°F)	gpm	Δ P (ft)	High Fire Δ T (°F)	Low Fire Δ T (°F)
1000	999	949	95	12.7	20	4	48	3.18	40	8
1500	1500	1425	143	9.2	20	4	71	2.3	40	8
2000	1999	1899	190	16.3	20	4	95	4.08	40	8
2500	2500	2375	238	20	20	4	119	5	40	8
3000	3000	2820	285	28.7	20	4	143	7.18	40	8
3500	3500	3290	333	11.33	20	4	166	2.67	40	8
4000	3999	3759	380	15.17	20	4	190	3.17	40	8
4500	4500	4230	428	25.17	20	4	214	6.25	40	8
5000	4999	4699	475	33.5	20	4	238	7.92	40	8
5500	5500	5170	523	37.25	20	4	261	9.25	40	8
6000	6000	5640	570	37.92	20	4	285	9.42	40	8

Note: not for sizing constant volume pump

3. Water Flow Rates (*Constant Volume Primary Pumping Systems*)

- a. A constant volume primary pumping system shall be sized so that the flow rate specified in Table 22 can be maintained through each boiler connected to the system.

Table 22: Water Flow Rates for Constant Volume Primary Pumping

Model	Maximum Flow Rate		
	gpm	Δ P (ft)	High Fire Δ T (°F)
1000	95	12.7	20
1500	143	9.2	20
2000	190	16.3	20
2500	238	20	20
3000	285	28.7	20
3500	333	11.33	20
4000	380	15.17	20
4500	428	25.17	20
5000	475	33.5	20
5500	523	37.25	20
6000	570	37.92	20

4. Water Flow Rates for Glycol

- a. For glycol systems the gpm in the flow rate tables will increase as specified in Table 23.

Table 23: GPM Increase for Glycol System

Glycol Concentration	GPM Percent Increase
50%	24%
30%	14%

VII. Before Operation

A. Pre-Boil Out Flushing of System

Much of the dirt and contamination in a new hot water system can be flushed out before the boil out of the system. First, flush the system of waste with clear water. The boiler and circulating pumps must be isolated through the successive zones of the system to waste, carrying metal shavings, dirt, pipe joint compound, etc. with it. Follow with a chemical flush.

⚠ WARNING

Be CERTAIN that the chemicals used to flush and boil-out the boiler and system contain NO CHLORIDES. The boiler is fabricated with austenitic stainless steels that can be severely damaged when exposed to chlorides.

The removal of pipe chips and other debris from the system before opening the isolation valves to the boiler and pumps will help to protect this equipment from damage by such debris.

In combination with system contamination, bacteria from ground water boiler water may produce objectionable odors, sometimes resembling the odorant used in natural gas. It is important to keep these fumes from air intakes that would distribute them throughout the building.

B. Boiler Out Procedure

⚠ WARNING

The boil out procedure outlined must be performed by, or under the direct supervision of, a qualified technician. The chemicals used present a hazard of burns and physical injury if mishandled. Always use a suitable face mask, goggles, protective gloves, and garments when handling caustic chemicals. Do not permit the chemical to come into contact with skin or clothing. Always follow the safety precautions on the container's label. Add chemicals slowly and in small amounts to prevent excessive heat and agitation.

The boil out of the boiler and system is neither difficult nor expensive. The chemicals needed for cleaning are readily available. Tri-sodium phosphate and sodium hydroxide (*lye*) are the most commonly used chemicals. Be certain the chemicals used contain NO CHLORIDES. Use only one type of solution in the system. The amount of chemical required will vary according to conditions, but one pound per fifty gallons of water is suggested.

Fill the system with this solution, venting all air. Then, with the circulating pump running, bring the system to design or operating temperature. After circulating water for two to three hours, the system should be drained completely, and refilled with fresh, softened water. Usually enough of the cleaning solution will adhere to the piping to result in an alkaline solution satisfactory for operation. A pH reading between, 8.3 – 10.5 is preferred. If necessary, to increase the pH, a small amount of cleaner may be added.

C. Replacement Boiler Installations

Clean or replace all system piping and heating units.

Arrange for chemical or mechanical cleaning of the entire system. A chemical treatment company should be consulted for the proper means of any chemical cleaning. Replace any piping that is deteriorated beyond safe or cleanable condition.

Flush the system clean, being certain to isolate the boiler.

⚠ WARNING

Do not flush the system through the boiler.

For some old systems, there is a reluctance to clean the piping because of possible leaks occurring in badly corroded lines. Should the customer refuse cleaning, it is necessary to install filtration equipment. Install either a fibrous filter or a centrifugal filter in the boiler return piping. This will collect and remove sediment from the system. A booster pump may be required to overcome the additional pressure drop introduced in the line by the filter. When filling the system, provide chemical treatment as outlined in section "E. Boiler Water Quality and Treatment".

Failure to properly clean the system or to install mechanical sediment removal equipment can result in tube blockage and severe corrosion plus damage to pumps, controls, and air removal devices.

Inspect, repair as necessary, or replace system air control devices.

Install gauge glasses on air expansion tanks and install a tank fitting in the system connection to the tank.

Install a strainer in the boiler return piping.

D. Draining and refilling the boiler & system

If the system is drained and then refilled, chemical treatment is essential to treat the raw water. Use only clean, softened water.

⚠ WARNING

Use only clean, softened, and treated water. Chemical treatment of the raw water is essential when filling or refilling the system

1. Hydrostatic Test of Boilers and System

- a. After completing the boiler and burner installation, the boiler connections, fittings, attachments and adjacent piping must be inspected for leaks by filling the unit with water. The pressure should be gradually increased to a pressure just below the setting of boiler safety relief valve(s).
- b. Remove the boiler tube access panels (see dimensional drawing in the boiler manual). Inspect the tube to header joints to be certain that all tube fittings are sealed. This is necessary because, although the boiler is hydrostatically tested at the factory, minor leaks in fittings and at attachments can develop from shipping vibration or from installation procedures. Replace tube access panels before proceeding to start boiler

E. Boiler Water Quality and Treatment

1. The water directly in contact with the appliance must meet the requirements in this section. Failure to adhere to the water treatment requirements in this manual can cause damage not covered by warranty to the appliance, pumps, or other components in the system.
2. It will be necessary to gain knowledge of the impurities dissolved in the water and consult with a qualified industrial water treatment professional to establish a treatment plan. In addition, a periodic testing/sampling plan should be developed.
3. To minimize corrosion and scale effects, adhere to the water quality requirements in Table 24.
 - a. If the water hardness is higher than 160 ppm (9 gpg), a water softener must be used.
4. Total Dissolved Solids (TDS) contribute to scale buildup. If the TDS or combined water hardness and TDS exceeds 450 ppm, the water needs to be heated indirectly.

Table 24: Water Quality Requirements

Quality Parameter	Min.	Max.
Water Hardness* (gpg)	0	9
Chloride (ppm)	-	200
pH (cold)	6.5	9.5
pH (systems with aluminum)	6.5	8.5
Notes: The combined water hardness and TDS cannot exceed 450 ppm. 1 grain per gallon = 17.1 ppm		

5. Continuous Monitoring
 - a. Water treatment should be checked and maintained according to Table 24 whenever the boiler is operating. The boiler operator should be sure that the boiler is not operating for long periods without proper water treatment.
 - b. Water treatment may vary from season to season or over a period of time. Therefore, the water treatment procedure should be checked not less than four times a year and possibly more frequently as the local water conditions may indicate.

- c. See Table 25 for examples of typical chemical agents found in untreated water along with their potential effects.

Table 25: Chemical Agents and Effects

Compound	Effect
Calcium Carbonate, ($CaCO_3$)	Soft Scale
Calcium Bicarbonate ($CaHCO_3$)	Soft scale, CO_2
Calcium Sulphate ($CaSO_4$)	Hard Scale
Calcium Chloride ($CaCl_2$)	Corrosion
Magnesium Carbonate ($MgCO_3$)	Soft Scale
Magnesium Bicarbonate ($MgHCO_4$)	Corrosion, Scale
Magnesium Sulphate ($MgSO_4$)	Corrosion
Silicon Dioxide (SiO_2)	Hard Scale

- d. It should be noted that water boilers may well need chemical treatment for the first filling plus additional periodic chemical treatment, depending on system water losses and the makeup requirements.
- e. All water introduced into the boiler should be softened and should include an oxygen scavenger like sodium sulfite. This is required to remove dissolved oxygen from the water. Dissolved oxygen will cause severe system corrosion.

⚠ CAUTION

Factory Standard Warranty does not cover problems caused by oxygen contamination of boiler water.
 Factory Standard Warranty does not cover problems caused by scale build-up.
 When using Glycol products, all Glycol manufacturers' requirements, including rust inhibitors, must be adhered.
 Max 50% Glycol.

⚠ WARNING

Chemicals used in treating boiler water are toxic and/or harmful. Always use protective clothing and equipment when working with/near chemicals. Contact local authorities to determine if treated boiler water can be discharged into local waste water system.

VIII. System Start-Up

WARNING

Completely read, understand and follow all instructions in this manual, Concert Boiler Control manual, and all other component manuals supplied with this boiler before attempting start-up.

A. Concert Boiler Control Display Navigation

This boiler is equipped with a color touch screen display, which presents information and control options in a page manner. Pages are arranged in a tree structure through which the user navigates up and down to arrive at the desired function. The page descriptions and a complete list of the available control parameters are provided in a separate instruction manual for the Concert boiler control (*Also supplied with the boiler*).

Most pages have a Home button in the top-left corner of the screen. The Home button returns the user to the Home page to view real time operation of the boiler.

The back button returns the user to the previous page.

A padlock icon will be shown on the screens that require the user to enter a password to change the parameter. An unlocked padlock indicates the correct password has been entered to change the parameter.

The user can access the following icons from the Home screen: Menu, Info, Status, Adjust, and Help. It is important that the user become familiar in accessing additional icons that are not shown on the home screen page.

NOTICE:

Refer to the Concert Boiler Control manual for detailed instructions on the use of the hydronic control and display.

B. System Check

1. Verify that the venting, water piping, gas piping and electrical system are installed properly. Refer to installation instructions contained in this manual.
2. Confirm all electrical, water and gas supplies are turned off at the source and the chimney/vent is clear of obstructions. If boiler is controlled by an external control system, this system must be temporarily disconnected. The local boiler controls should be allowed to operate the boiler.
3. Confirm that all manual shut-off valves between the boiler and gas supply are closed.

C. Power the Boiler

Turn on the electrical supply to the boiler and circulation system at fused disconnect switch. Ensure that the circuit breaker switch is in the "ON" position.

D. Power the Circulators

Turn system circulators on and purge air from the boiler and system piping.

E. Pressurize the Fuel System

1. Open the manual gas shut-off valves located upstream of the field supplied gas regulator. Do not open manual gas valve directly outside the boiler jacket.
2. Purge gas line of air.
3. Open manual ball valve outside boiler jacket. Confirm that the supply pressure to the manual ball valve tapping outside the boiler jacket conforms to Table 18 for maximum and minimum supply pressure.
4. Repeat Step 2 and Step 3 for boiler gas train components.

F. Boiler Commissioning

All of the installation instructions found in Sections I through VII shall be completed before commissioning the boiler.

⚠ DANGER

Failure to properly adjust excess air will result in unsafe levels of carbon monoxide. Variations in venting or combustion air pressure and temperature will change excess air. Adjust excess air levels so that variation in venting or combustion air pressures and temperatures caused by change of seasons, wind conditions, opening or closing of boiler room doors or windows do not cause the boiler to operate with carbon monoxide concentration above 400 parts per million.

1. Identify boiler water, gas, and electrical connections, and other safety controls.
2. Locate manometer pressure taps for pressure measurements in the following areas:
 - a. Supply gas pressure (*ball valve tapping outside of boiler top jacket panel*)
 - b. Stack or flue outlet pressure
3. Install a gas analyzer probe within 6" above the boiler flue gas outlet.
4. Verify the high temperature limit (auto reset) is set to 200° F. (*1000 only*)
5. Verify the high and low gas pressure switch limits.
 - a. High gas pressure switch at 1.0" w.c.
 - b. Low gas pressure switch at 3.0" w.c.
6. For Commissioning 1000 - 3000 go to Section G

G. Commissioning 1000 - 3000

1. Menu > Operation > Auto / Manual Rate Control > Manual (*76 password required*)
2. Switch boiler circuit breaker in the control panel to the ON Position (*1000 only*).
3. Close the manual gas valve between the automatic gas valve and the blower inlet.
4. Cycle the boiler. The boiler should lockout on gas pressure failure. In this case it should be the low gas pressure switch.
5. Reset the low gas pressure switch and gas pressure lockout.
6. Increase the high gas pressure switch setting to 14" w.c.
7. Cycle the boiler. The boiler should lockout on flame failure or ignition failure. (*Boiler may recycle once if there was an ignition failure.*)
8. Reset the flame failure lockout and decrease the high gas pressure setting to 1" w.c.

9. Cycle the boiler. The boiler should lockout on gas pressure. In this case it will be the high gas pressure switch.
10. Open the manual gas valve between the automatic gas valve and the blower inlet.
11. Reset the high gas pressure switch and gas pressure lockout.
12. Cycle the boiler. The boiler should establish main flame.
13. If flame is not established reset the flame failure lockout and repeat Step 12. (*Consult with the factory for assistance if flame cannot be established after 3 attempts.*)
14. Menu > Operation > High/Low > High > Back Arrow (*76 password required*)
15. While boiler is running at high fire, adjust supply gas pressure between 4" w.c. and 14" w.c. as measured at the ball valve tapping outside of the boiler top jacket panel.
16. Adjust the high fire O₂ level within 5.0% to 7.0% with all jacket doors installed and front cabinet door closed.
 - a. O₂ level must be set at high fire with all jacket doors installed and front cabinet door closed
 - b. For best efficiency, standard O₂ should be set to 5.0% to 6.0%.
 - c. For boilers specified to be less than 20 ppm NO_x adjust the O₂ level within 6.5% to 7.0%.
 - d. For boilers specified to be less than 9 ppm NO_x adjust the O₂ level within 7.0% to 9.0%.
 - e. High fire O₂ levels are adjusted with the gas shutter valve located on the outlet of the gas valve (*Figure 13*).
 - i. Turn throttle screw toward the Plus (+) side to increase gas flow (*decrease O₂ level*).
 - ii. Turn throttle screw toward the Minus (-) side to decrease gas flow (*increase O₂ level*).
17. Adjust the low fire O₂ level within 5.5% to 6.0% with all jacket doors installed and front cabinet door closed.
 - a. Menu > Operation > High/Low > Low > Back Arrow (*76 password required*)
 - b. Low fire O₂ levels are adjusted with the offset screw (*Figure 13*).
 - i. Turn offset screw toward the Plus (+) side to increase gas flow (*decrease O₂ level*).

- ii. Turn offset screw toward the Minus (-) side to decrease gas flow (*increase O₂ level*).

⚠ WARNING

Improper adjustments to the low fire offset adjustment can lead to rough light-offs and nuisance flame failures.

18. Verify O₂ repeatability by commanding the boiler to high fire and low fire as many times as required
19. Once the boiler is operating within the specified high and low fire ranges, record emissions, flue draft, and other important data on the installation and startup report, see Appendix C.
 - a. CO should not exceed 200 ppm air free. (In event of high CO contact factory)
20. Perform tests on each of the components listed Table 27.

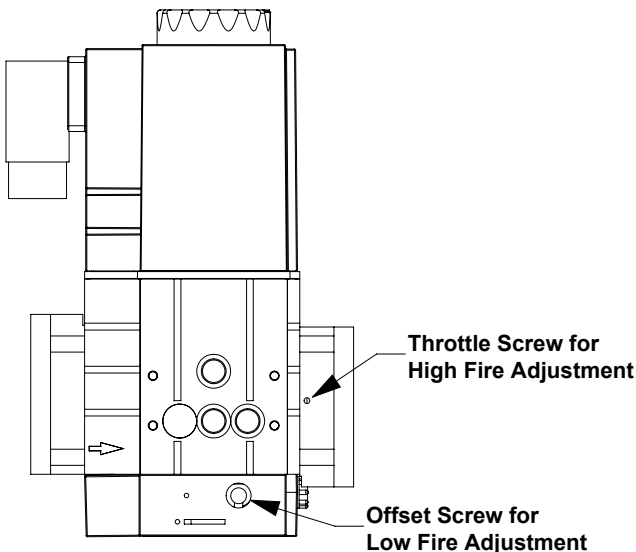

Figure 13: 1000-3000 Gas Valve

H. Commissioning 3500 - 6000 High Turndown

1. All steps listed in this section pertain to all high turndown 3500 - 6000 boilers unless specified.
2. All Commissioning and verifications are to be done in "Manual Mode".
3. Menu > Operation > Auto / Manual Rate Control > Manual (76 password required)

⚠ WARNING

Step 4 through Step 12 must be done as stated .

4. CLOSE the manual gas valve between the automatic gas valve and the blower inlet.
5. Cycle the boiler. The boiler should lockout on gas pressure failure. In this case it should be the low gas pressure switch, on 3500 - 6000 it could be the pilot low gas pressure switch, the main low gas pressure switch or both.
6. Reset the low gas pressure switch, also on the 3500 - 6000 reset the pilot low gas pressure switch and reset the gas pressure lockout.
7. Increase the high gas pressure switch setting to 14" w.c.
8. Cycle the boiler.
 - a. For 3500 - 6000, verify the pilot has lit then, the boiler should lockout on flame failure or ignition failure when switching to main flame. (*Boiler may recycle once if there was an ignition failure.*)
9. Reset the flame failure lockout and decrease the high gas pressure switch setting to 1" w.c.
10. Cycle the boiler. The boiler should lockout on gas pressure. In this case it will be the high gas pressure switch.
11. Open the manual gas valve between the automatic gas valve and the blower inlet.
12. Reset the high gas pressure switch and adjust to the setting listed in the Factory Fire Test report. Also, reset gas pressure lockout.
13. The combustion curve was preloaded and verified at the factory before shipment. (*It should not require advance adjustments with the LMV.*)
14. The Factory Fire Test report will indicate the SKP25 inlet and outlet gas pressures along with the O₂ readings used to set and test the combustion curve.
15. Cycle the boiler.
 - a. On 3500 - 6000 the pilot flame should be established and then main flame.
16. If flame is not established reset the flame failure lockout and repeat 15 (*Consult with the factory for assistance if flame cannot be established after 3 attempts.*)

⚠ WARNING

To PREVENT Burner Flashback

If O₂ level starts dropping and quickly goes below 4.7%, either adjust the SKP25 regulator counter-clockwise, a quarter turn at a time, to increase the O₂ or shut the boiler off to adjust.

If the O₂ drops below 4.0% immediately shut the boiler off, adjust the SKP25 a half turn counter-clockwise and restart the boiler (*boiler still might need more adjustment*).

17. Once main flame is established, leave boiler at low fire and observe that O₂ levels are within a safe operating range. (5.0% to 7.0%).
18. Once safe O₂ levels are established step the boiler from 0% to 100% monitoring the O₂. (0% on the Concert control is equal to 20% on the LMV AZL control)

NOTICE:

If low fire and/or high fire rates cannot be established or air switch issues, see Appendix B.

19. Once boiler has reached high fire rate, check that O₂ levels are within a safe operating range. (5.0% to 7.0%)
20. The O₂ can be shifted for the whole curve by increasing or decreasing the gas pressure with the boiler's SKP25 pressure regulator with all jacket panels installed and front cabinet door closed.
 - a. Adjust O₂ level within 6.0% to 7.0%.
 - b. For boilers specified to be less than 9 ppm NO_x adjust the O₂ level within 7.0% to 9.0%.
21. Verify O₂ repeatability by commanding the boiler from 0% to 100% and the intermediate points in between as many times as required, repeating Step 18 as necessary.
22. Once the boiler is operating within the specified high and low fire ranges, record emissions, flue draft, and other important data on the installation and startup report, see Appendix J.

NOTICE:

Advanced O₂ Adjustment - refer to the Siemens Manual, February 19, 2019 or later. (See *Siemens Website for manual*. <https://scccombustion.com/products/lmv3-linkageless-burner-management-system/>)

23. Perform tests on each of the components listed in Table 26.

I. Finish Commissioning the 1000 - 6000

Reconnect any wires from the external control system, if applicable.

1. Perform an operation test of the external control system.
2. Place system control back in normal operation, if necessary.
3. Place the boiler into automatic mode. Menu > Operation > Auto / Manual Rate Control > Automatic (76 password required)

J. Re-Starting After Prolonged Shutdown

Use the following recommendations prior to re-starting the heating system after prolonged shutdown.

1. Perform Pre-Start-Up Inspection by checking all gas, water, air intake and venting connections to ensure proper, leak-free connections and that the water and gas lines has been cleaned completely.
2. Ensure that combustion air piping, vent piping, and terminations are free of obstructions.
3. Inspect the boiler for damage and loose wire connections.
4. Remove all flammable material present in the vicinity of the boiler. S

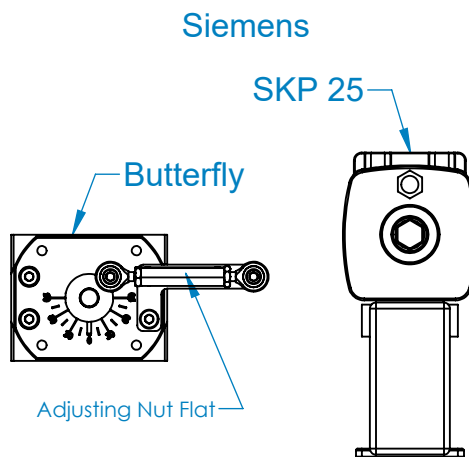

Figure 14: 3500-6000 Gas Valves

K. Testing Controls and Safety Devices

Prior to placing the boiler in operation, the installing contractor or other responsible personnel must perform safety and control device limit tests to ensure proper operation of the appliance. Refer to Table 26 for recommended method(s) of carrying out these safety limit devices tests.

Table 26: Safety Device Tests

Component	Test Method(s)	After Lockout Annunciation	Actual Alarm Message
High Gas Pressure Switch	Close the manual gas valve between the gas valve and air inlet. Cycle boiler.	Manually reset the Concert Boiler Control and switch. Adjust the switch to its normal setting.	Hard Lockout. Gas Pressure Switch
Low Gas Pressure Switch	Increase the setting of the switch until the switch trips.	Manually reset the Concert Boiler Control and switch. Adjust the switch to its normal setting.	Hard Lockout. Gas Pressure Switch
Blocked Condensate Switch	Disconnect one wire of the blocked condensate switch. Cycle the boiler.	Re-connect wiring to the blocked condensate switch. Reset blocked condensate switch lockout.	Hard Lockout Blocked Condensate Switch
Vestibule Thermal Fuse	Disconnect one wire of the vestibule thermal fuse. Cycle the boiler.	Re-connect wiring to the blocked condensate switch. Reset vestibule thermal fuse lockout.	Hard Lockout Vestibule Thermal Fuse
Low Water Cutoff	With the boiler running push and hold the LWCO test button until the boiler control shuts down the main burner.	Manually reset the Concert Boiler Control and reset the LWCO.	Hard Lockout. Low Water Level
Manual Reset High Limit Aquastat	With the boiler running, lower the setting of the Aquastat until the boiler control shuts down the main burner.	Adjust Aquastat back to 200° and press reset.	High Limit
Water Flow Switch	Reduce the water flow rate with a manual shutoff valve until the boiler shuts down.	Adjust manual valve to normal position.	Low Water Flow

L. Ignition Failure

After the first ignition failure, the boiler goes into a hard lockout and a manual reset of the Concert Boiler Control is required to restart the boiler. The boiler will then attempt to light off after it has completed its post-purge process.

⚠ DANGER

Contact the boiler manufacturer or a qualified heating service technician if the boiler has failed to light consecutively three times after initially resetting the Concert boiler control.

IX. Service, Maintenance, and Inspection

A. General Maintenance

1. Follow any checks and/or inspections that may be required as specified in the component manufacturers' instruction manuals.
2. Repair or replace any defective components immediately.
3. The following service procedures are required for proper and safe boiler operation.
4. Refer to Spare Parts manual included with the appliance for order numbers of replaceable parts. Most recent revisions of manuals and instructions can be found on factory website.

⚠ DANGER

This boiler uses flammable gas, high voltage electricity, moving parts, and very hot water under high pressure. Assure that all gas and electric power supplies are off and that the water temperature is cool before attempting any disassembly or service.

More than one gas shut-off valve and electrical disconnect switch are used on the boiler. Assure that all gas valves and electrical disconnect switches are off before attempting any disassembly or service.

Do not attempt any service work if gas is present in the air in the vicinity of the boiler. Never modify, removed or tamper with any control device.

Do not use matches, candles, open flames or other ignition source to check for leaks.

⚠ WARNING

This boiler must be serviced and repaired by skilled and experienced service technicians only.

If any controls are replaced, they must be replaced with identical models supplied by factory.

Read, understand and follow all the instructions and warnings contained in all the sections of this manual. The instructions and warnings contained in all of the component instruction manuals.

If any electrical wires are disconnected during service, clearly label the wire and ensure that the wires are reconnected properly.

Never jump out or bypass any safety or operating control or components of this boiler.

⚠ WARNING

Assure that all safety and operating controls and components are operating properly before placing boiler back in service.

⚠ WARNING

The service instructions contained in this manual are in addition to the instructions provided by the manufacturer of the boiler components. Follow component manufacturer's instructions. Component manufacturer's instructions were provided with the boiler. Contact component manufacturer or factory for replacement if instructions are missing. Do not install, start up, operate, maintain or service this boiler without reading and understanding all of the component instructions. Do not allow the boiler to operate with altered, disconnected or jumpered components. Only use replacement components identical to those originally supplied by the factory.

All cover plates, enclosures, and guards must be in place at all times, except during maintenance and servicing.

B. Daily

1. Make visual inspection of gauges, monitors, and indicators and record readings in boiler log.
2. Make visual check of instrument and equipment settings against factory recommended specifications.
3. Check operation of probe type low water cutoff(s) to ensure control is functioning.
4. Check gas train for gas leaks and water piping for any leaks.
5. Confirm boiler area is free of combustible materials and that there is nothing obstructing air intake and vent.

C. Weekly

1. Check combustion safety controls for flame failure (or other alarm messages).
2. Check all limit controls and low water cutoff as described above.
3. Check condensate drains for any obstructions.
4. Check carbon monoxide level in flue products.

D. Monthly

1. Check high and low gas pressure interlocks. Refer to manufacturer's instructions for correct procedure.
2. Check proper operation of safety relief valve.
3. Check water quality and correct if needed.
4. Inspect boiler air filter.

E. Annually

1. The flue gas passages and the exterior surfaces of the boiler tubes should be inspected at least once annually. Any accumulation of soot or debris should be thoroughly cleaned out.
2. If inspection of the boiler tube surfaces reveals a build-up of soot (*carbon*), the tube surfaces should be thoroughly brushed. Failure to do so may result in reduced efficiency, fire and asphyxiation hazards.
3. The boiler pressure vessel and piping should be checked annually.
4. Inspect the ignition rod for carbon build up.
5. Inspect lens of the ultra-violet (*UV*) scanner and remove any debris with soft cloth and make sure that hole is clear from scanner to burner.
6. Replace air filter.

F. Ignition Assembly Cleaning

1. Disconnect power and shut off the external manual gas valve to the boiler prior to removing the ignition assembly.
2. When removing the igniter, extra caution must be taken to prevent damaging the ceramic insulator.
3. Remove any excess oxide deposits from the surface of the igniter with steel wool. Do not use sandpaper, emery cloth or scotch brite pads.
4. Inspect the ceramic insulator for cracks, and if necessary, replace the igniter.
5. For the 1000-3000 see Figure 15.
 - a. Inspect igniter electrode. Ensure gap is $1/8'' \pm 1/32''$. Replace if spacing is outside range or cracks are observed.

- b. After each inspection of the igniter, replace gasket and apply anti-seize compound to mounting screws prior to reinstalling them.

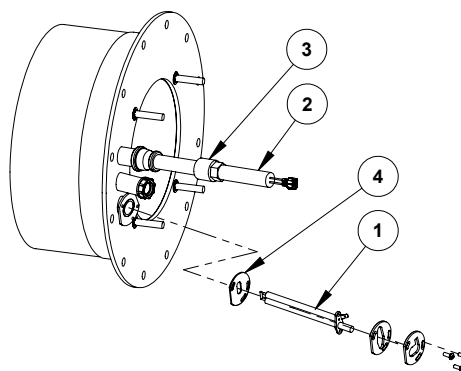
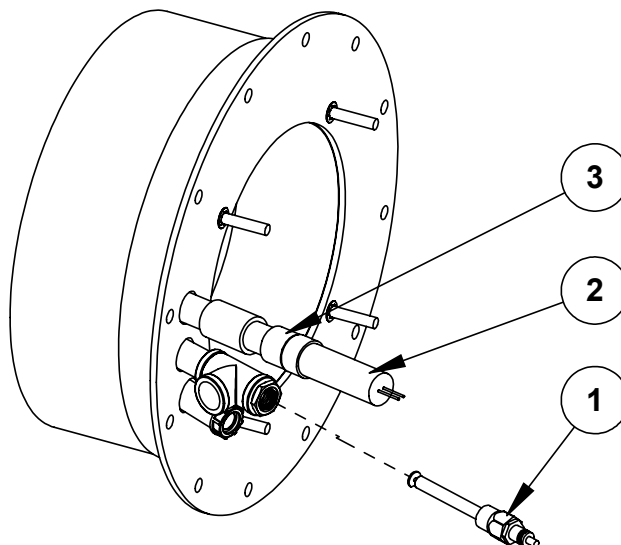

Figure 15: 1000-3000 Ignition Assembly

- 1. Igniter
 - 2. Ultra-Violet (*UV*) Scanner
 - 3. $1/2''$ Heat Insulator
 - Igniter Gasket
6. For 3500-6000 see Figure 16. After inspection of the igniter, apply anti-seize compound to igniter threads and replace the igniter, making sure the flat part along the edge of the disc is pointed down towards the base of the boiler.

Figure 16: 3500-6000 Ignition Assembly

- 1. Igniter
- 2. Ultra-Violet (*UV*) Scanner
- 3. $1/2''$ Heat Insulator



G. Burner Assembly Cleaning

1. After disconnecting power to the boiler, remove the boiler's furnace door. For part identification, refer to the parts manual.
2. Clean around the burner assembly by blowing compressed air over the surface of the burner to remove lint and debris accumulation. Be careful when cleaning the burner assembly, to avoid damaging the metal mesh burner surface.
3. If the burner or the burner gasket shows any visual deterioration or corrosion signs, replace it immediately.
4. After replacing the burner or burner gaskets, check for proper operation by performing combustion analysis, as well as checking for gas leakage around the burner mounting and blower transition pieces.

H. Heat Exchanger Cleaning

1. Perform visual inspection of both boiler flue passes, and remove any debris from the surfaces of the heat exchanger.
2. If necessary, brush the tubes of the heat exchanger using non-abrasive, non-metallic bristle brush.
3. Be careful not to damage or disturb the insulation inside of the heat exchanger.

I. Tube Replacement Procedure

NOTICE:

Performing a regular boiler inspection will prolong the life of the heat exchanger, and ensure optimal function and energy efficiency. For best practices, adhere to the general guidelines outlined in the service and maintenance section of this manual.

1. Inspect the boiler. Use the following steps to identify a potential tube leak and to minimize possible damage to the boiler and other equipment as a result of tube failures.
 - a. Shut off power to the boiler immediately from the external, dedicated electrical disconnect.
 - b. Confirm that any water leakage is not the result of a blocked condensate drain line.
 - c. Confirm that any water leakage is not the result of a blocked condensate drain line.

- d. Remove the boiler's left side jacket panels and flue collector access panels as shown in Figure 17, Figure 18, and Figure 19.
 - e. Visually inspect the burner and furnace pass insulation for water damage. If significant water damage to the insulation or burner is observed, contact the manufacturer.
 - f. Identify any leaking tubes.
 - g. Isolate and drain the boiler completely.
2. Use the proper tools. Use the following tools to remove and replace leaking boiler tubes:
 - a. Tube Puller (*P/N 106019-02*)
 - b. Tube Driver (*P/N 106019-01*)
 - c. Sledgehammer (*steel head, approximately 3 lb*)

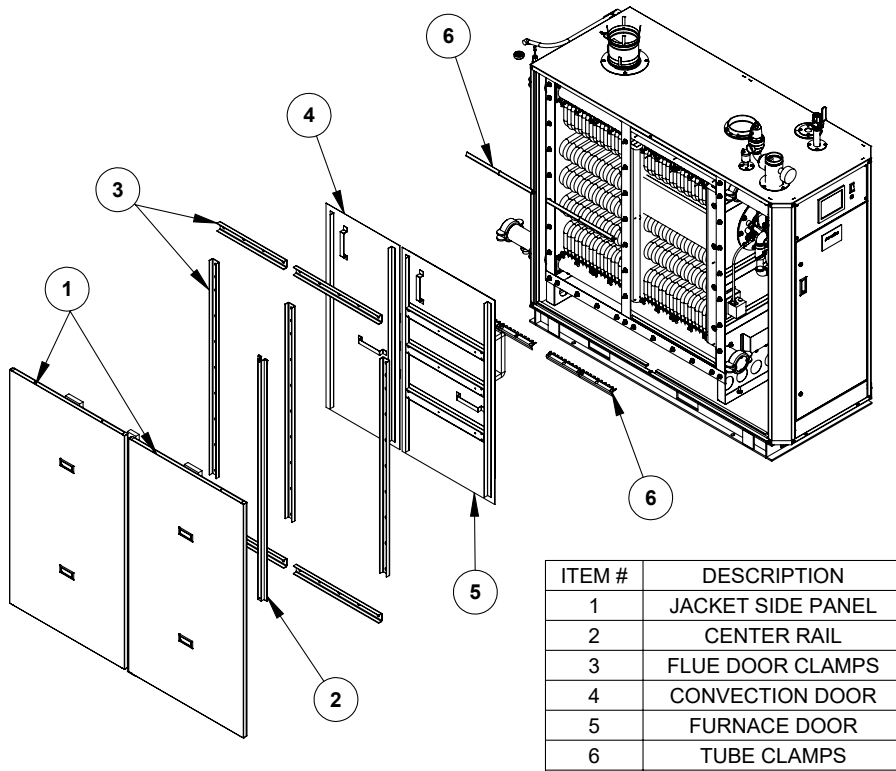

Figure 17: Panel Removal in Preparation for Tube Inspection - 1000

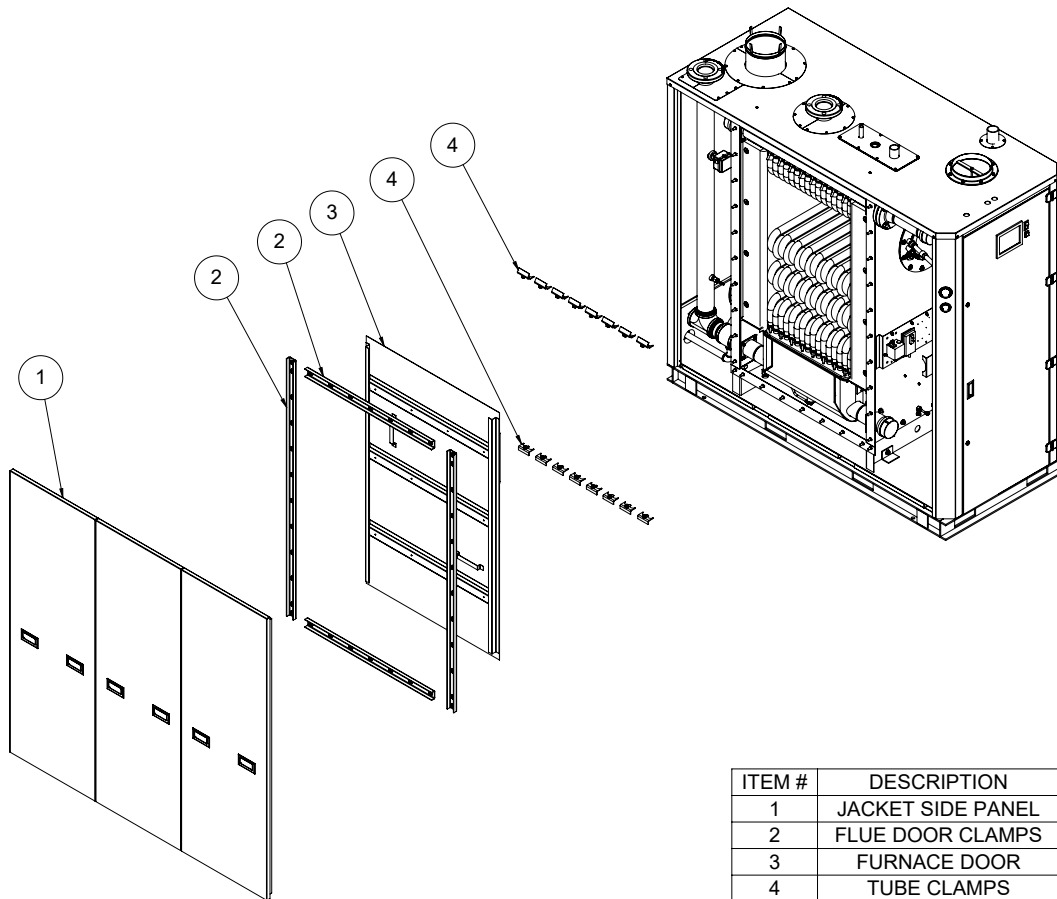

Figure 18: Panel Removal in Preparation for Tube Inspection - 1500 - 3000

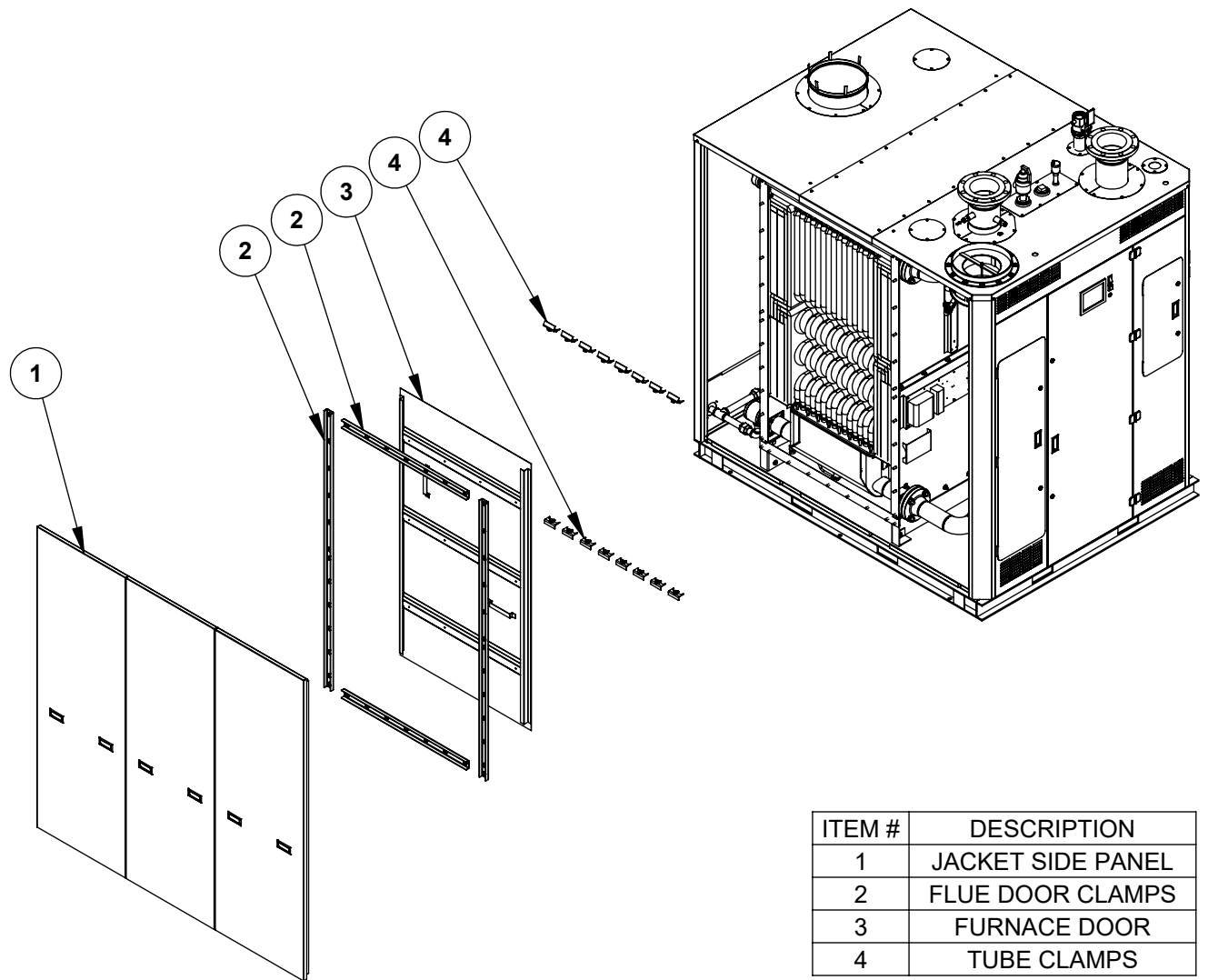

Figure 19: Panel Removal in Preparation for Tube Inspection, 3000 - 6000

*Note: Tubes are accessed and serviced from both sides of the 3500 - 6000 Boilers.
(Right side exploded view not shown.)*

4. Loosen tube-ends. Insert tube puller between the tube-end and header. Apply pressure to the puller and strike the side of the tube two or three times with a hammer to help loosen the tube-end in the upper and lower header.
5. Pull lower tube end. Wedge the tube puller under the flange of the tube. Drive the tube puller with several blows with a hammer on the end of the handle. Alternate with downward blows to lift tube-end.
6. Clear tube-end from the header. Continue driving wedge under and leveraging flange up until it pops the end of the tube free from the hole in the header.
7. Pull upper tube-end. Repeat the procedure to pull the tube-end of the same tube from the upper header.

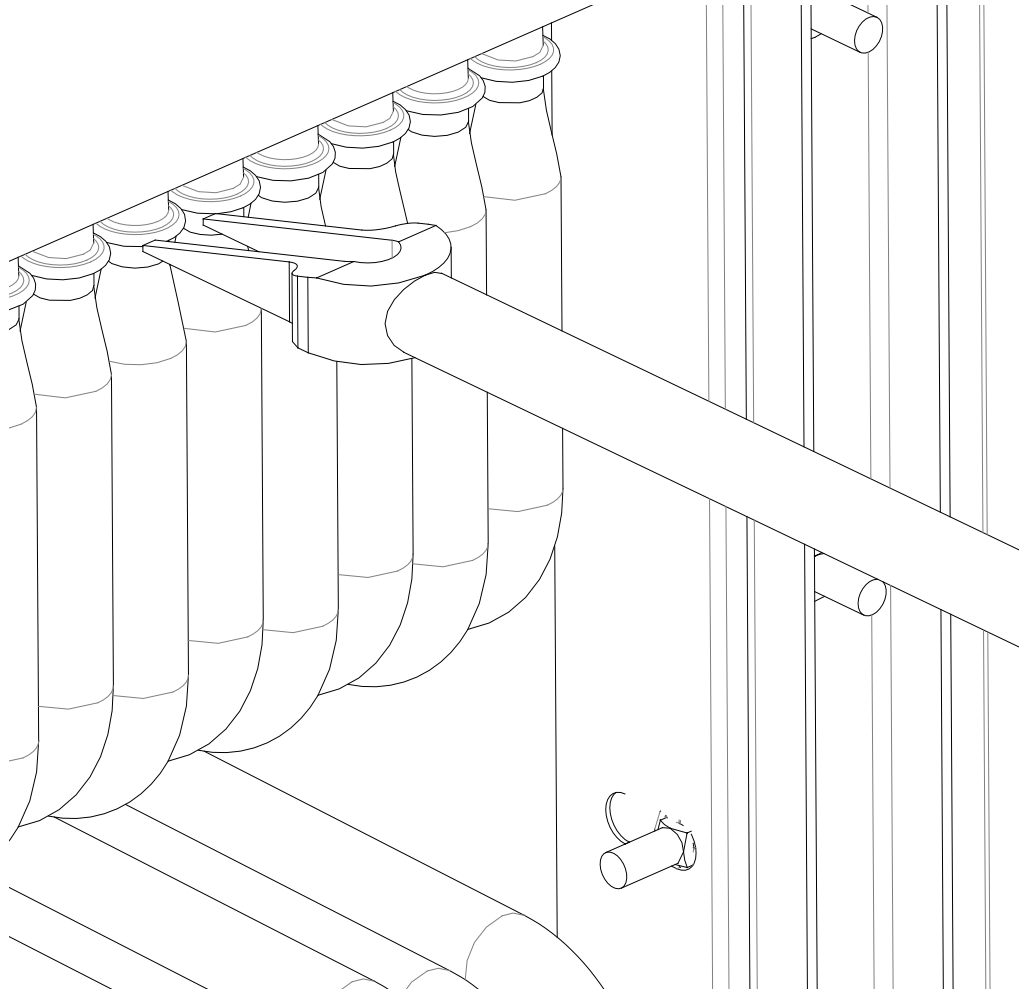

Figure 20: Tube Puller Insertion

8. Prepare the headers and replacement tubes. Before placing a new tube into the header, clean the holes by wiping gently with emery cloth to be sure that there are no burrs. Clean the replacement tube-ends of any rust or debris. With a small brush, apply a thin coating of gray pipe dope around the inside of the hole. Pipe dope may also be applied to the tube-end. Cutting oil may be mixed with the pipe dope for easier application.
9. Insert both ends of the tubes into the headers. Insert the lower tube-end into the bottom header first. Then insert the top tube-end into the top header. Insert all replacement tubes before driving them.
10. Drive the upper and lower tube-ends. DO NOT drive the tube-ends down to the flange. With the driver tool positioned on the flange, strike the end of the driver with hammer. After a few hits, the feel of the strike will become solid. The tone will also change from a “Ting” sound to more of a “Tong” sound. This indicates the tube has seated.

⚠ CAUTION

Do Not Overdrive Tubes! Overdriving tubes can cause damage to the tubes and boiler header holes. Use only approved factory tube driver and specified hammer. The end-formed tube fitting is designed to deform if overdriven to minimize damage to the vessel tube holes.

11. Reinstall the tube clamps. Replace the nuts and flat washers if damaged in any way. Use brass nuts only! Tighten the nuts until snug. Do not try to compress the tube-ends into the holes with the clamps, because the clamps might break or the stud might shear.
12. Inspect flue collector panel gaskets for damage. Replace gaskets if damaged to prevent leaking. Gaskets can normally be reused.
13. Refill the boiler. Fill the unit with water and ensure that there is no leakage at the replacement tube-ends before reinstalling the flue collector panels.

⚠ WARNING

If a leak is detected after a replacement tube has been installed, pressure in the boiler must be reduced to zero before adjusting tube(s). Adjusting tubes under pressure could result in serious personal injury.

14. Reinstall all flue access doors, door clamps, and jacket panels.
15. Perform startup check prior to putting boiler back into operation.

J. Safety and Operating Controls

All of the safety control devices listed in Table 27 are logically linked to the Concert Boiler Control that supervises the sequence of operation of the boiler for safe and efficient operation. It does so by ensuring proper light off and firing of the main burner and if need be, will immediately cut-off gas supply to the main burner when gas pressure, water temperature, water flow or another critical attribute is outside of the operational settings. It also varies the combustion rate in real time to meet the desired load of the system.

⚠ WARNING

Do not install, operate, service or repair any components of this equipment unless you are qualified and fully understand all requirements and procedures. Trained personnel should refer to those who have completed factory Service School training specific to this product.

Table 27: Safety and Operating Controls

Component	Function
<i>Power Switch</i>	If this switch is in the off position, power is interrupted to the control circuit of the boiler, which prevents the boiler from operating. If the switch is in the on position, power is supplied to the control circuit.
<i>Automatic Reset Operating Aquastat</i>	If the boiler water temperature exceeds the adjustable set point, power is interrupted to the control circuit of the boiler, which prevents the boiler from operating. When the boiler water temperature drops below the set point minus the adjustable differential setting, power is again supplied to the control circuit.
<i>Manual Reset High Limit Aquastat</i>	If the boiler water temperature exceeds the adjustable set point, power is interrupted to the control circuit of the boiler, which prevents the boiler from operating. Power is interrupted until the control is manually reset pressing the control's reset button. When the button is pressed, power will again be supplied to the control circuit, assuming that the boiler water temperature has dropped below the setpoint minus the differential setting.
<i>Water Flow Switch</i>	If the water flow through the boiler drops below the fixed flow rate required to move the control's paddle enough to close the control's contacts, power is interrupted to the control circuit, which prevents the boiler from operating. When the water flow rate increased, the paddle closes the control's contacts and power is supplied to the control circuit.
<i>Pressure / Safety Relief Valve</i>	If the pressure inside the boiler exceeds the fixed set point, the valve opens mechanically and discharges water. The valve remains open until the pressure inside the boiler drops below the set point.
<i>High and Low Gas Pressure Switches</i>	If the gas pressure reaches a point above or below the adjustable set point, the contacts of the switch open and power is interrupted to the control circuit that prevents the boiler from operating. Power is interrupted until gas pressure is between the high and low gas pressure set points and the control is manually reset moving the switch to the reset position. The switches will not reset until the gas pressure is within the set point parameters.
<i>Minimum Air Pressure Switch</i>	If the differential air pressure drops below the fixed set point, the contacts of the switch open and power is interrupted to the control circuit, which prevents the boiler from operating. Power is interrupted until air flow/pressure increases so that contacts close.
<i>Maximum Air Pressure Switch</i>	If the differential air pressure exceeds the fixed set point, the contacts of the switch open and power is interrupted to the control circuit, which prevents the boiler from operating. Power is interrupted until air flow/pressure decreases below the setting so that the contacts close.

K. Troubleshooting

Refer to the troubleshooting section in the Concert Boiler Control manual on how to navigate the Limit String Status screen that shows an active safety limit status and for an in-depth guide to all the possible lockouts as well as recommended corrective actions for restore boiler operation.

For High Turndown 1500-6000 boilers display issues, contact you Sales Rep for the latest PLC and Display updates. If you don't know who your sales rep is, call the number listed at the bottom of the page.

Table 28: General Troubleshooting

INDICATION	POSSIBLE CAUSE	CORRECTIVE ACTION
<i>Boiler is not responding to a call for heat, "Status" and "Priority" show "Standby".</i>	Boiler is not seeing Enable/Disable of Domestic Demand Input.	Check wiring for loose connections or wiring errors. If Domestic Demand is expected check the DHW Demand/Modulation is selected properly.
<i>Boiler is not responding to call for heat, "Status" shows "Standby" and "Priority" shows Central Heat or Domestic Hot Water.</i>	Boiler is not firing, or temperature is greater than setpoint.	Select display Help icon and review Limit String Status.
<i>Boiler is Running but System or Boiler Circulator is not running.</i>	Pump Not Running.	Check wiring for loose connections or wiring errors. When there is a Domestic Hot Water Heat Request the System or Boiler Pump will be forced "off" when their "Run Pump for" parameter is set to "Central heat, off DHW demand" or "Central Heat, Optional Priority". This has been set to allow all of the heat to be provided for fast indirect water heater recovery. After "Priority protection" time or the end of the Domestic Hot Water Heat Request the system and boiler pumps will be free to run.
<i>Display Completely Dark Fan off, LWCO lights off, no green power light on Control.</i>	No 120 Vac Power at Boiler due to blown high voltage fuse or circuit breaker trip.	Check breaker and wiring between breaker and boiler. Replace blown high voltage fuse. Reset tripped breaker.
<i>Display Completely Dark, Fan running.</i>	No 120 Vac Power at Control; No 24 Vdc to Display.	Check for loose 120 Vac connection wiring between boiler J-Box and transformer or 24 Vdc power supply. Check for loose 24 Vac connection wiring between transformer and Control. Check blown low voltage fuse: Replace if necessary. Check for bad transformer or bad 24 Vdc power supply: Replace if necessary.
<i>Blinking Green power light on Control.</i>	Control Fault.	The green light is connected to internal power supply. The power supply is repeatedly starting and stopping (not normal) making the light flash. The microprocessors are not running. Try disconnecting all terminals except 24 Vac to power the control. The green light should be steady. If it is not, then the control is defective. If steady, start plugging in all the connectors while watching the green light. When the faulty wiring reconnected, green light will begin to flash.
<i>Blank Screen with "Reading" shown.</i>	Display lost communication with Control.	Failure to establish Communication upon boot-up once you establish communication, reboot display to read controller and setup display properly.
<i>Communication Error 2</i>	Un-configured control, or control has a memory failure.	The display-write attempt has failed. The controller is un-configured or has a memory failure. Lockout 20 Safety Data Verification will also be displayed. Replace Control.
<i>Communication Error 3</i>	Communication Fault.	Display has lost communication with controller. Check for loose or defective display harness, defective display or defective control. Refer to Concert Boiler Control manual for more details.
<i>Short Cycling</i>	Oversized Boiler	Examine system and boiler operational settings to determine what adjustments may be made to reduce boiler cycling. Contact Manufacturer.
	Incorrect Gas Valve Settings	If combustion is too lean or rich as a result of improper gas valve settings, adjust air-fuel ratio to match factory O2 settings.
<i>Poor Combustion</i>	Dirty Heat Exchanger	Inspect heat exchanger tubes for damage and carbon build-up. Inspect and clean the burner assembly. Refer to the Service, Maintenance and Inspection section of the manual for guidance.
	Leakage	Remove the boiler's side panels and check for flue gas leakage around the heat exchanger, burner mounting plate, and blower transition piece.

Appendix A: Sizing Gas Piping

Design the gas piping system to provide an adequate gas supply to the boiler. Refer to Table 18 for minimum and maximum gas supply pressures and boiler capacities. Also consider existing and expected future gas utilizing equipment (*i.e., water heater, cooling equipment*). Refer to Table 29 for maximum capacity of schedule 40 pipe. Table 30 lists equivalent pipe length for standard fittings. Given the specific gravity of gas at the boiler's location, a correction factor can be found on Table 31 and multiplied by the "Capacity in Cubic Feet of Gas Per Hour" in Table 29. For gas piping material other than schedule 40 pipes, refer to the National Fuel Gas Code, NFPA 54/ANSI Z223.1 and/or CAN/CGA B149 Installation codes. Use methods and materials in accordance with Local Codes and requirements of gas supplier. In the absence of such requirement follow National Fuel Gas Codes, NFPA /ANSI Z 223.1 and/or CAN/CGA B149 Installation Codes.

Table 29: Maximum Gas Capacity Of Schedule 40 Pipe

Pipe Length in Equivalent Feet	Pipe Size (NPT)							
	$\frac{3}{4}$	1	1-1/4	1-1/2	2	2-1/2	3	4
10	273	514	1060	1580	3050	4860	8580	17500
20	188	353	726	1090	2090	3340	5900	12000
30	151	284	583	873	1680	2680	4740	9660
40	129	243	499	747	1440	2290	4050	8270
50	114	215	442	662	1280	2030	3590	7330
60	104	195	400	600	1160	1840	3260	6640
70	95	179	368	552	1060	1690	3000	6110
80	89	167	343	514	989	1580	2790	5680
90	83	157	322	482	928	1480	2610	5330
100	79	148	304	455	877	1400	2470	5040
125	70	131	269	403	777	1240	2190	4460
150	63	119	244	366	704	1120	1980	4050
175	58	109	224	336	648	1030	1820	3720
200	54	102	209	313	602	960	1700	3460

Based on gas pressures less than 2 psig and a pressure drop of 3.0 iwc and 0.6 specific gravity.

Table 30: Equivalent Lengths Of Standard Pipe Fittings And Valves

Pipe Size (<i>NPT</i>)	ID (<i>in.</i>)	<i>Valves Fully Open (Screwed, Flanged, Welded) (eq. ft)</i>				<i>Schedule 40, Screwed Fittings (eq. ft)</i>		
		Gate	Globe	Angle	Swing Check	90 deg. Elbow (<i>threaded</i>)	45 deg. Elbow (<i>threaded</i>)	90 deg. Tee, Flow Through Branch (<i>thread- ed</i>)
1/2	.622	.36	17.3	8.65	4.32	1.55	.73	3.1
3/4	.824	.48	22.9	11.4	5.72	2.06	.96	4.12
1	1.049	.61	29.1	14.6	7.27	2.62	1.22	5.24
1-1/4	1.38	.81	38.3	19.1	9.58	3.45	1.61	6.9
1-1/2	1.61	.94	44.7	22.4	11.2	4.02	1.88	8.04
2	2.067	1.21	57.4	28.7	14.4	5.17	2.41	10.3
2-1/2	2.469	1.44	68.5	34.36	17.1	6.16	2.88	12.3
3	3.068	1.79	85.2	42.6	21.3	7.67	3.58	15.3
4	4.026	2.35	112	56	28	10.1	4.7	20.2
6	6.065	3.54	168	84.1	42.1	15.2	7.07	30.4

Equivalent lengths are for standard screwed fittings and for screwed, flanged, and welded valves relative to schedule 40 steel.

Table 31: Specific Gravity Correction Factors

Specific Gravity	Correction Factor
0.5	1.1
0.55	1.04
0.6	1.0
0.65	0.96
0.7	0.93
0.75	0.9
0.8	0.87
0.85	0.84
0.9	0.82
1.0	0.78
1.1	0.74

Appendix B: Air Switch Adjustment 1500-6000

5. Temporary Air Switch adjustments are to be done if P1 and P9 firing rates cannot be established. **Do NOT** leave this Step 1 as the final setting, proceed to Step 2 after firing rates have been established.
 - a. If blocked flue switch won't allow the P9 firing rate to be established, turn clockwise in half turn increments until boiler will run at P9 with the proper firing rate.
 - b. If low pressure air switch won't allow P1 firing rate to be established, turn counter-clockwise in half turn increments until boiler will run at P1 with the proper firing rate.
6. Air Switch adjustment is to be done after P1 and P9 firing rates have been established. The Boiler should be in Standby and use the AZL23 to program the LMV3. Log in to the AZL23, by holding down the F and A buttons together until "CodE" is displayed. The OEM password is: "EntrY". Press the up or down arrow until the proper letter is displayed and press Enter. Repeat the process until "EntrY" has been completed. Continue to press enter again until 400 is displayed to complete log in. Advance to the Parameter 500 series.
 - a. Blocked Flue Air Switch
 - i. Set Parameters 502:00 (Air) and 503:00 (VSD), to match P9's – Air and VSD settings. After pressing Enter, the Air Damper and VSD will adjust to these settings.
 - ii. Use a Multimeter set to Ohms or Continuity. With Multimeter leads placed on the switch terminals, turn air switch adjustment slowly counter-clockwise, until the circuit opens.
 - iii. With Multimeter leads still in place, turn air switch adjustment slowly clockwise, until the circuit closes.
 - iv. Remove leads and turn the air switch adjustment an additional, one full turn clockwise.
 - v. Reset Parameters 502:00 (Air) and 503:00 (VSD) back to "0".
 - b. Low Pressure Switch
 - i. Set Parameter 502:00 (Air), to match P1's – Air setting.
 - ii. Set Parameter 503:00 (VSD), to match P1's – VSD setting, less 10 percentage points lower than P1's. (e.g. If VSD at P1 is set to 40.0 then set Parameter 503:00 to 30.0)
 - iii. Use a Multimeter set to Ohms or Continuity. Place Multimeter leads on the air switch terminals and determine, if the circuit is open or closed.

Open Circuit – turn air switch adjustment slowly clockwise, until circuit closes. Go to Step iv.

Closed circuit – turn the air switch counter-clockwise until circuit opens. Go to Step v.
 - iv. Next, turn air switch adjustment slowly counter-clockwise, until the circuit opens.
 - v. Reset Parameters 502:00 (Air) and 503:00 (VSD) back to "0".

Appendix C: Venting Diagrams

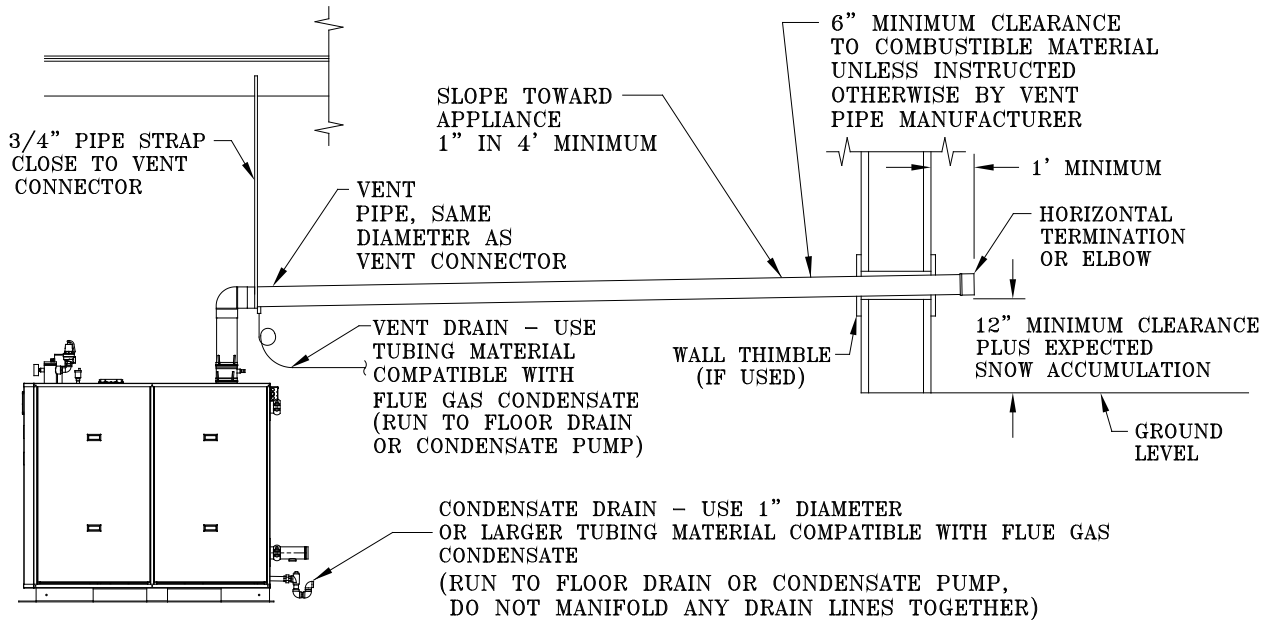

Figure 21: Typical Horizontal Vent Piping

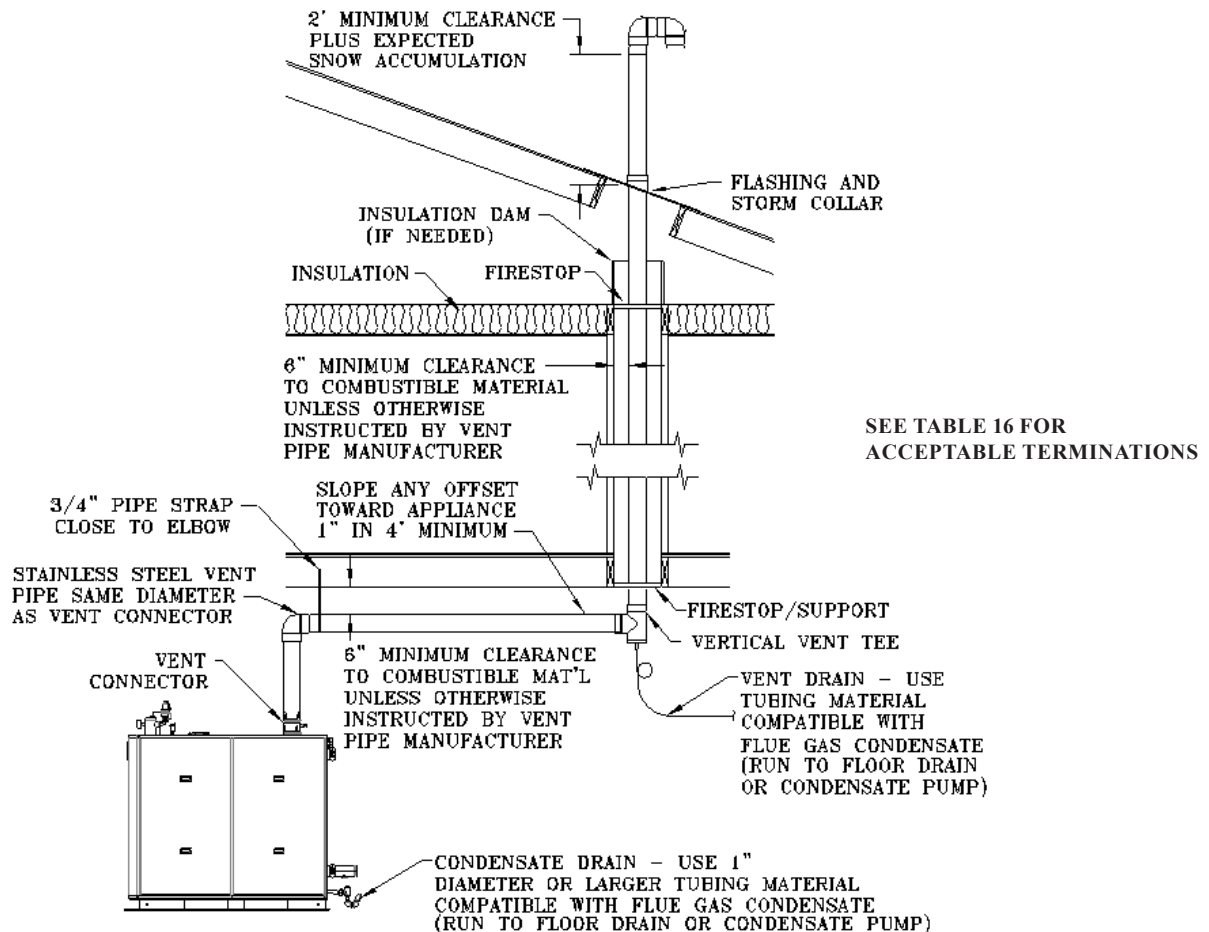

Figure 22: Typical Vertical Pressurized Venting

Appendix D: Combustion Air Diagrams

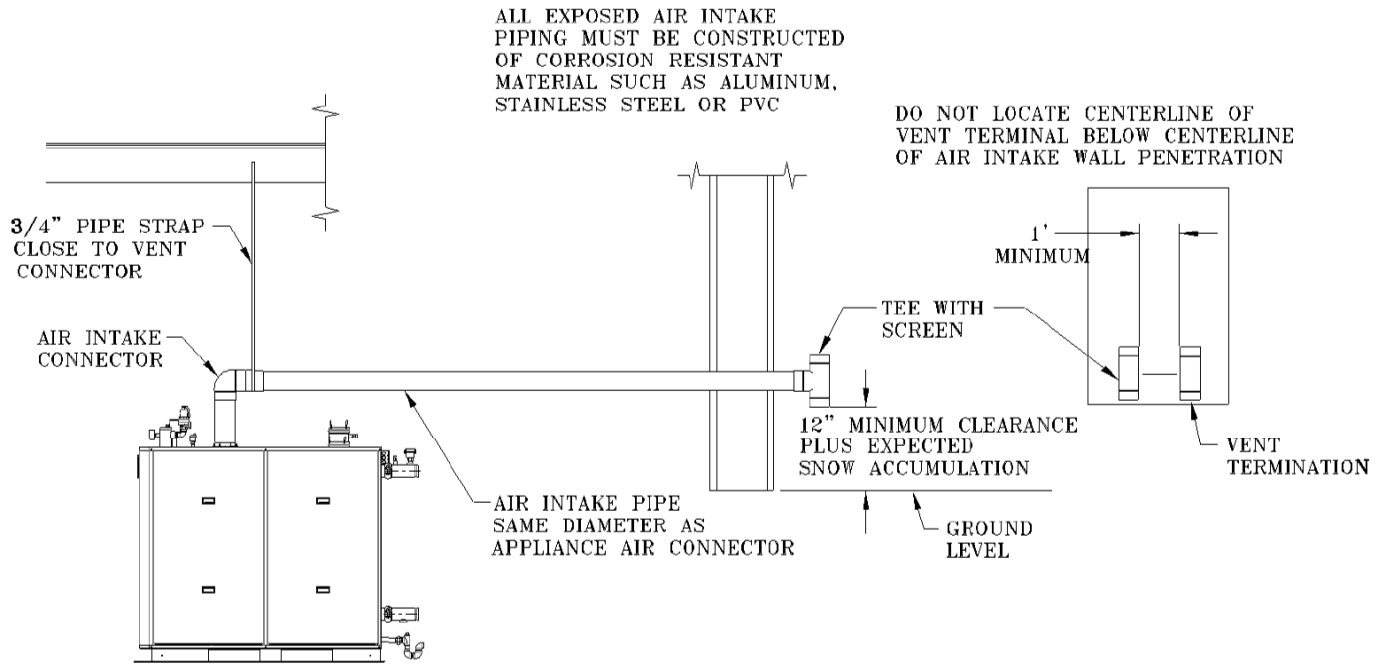

Figure 23: Typical Horizontal Air Intake Piping

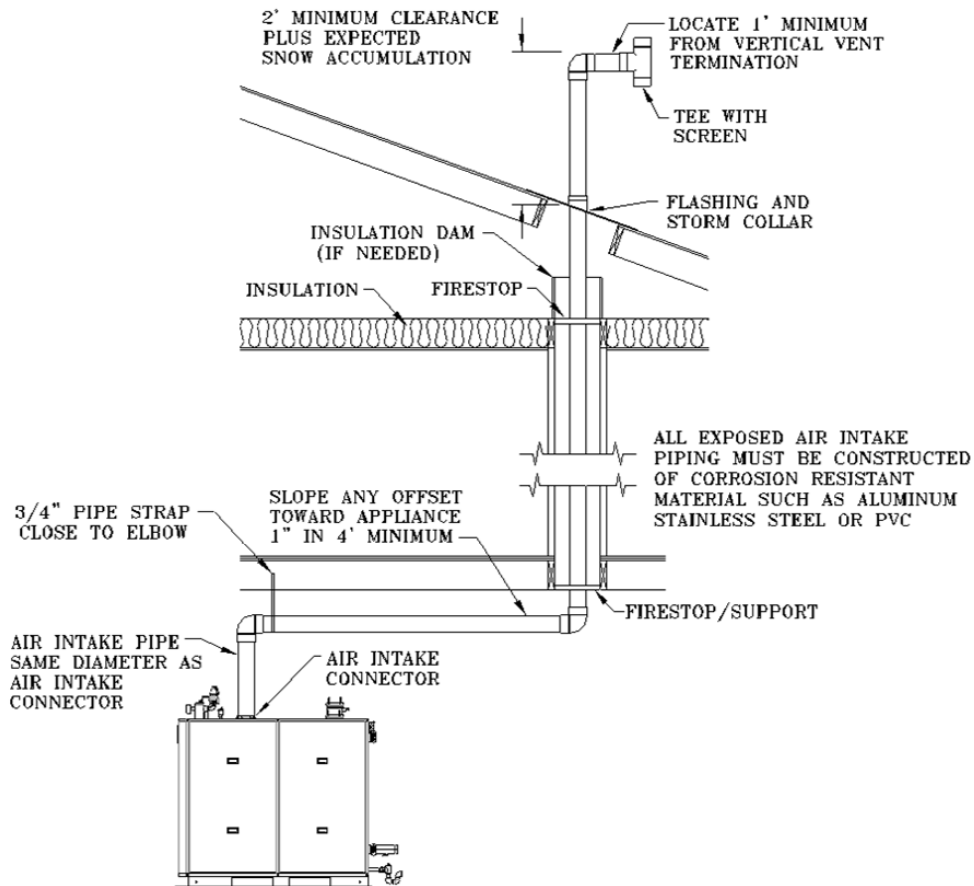

Figure 24: Typical Vertical Air Intake Piping

Appendix E: Boiler Piping Diagrams

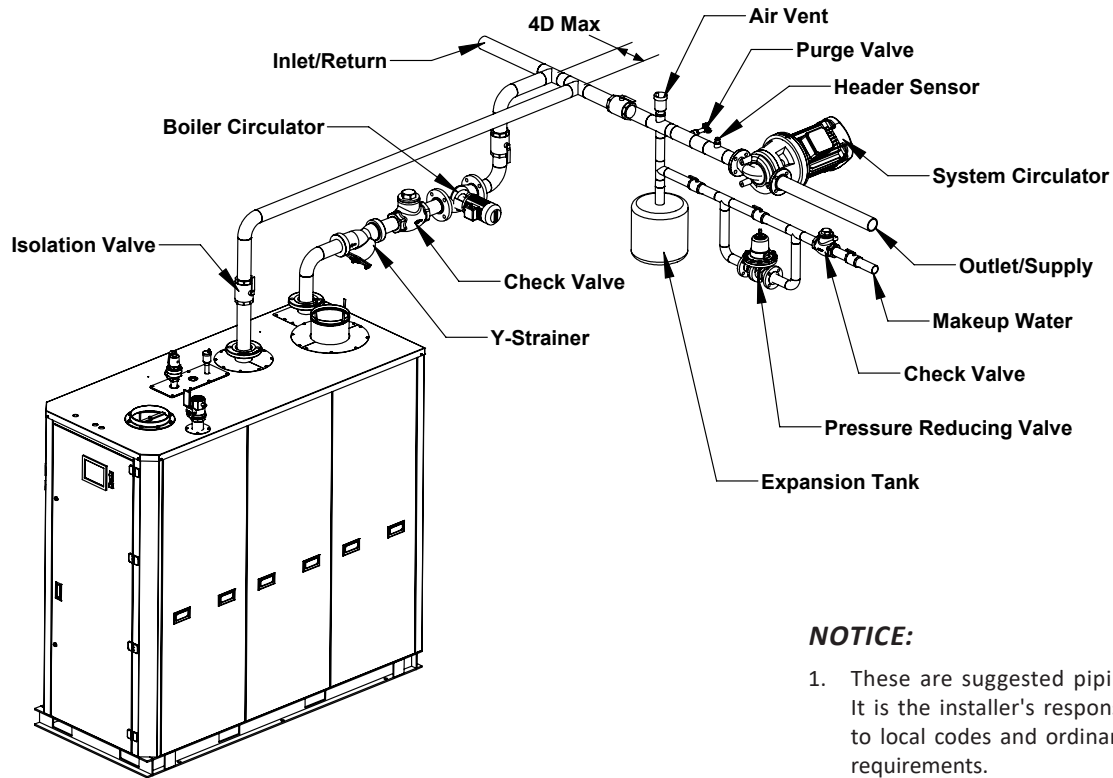

Figure 25: Single Boiler, Primary / Secondary

NOTICE:

1. These are suggested piping configurations. It is the installer's responsibility to conform to local codes and ordinances for additional requirements.
2. Pressure relief valve rating shall not exceed pressure rating of any component in the system.
3. Some piping components cannot be supported by the piping. Refer to the manufactures' installation instructions.
4. Circulation pump must be sized to overcome the pressure drop across the entire loop.

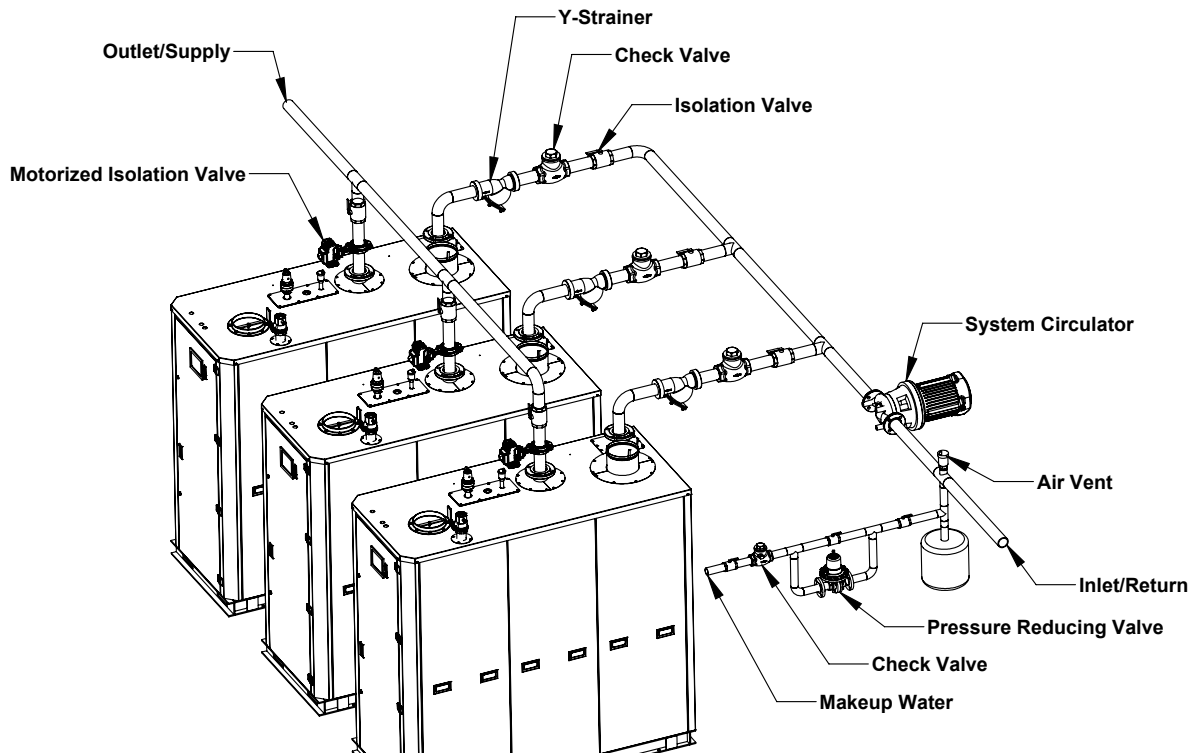

Figure 26: Multiple Boilers, Primary Reverse-Return Piping

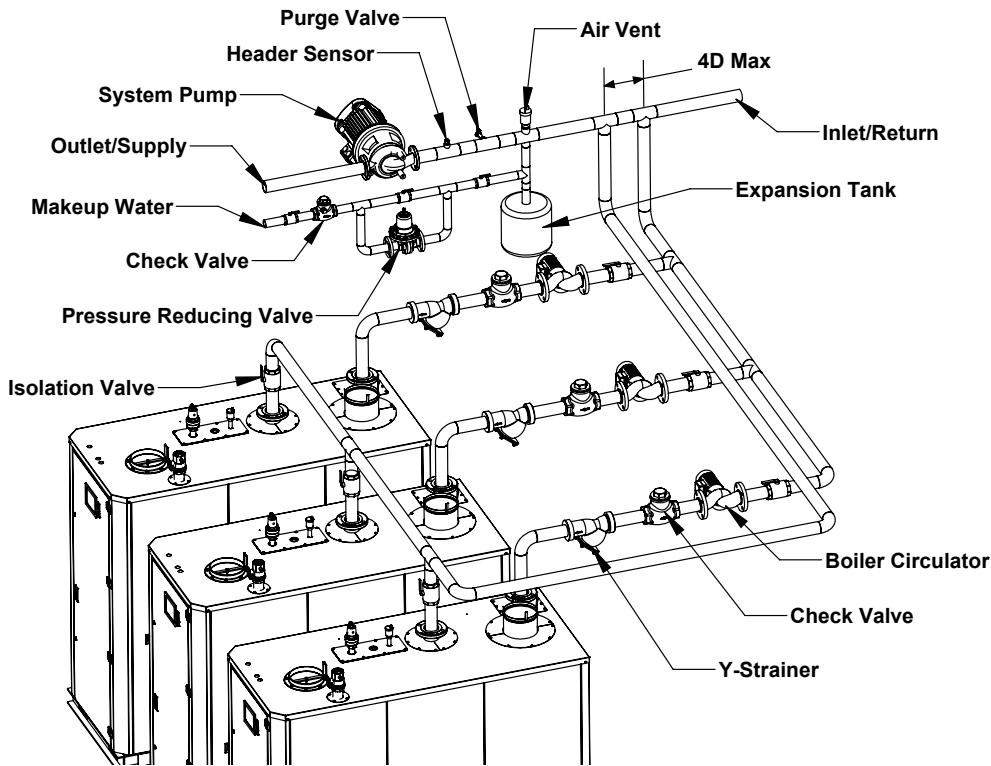
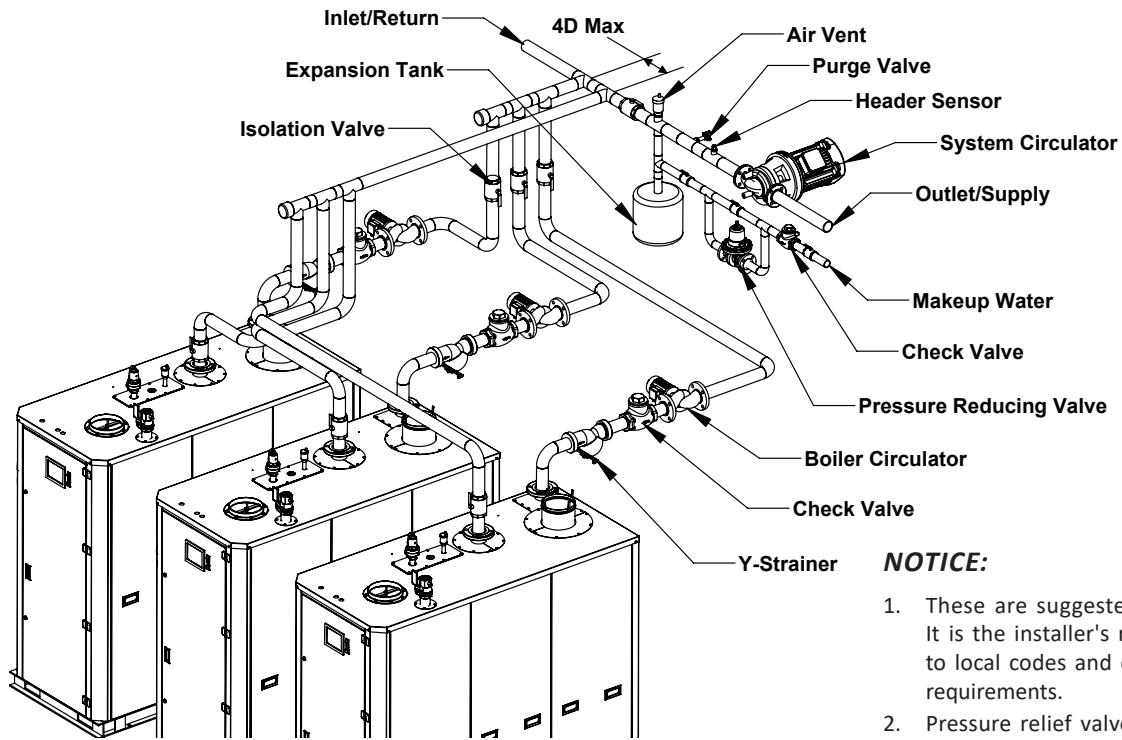

Figure 27: Multiple Boilers, Primary / Secondary Reverse Return Piping



NOTICE:

1. These are suggested piping configurations. It is the installer's responsibility to conform to local codes and ordinances for additional requirements.
2. Pressure relief valve rating shall not exceed pressure rating of any component in the system.
3. Some piping components cannot be supported by the piping. Refer to the manufactures' installation instructions.
4. Circulation pump must be sized to overcome the pressure drop across the entire loop.

Figure 28: Multiple Boilers, Primary / Secondary Piping

NOTICE:

1. These are suggested piping configurations. It is the installer's responsibility to conform to local codes and ordinances for additional requirements.
2. Pressure relief valve rating shall not exceed pressure rating of any component in the system.
3. Some piping components cannot be supported by the piping. Refer to the manufactures' installation instructions.
4. Circulation pump must be sized to overcome the pressure drop across the entire loop.

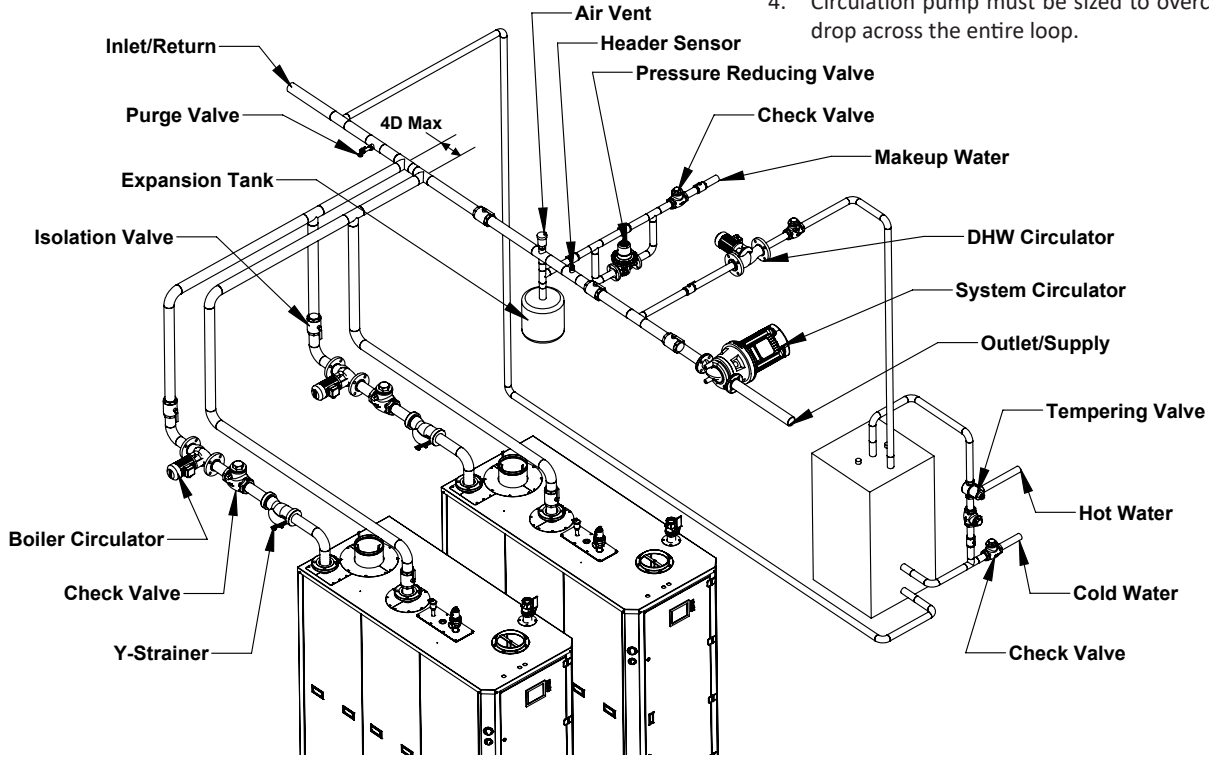

Figure 29: Multiple Boilers, Primary / Secondary With Indirect Water Heater

Table 32: Required Common Piping Sizes for Multiple Appliances

Model	Number of Appliances				
	2	3	4	5	6
1000	3"	3.5"	4"	5"	5"
1500	3.5"	4"	5"	6"	6"
2000	4"	5"	6"	6"	8"
2500	5"	6"	6"	8"	8"
3000	5"	6"	8"	8"	10"
3500	5"	8"	8"	8"	10"
4000	6"	8"	8"	10"	10"
4500	6"	8"	10"	10"	10"
5000	6"	8"	10"	10"	12"
5500	8"	8"	10"	10"	12"
6000	8"	10"	10"	12"	12"

Note: Nominal pipe sizes are noted. Based on schedule 40 steel.

Appendix F: Water Flow Pressure Drops

1000			1500			2000			2500			
<i>Delta T</i>	<i>GPM</i>	<i>Ft. Hd.</i>	<i>Delta T</i>	<i>GPM</i>	<i>Ft. Hd.</i>	<i>Delta T</i>	<i>GPM</i>	<i>Ft. Hd.</i>	<i>Delta T</i>	<i>GPM</i>	<i>Ft. Hd.</i>	
100F	19	0.51	100F	29	0.37	100F	38	0.65	100F	48	0.80	
90F	21	0.63	90F	32	0.45	90F	42	0.80	90F	53	0.99	
80F	24	0.79	80F	36	0.58	80F	48	1.02	80F	59	1.25	
70F	27	1.04	70F	41	0.75	70F	54	1.33	70F	68	1.63	
60F	32	1.41	60F	48	1.02	60F	63	1.81	60F	79	2.22	
50F	38	2.03	50F	57	1.47	50F	76	2.61	50F	95	3.20	
45F	42	2.51	45F	63	1.82	45F	84	3.22	45F	106	3.95	
40F	48	3.18	40F	71	2.30	40F	95	4.08	40F	119	5.00	
35F	54	4.15	35F	81	3.00	35F	109	5.32	35F	136	6.53	
30F	63	5.64	30F	95	4.09	30F	127	7.24	30F	158	8.89	
25F	76	8.13	25F	114	5.89	25F	152	10.43	25F	190	12.80	
20F	95	12.70	20F	143	9.20	20F	190	16.30	20F	238	20.00	
3000			3500			4000			4500			
<i>Delta T</i>	<i>GPM</i>	<i>Ft. Hd.</i>	<i>Delta T</i>	<i>GPM</i>	<i>Ft. Hd.</i>	<i>Delta T</i>	<i>GPM</i>	<i>Ft. Hd.</i>	<i>Delta T</i>	<i>GPM</i>	<i>Ft. Hd.</i>	
100F	57	1.15	100F	67	0.42	100F	76	0.42	100F	86	0.42	
90F	63	1.42	90F	74	0.50	90F	84	0.58	90F	75	0.50	
80F	71	1.79	80F	83	0.67	80F	95	0.92	80F	107	0.58	
70F	81	2.34	70F	95	0.92	70F	109	1.17	70F	122	0.67	
60F	95	3.19	60F	111	1.17	60F	127	1.42	60F	143	0.92	
50F	114	4.59	50F	133	1.50	50F	152	2.42	50F	171	2.92	
45F	127	5.67	45F	148	2.08	45F	169	2.58	45F	190	4.17	
40F	143	7.18	40F	166	2.60	40F	190	3.17	40F	214	6.25	
35F	163	9.27	35F	190	3.33	35F	217	4.42	35F	244	8.17	
30F	190	12.76	30F	222	4.58	30F	253	6.08	30F	285	11.17	
25F	228	18.37	25F	266	7.33	25F	304	9.67	25F	342	16.08	
20F	285	28.70	20F	333	11.33	20F	380	15.17	20F	428	25.17	
5000			5500			6000						
<i>Delta T</i>	<i>GPM</i>	<i>Ft. Hd.</i>	<i>Delta T</i>	<i>GPM</i>	<i>Ft. Hd.</i>	<i>Delta T</i>	<i>GPM</i>	<i>Ft. Hd.</i>				
100F	95	0.50	100F	105	0.58	100F	114	0.67				
90F	106	0.58	90F	116	0.67	90F	127	0.75				
80F	119	0.67	80F	131	0.92	80F	143	0.92				
70F	136	0.83	70F	149	1.25	70F	163	2.50				
60F	158	2.08	60F	174	2.92	60F	190	4.17				
50F	190	4.17	50F	209	5.83	50F	228	6.00				
45F	211	6.25	45F	232	7.25	45F	253	7.42				
40F	238	7.92	40F	261	9.25	40F	285	9.42				
35F	271	10.42	35F	299	12.08	35F	326	12.33				
30F	317	14.25	30F	348	16.50	30F	380	16.83				
25F	380	21.42	25F	418	23.83	25F	456	24.25				
20F	475	33.50	20F	523	37.25	20F	570	37.92				

Appendix G: Wiring Diagrams

Note: Wiring diagrams are for reference only, please refer to the wiring shipped with the boiler for accuracy

Figure 30: 1000 Wiring Diagram

Page 1-A

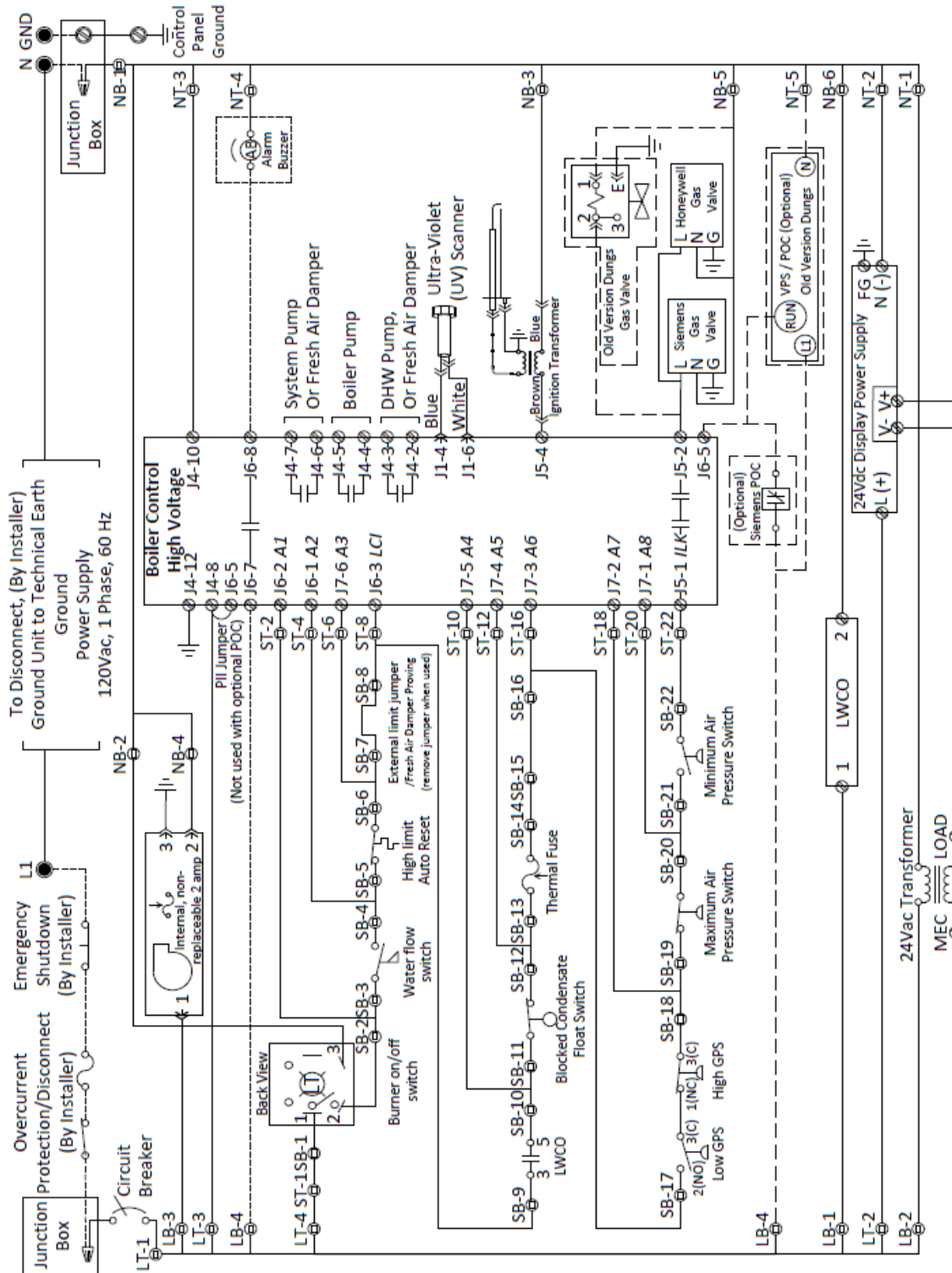

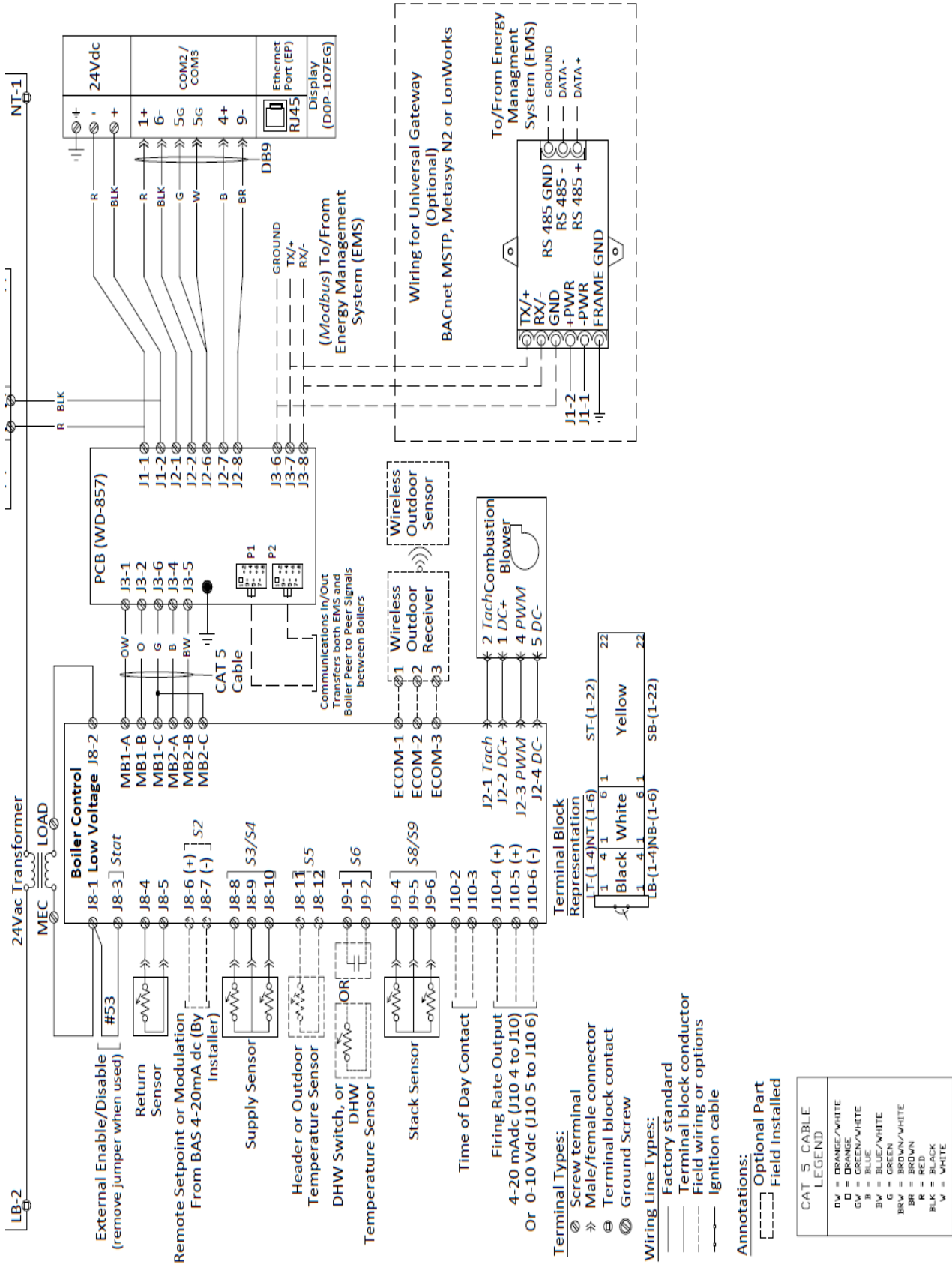
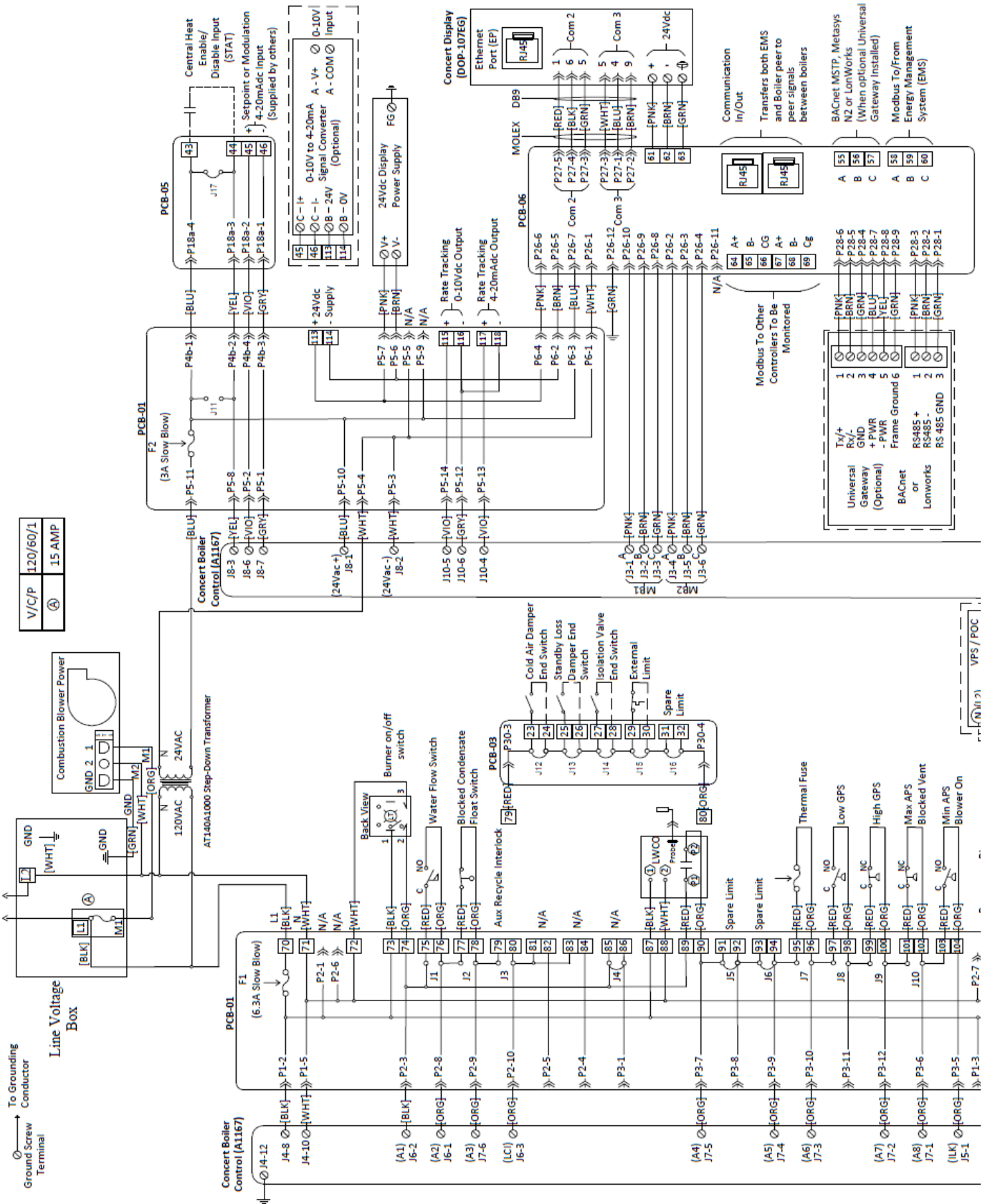

Figure 31: 1500 To 3000 115 VAC Single Phase Wiring Diagram

Note: Wiring diagrams are for reference only, please refer to the wiring shipped with the boiler for accuracy

Boiler must be grounded in accordance with ANSI National Electric Code.
 Connect to V/C/P Power Supply
 IMPORTANT: The wiring shown for devices supplied and installed by others is suggested only. Certification of, and responsibility for the correctness of the wiring is the responsibility of the supplier of these devices. Bryan Steam LLC accepts no responsibility for the correctness or safety or execution of this wiring or of the operation of such devices.



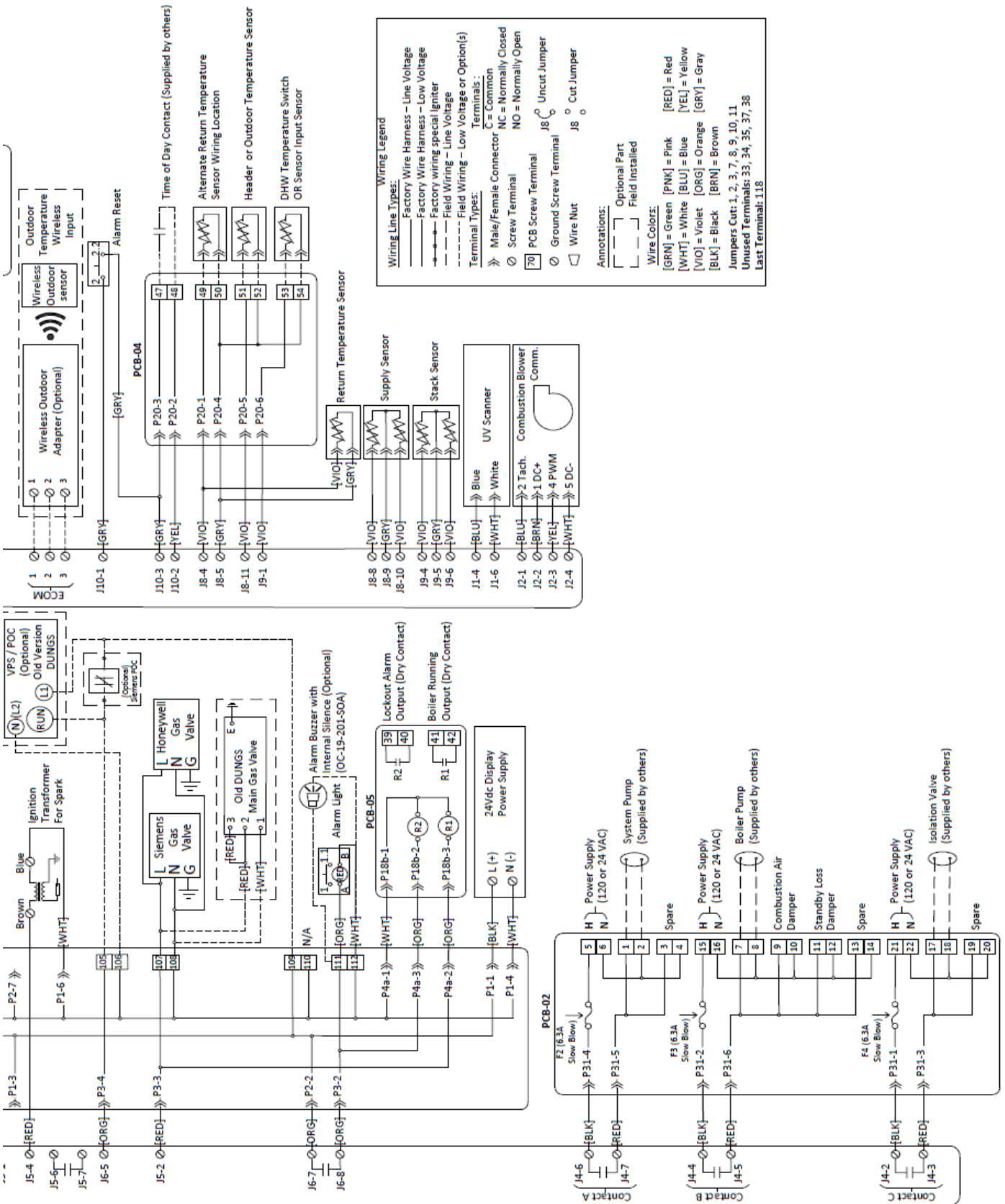
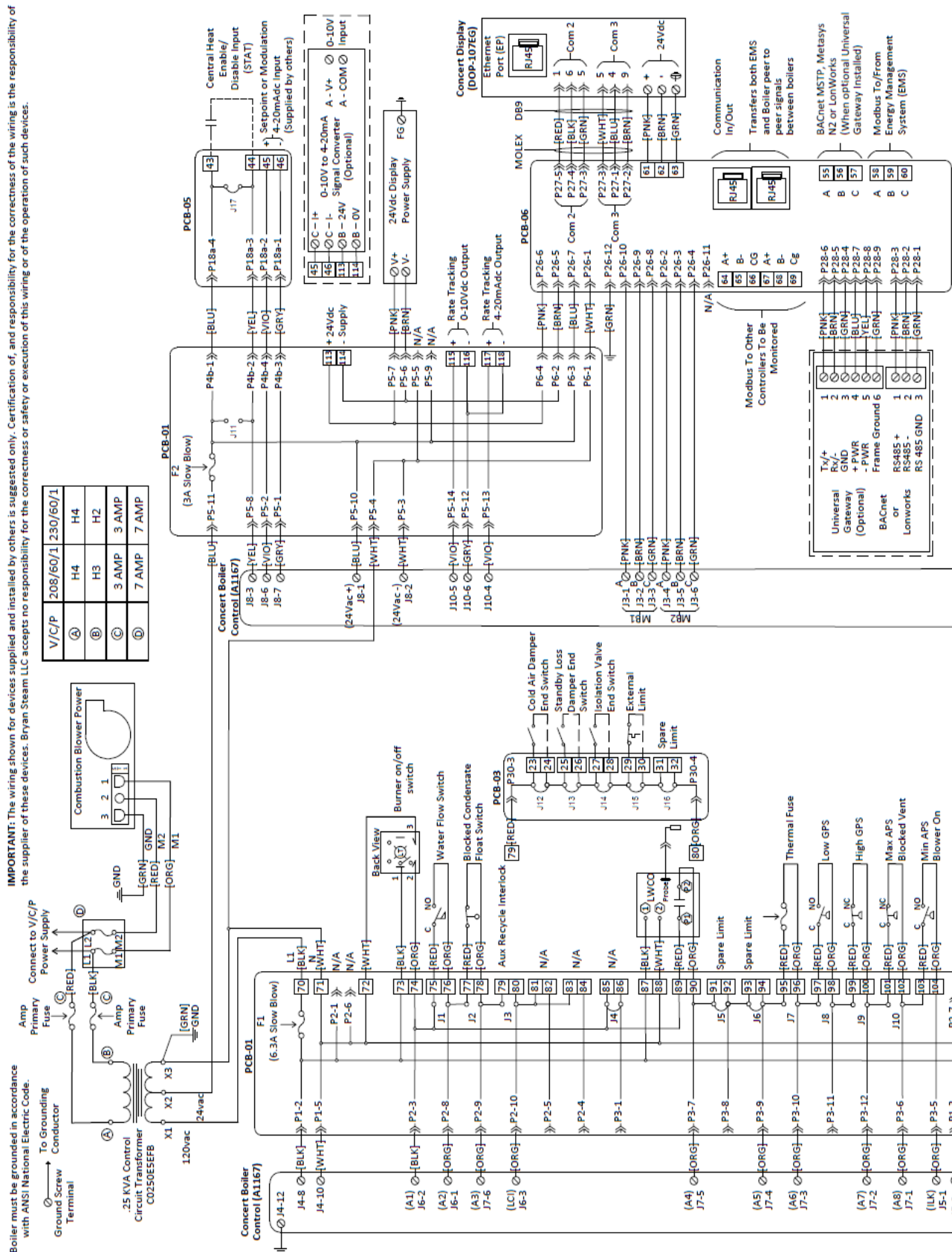

Figure 32: 1500 To 3000 208 – 230 VAC Single Phase Wiring Diagram

Note: Wiring diagrams are for reference only, please refer to the wiring shipped with the boiler for accuracy

Page 1-A



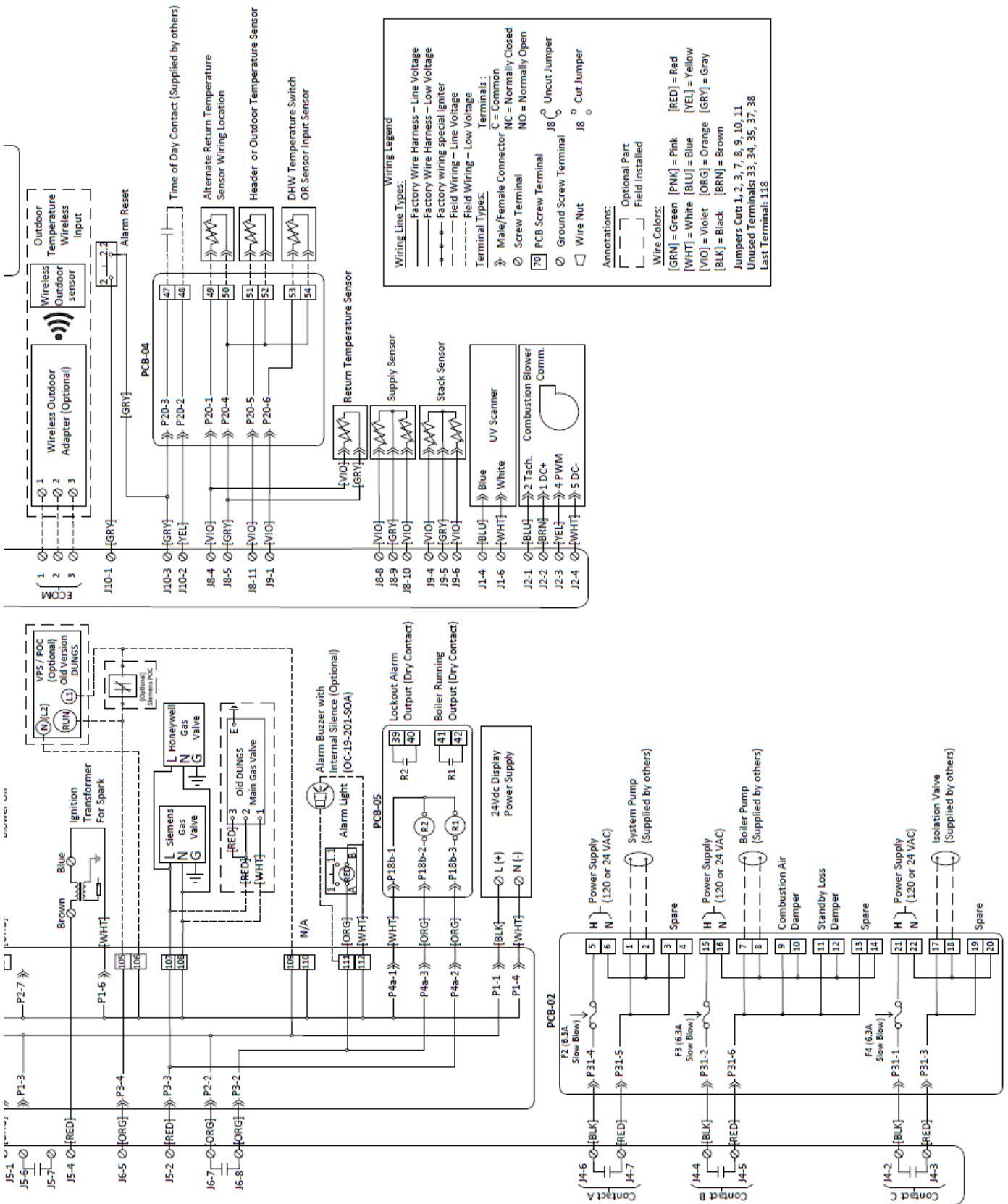
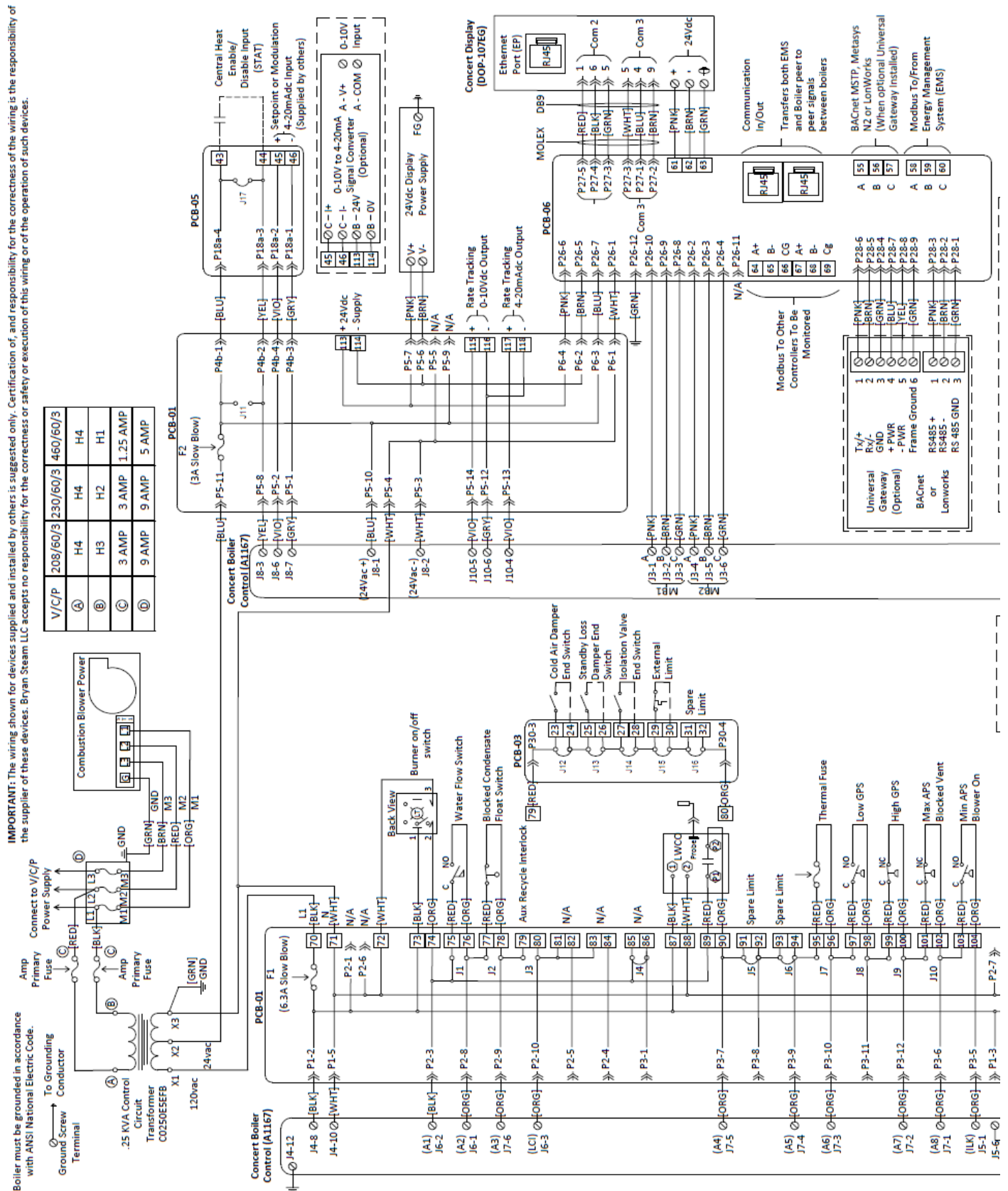
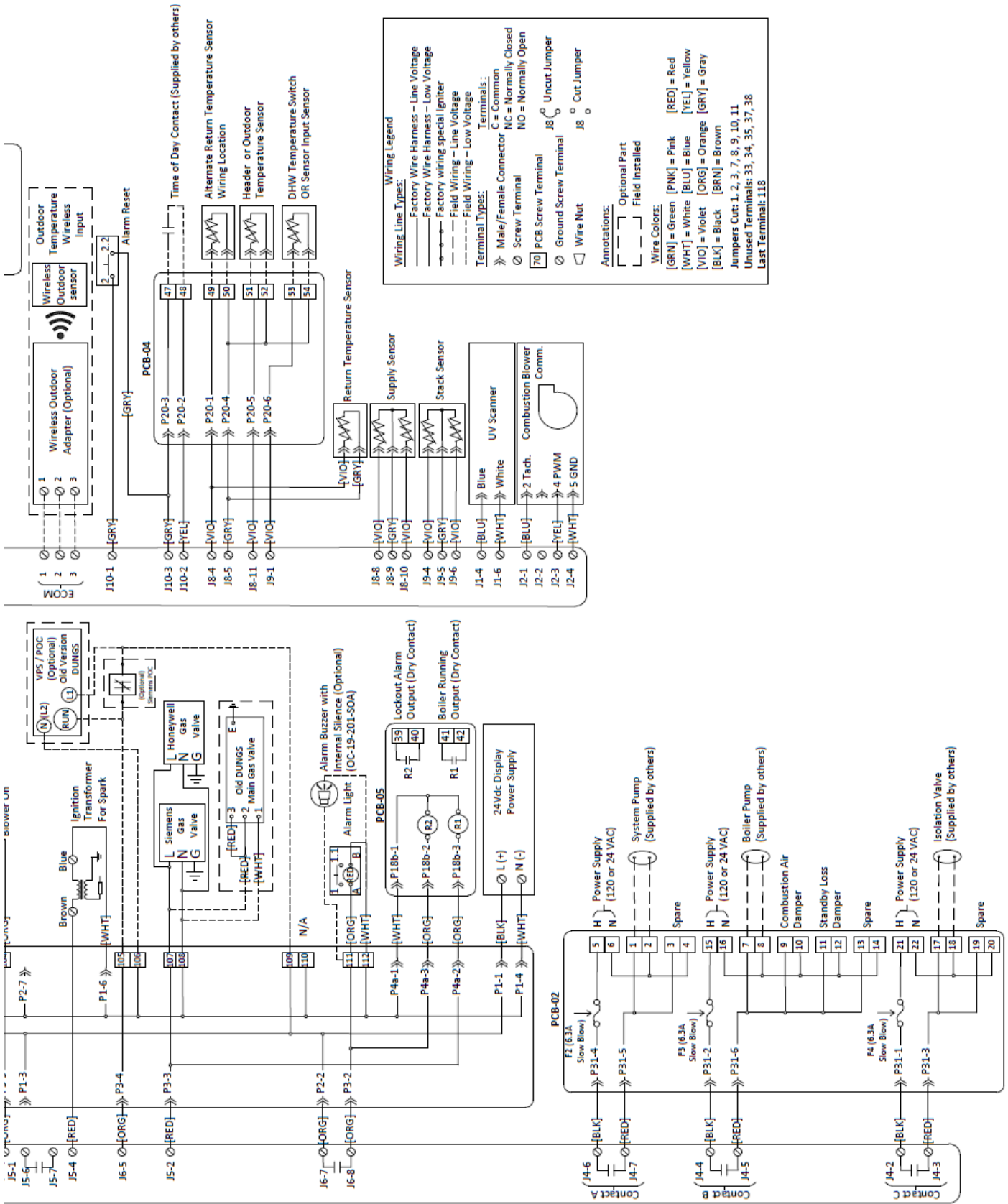

Figure 33: 2000 To 3000 208-460 VAC Three Phase Wiring Diagram

Note: Wiring diagrams are for reference only, please refer to the wiring shipped with the boiler for accuracy

Page 1-A





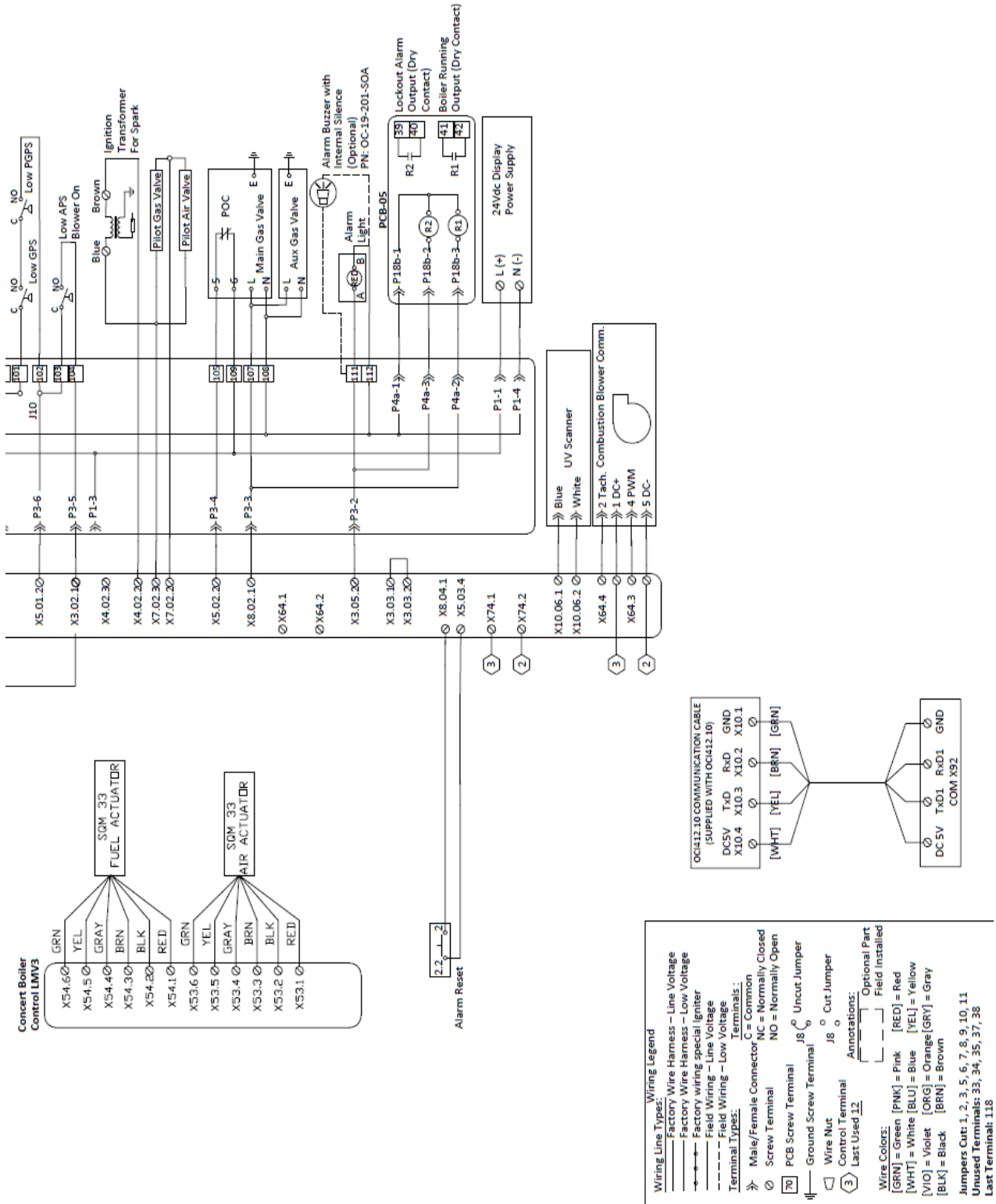

Wiring Legend

Wiring Line Types:
 - Factory Wire Harness - Line Voltage
 - Factory Wire Harness - Low Voltage
 - Factory wiring special igniter
 - Field Wiring - Line Voltage
 - Field Wiring - Low Voltage

Terminal Types:
 - Male/Female Connector C = Common
 - Screw Terminal NC = Normally Closed
 - NO = Normally Open

Terminal Symbols:
 [70] PCB Screw Terminal J8 (C) Uncut Jumper
 [71] Ground Screw Terminal J8 (C) Cut Jumper
 [72] Wire Nut J8 (C) Cut Jumper
 [73] Control Terminal
 [74] Last Used

Annotations:
 [75] Optional Part
 [76] Field Installed

Wire Colors:
 [GRN] = Green [PNK] = Pink [RED] = Red
 [WHT] = White [BLU] = Blue [YEL] = Yellow
 [VIO] = Violet [ORG] = Orange [GRY] = Gray
 [BLK] = Black [BRN] = Brown

Jumpers Cut: 1, 2, 3, 5, 6, 7, 8, 9, 10, 11
Unused Terminals: 33, 34, 35, 37, 38
Last Terminal: 118

IMPORTANT: The wiring shown for devices supplied and installed by others is suggested only. Certification of, and responsibility for the correctness of the wiring is the responsibility of the supplier of these devices. Bryan Steam LLC accepts no responsibility for the correctness or safety of execution of this wiring or of the operation of such devices.

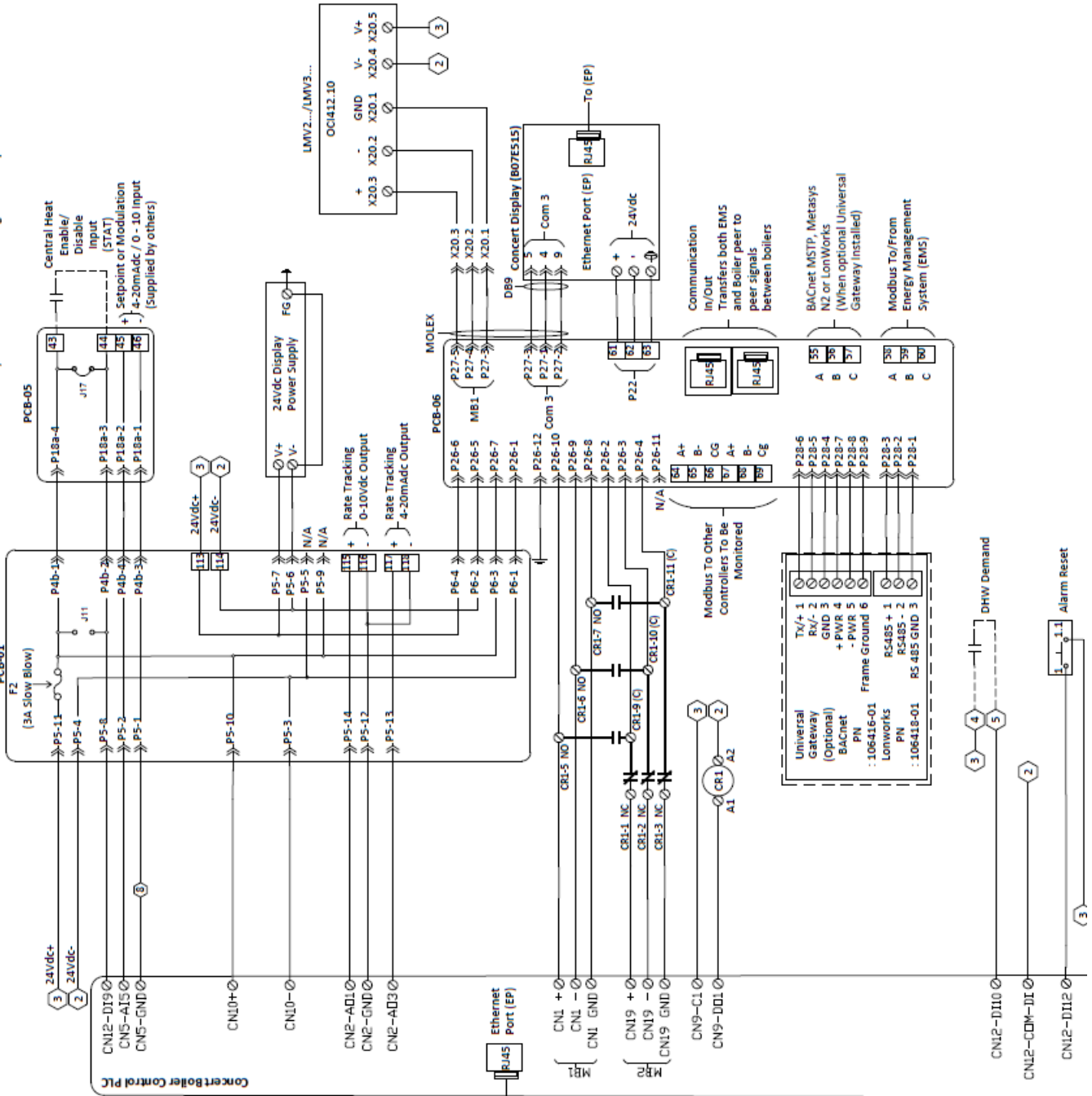

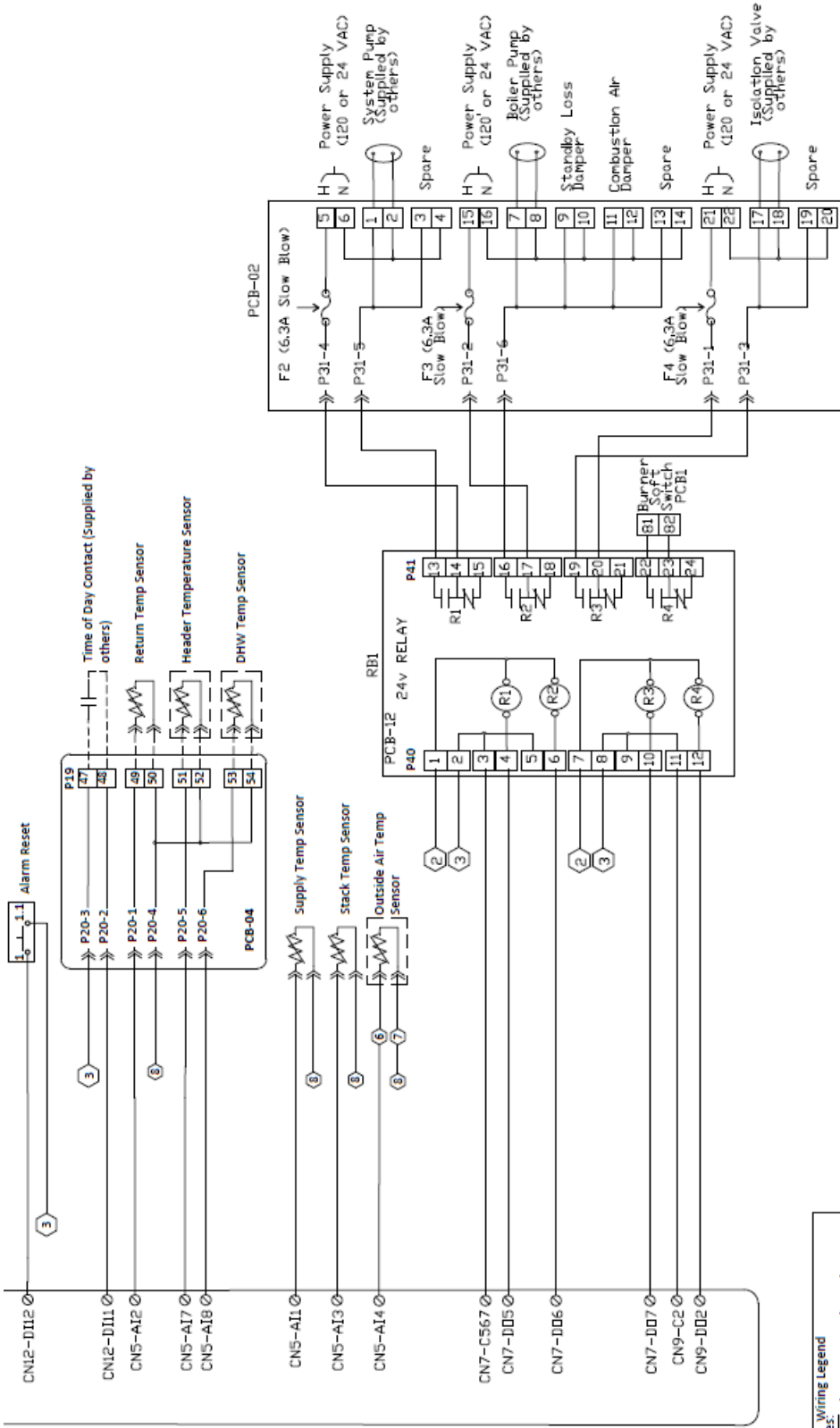

Wiring Legend

——— Factory Wire Harness – Line Voltage
 ——— Factory Wire Harness – Low Voltage
 - - - - - Field wiring special igniter
 - - - - - Field Wiring – Line Voltage
 Field Wiring – Low Voltage
Terminal Types:
 ⤵ Male/Female Connector C = Common
 ⦿ Screw Terminal
 ⦿ PCB Screw Terminal
 ⊥ Ground Screw Terminal
 □ Wire Nut
 □ Control Terminal
 Ⓟ Last Used 12
 Ⓟ Optional Part
 [] Field Installed
Wire Colors:
 [GRN] = Green [PNK] = Pink [RED] = Red
 [WHT] = White [BLU] = Blue [YEL] = Yellow
 [VIO] = Violet [ORG] = Orange [GRY] = Gray
 [BLK] = Black [BRN] = Brown

Jumpers Cut: 1, 2, 3, 5, 6, 7, 8, 9, 10, 11
 Unused Terminals: 33, 34, 35, 37, 38
 Last Terminal: 118

Appendix H: Default Modulation and Lightoff Rates

Parameter	Model				
	1000	1500	2000	2500	3000
Max Input Rate (MBH)	999	1500	1999	2500	3000
CH/DHW Max. Modulation Rate (RPM)	5650	4500	4000	4100	4300
Minimum Modulation Rate (RPM)	1200	1400	1300	900	1050
Light-off (RPM)	1300	1800	1800	1800	1600
Maximum Light-off (RPM)	1800	2000	2000	2000	2000
Minimum Light-off (RPM)	1100	900	900	900	900

Appendix I: Factory (seller) Limited Warranty

LIFETIME THERMAL SHOCK WARRANTY

Subject to the terms and conditions herein, Seller warrants to the original owner at the original installation site that the boiler pressure vessel is covered against failure due to "Thermal Shock" for the lifetime of the boiler as described below:

- This warranty is only valid if the boiler is installed and operated in accordance with our Installation and Operation Manual.
- This warranty shall cover leaks in pressure vessel (*boiler tubes, upper and lower drums*) when upon inspection by seller, such damage is attributed to unequal expansion, often described as "thermal shock."
- This warranty does not cover damages or failures that can be attributed to corrosion, scale, dirt or sludge accumulation in the boiler, low water conditions, failure of any safety devices or any other improper service, operation or neglect.

LIFETIME PRESSURE VESSEL WARRANTY

Subject to the terms and conditions herein, Seller warrants to the original owner at the original installation site that the boiler pressure vessel is covered against leaks (*boiler tubes, upper and lower drums*) for the lifetime of the boiler as described below:

- This warranty is only valid if the boiler is installed and operated in accordance with our Installation and Operation Manual.
- This warranty shall cover leaks in pressure vessel (as described above) when upon inspection by seller, such damage is attributed to unequal expansion, often described as "thermal shock."
- This warranty does not cover damages or failures that can be attributed to corrosion, scale, dirt or sludge accumulation in the boiler, low water conditions, failure of any safety devices or any other improper service, operation or neglect.

Subject to the terms and conditions herein, Seller warrants to the original owner at the original installation site that the pressure vessel and flue collector are covered against failure due to fireside flue gas corrosion per the schedule as follows:

- Upper and Lower Pressure Vessel Headers: 10 years from date of shipment.
- Flexible Boiler Tubes: 5 years from date of shipment.
- Flue Collector Sides, Top and Bottom: 5 years from date of shipment.

BURNER HEAD WARRANTY

Subject to the terms and conditions herein, Seller warrants to the original owner at the original installation site that the burner head will be free from defects in materials and workmanship for a period of one year after the date of shipment.

LIMITED WARRANTY

Subject to the terms and conditions herein, Seller warrants to the original owner at the original installation site those products manufactured by Seller ("Products") comply, at the time of manufacture, with recognized hydronics industry regulatory agency standards and requirements then in effect and will be free from defects in materials and workmanship for a period of one year after the date of shipment.

REMEDY

- A. The sole remedy for breach of this warranty is expressly limited to the repair or replacement of any part found to be defective under conditions of normal use within the Warranty Period. Labor for removal and /or installation is not included.
- B. Warranty – The owner must notify the original installer of the Product and Seller (*Attention: Bryan Steam, P.O. Box 3244, Lancaster, PA 17604-3244*), in writing, within the Warranty Period, providing a detailed description of all claimed defects. Transportation to a factory or other designated facility for repairs of any products or items alleged defective shall, in all events, be the responsibility and at the cost of the owner.

EXCLUSIONS

Seller shall have no liability for and this warranty does not cover:

- A. Incidental, special or consequential damages, such as loss of the

use of products, facilities or production, inconvenience, loss of time or labor expense involved in repairing or replacing the alleged defective Product.

- B. The performance of any Product under conditions varying materially from those under which such Product is usually tested under industry standards as of the time of shipment
- C. Any damage to the Product due to abrasion, erosion, corrosion, deterioration, abnormal temperatures or the influence of foreign matter or energy.
- D. The design or operation of owner's plant or equipment or of any facility or system of which any Product may be made a part.
- E. The suitability of any Product for any particular application.
- F. Any failure resulting from misuse, modification not authorized by Seller in writing, improper installation or lack of or improper maintenance.
- G. Equipment furnished by the owner, either mounted or un-mounted, or when contracted for by the owner to be installed or handled.
- H. Leakage or other malfunction caused by:
 1. Defective installations in general and specifically, any installation, which is made:
 - a. In violation of applicable state or local plumbing housing or building codes,
 - b. Without a certified ASME, pressure relief valve, or
 - c. Contrary to the written instructions furnished with the unit.
 2. Adverse local conditions in general and, specifically, sediment or lime precipitation in the tubes and/or headers or corrosive elements in the atmosphere.
 3. Misuse in general and, specifically, operation and maintenance contrary to the written instructions furnished with the unit, disconnection, alteration or addition of components or apparatus, not approved by Seller, operation with fuels or settings other than those set forth on the rating plate or accidental or exterior damage.
- I. Production of noise, orders, discoloration or rusty water.
- J. Damage to surrounding area or property caused by leakage or malfunction.
- K. Costs associated with the replacement and/or repair of the unit including: any freight, shipping or delivery charges, and removal, installation or reinstallation charges, any material and/or permits required for installation, reinstallation or repair, charges to return the boiler and or components.

Seller's liability under this warranty shall not in any case exceed the amount paid for the Product found to be defective.

THIRD-PARTY WARRANTIES

For goods or components not manufactured by Seller, the warranty obligations of Seller shall, in all respects, conform and be limited to one year from the date of shipment.

SEVERABILITY

To the extent that any provisions shall of this warranty would be void or prohibited under applicable law, such provisions shall be limited in effect to the minimum extent necessary to render the remaining provisions hereof enforceable.

Appendix J: Start-up Form

Note: Digital start-up forms can be found on company website.

CONDENSING BOILER START-UP FORM

(REFER TO THE PRODUCT MANUAL FOR QUESTIONS REGARDING THE INSTALLATION AND OPERATION OF THIS PRODUCT)

JOB NAME: _____ **MODEL #:** _____
ADDRESS: _____ **SERIAL #:** _____
CITY: _____ **ST:** _____ **ZIP:** _____ **DATE:** _____

GAS SUPPLY: Natural Gas Static Pressure (Unit Off): _____ "wc Gas Pipe Diameter: _____ " (inches)
 LP Gas Dynamic Pressure (100% Fire): _____ "wc
 Is there an inlet gas lockup regulator on the supply? Yes No
 If **Yes**, is it ten feet upstream from the appliance? Yes No, explain: _____

COMBUSTION:

<p><u>High Fire:</u> O₂: _____ % CO₂: _____ % CO: _____ ppm Excess Air: _____ % Stack Temperature: _____ °F</p>	<p><u>Low Fire:</u> O₂: _____ % CO₂: _____ % CO: _____ ppm Excess Air: _____ % Stack Temperature: _____ °F</p>
--	---

WATER: Supply Temperature: _____ °F Return Temperature: _____ °F Delta T _____ °F

ELECTRICAL: Supply Voltage: _____ Total Amp Draw: _____

VENTING & AIR INTAKE:

<p><u>Vent:</u> Material: _____ Diameter: _____ "</p>	<p><u>Combustion Air:</u> Material: _____ Diameter: _____ "</p>
---	---

<table border="0"> <tr> <td>90° SR Elbow: _____ Qty</td> <td>ft / ea</td> <td>Sub-Total</td> <td>_____ ft</td> </tr> <tr> <td>90° LS Elbow: _____ Qty</td> <td>ft / ea</td> <td>_____ ft</td> <td></td> </tr> <tr> <td>45° Elbow: _____ Qty</td> <td>ft / ea</td> <td>_____ ft</td> <td></td> </tr> <tr> <td>Horizontal Straight: _____ Lgth</td> <td>1 ft / 1ft</td> <td>_____ ft</td> <td></td> </tr> <tr> <td>Vertical Straight: _____ Lgth</td> <td>1 ft / 1ft</td> <td>_____ ft</td> <td></td> </tr> <tr> <td colspan="2">Total Equiv. Length:</td> <td style="background-color: #f4a460;">_____</td> <td>ft</td> </tr> </table>	90° SR Elbow: _____ Qty	ft / ea	Sub-Total	_____ ft	90° LS Elbow: _____ Qty	ft / ea	_____ ft		45° Elbow: _____ Qty	ft / ea	_____ ft		Horizontal Straight: _____ Lgth	1 ft / 1ft	_____ ft		Vertical Straight: _____ Lgth	1 ft / 1ft	_____ ft		Total Equiv. Length:		_____	ft	<table border="0"> <tr> <td>90° SR Elbow: _____ Qty</td> <td>ft / ea</td> <td>Sub-Total</td> <td>_____ ft</td> </tr> <tr> <td>90° LS Elbow: _____ Qty</td> <td>ft / ea</td> <td>_____ ft</td> <td></td> </tr> <tr> <td>45° Elbow: _____ Qty</td> <td>ft / ea</td> <td>_____ ft</td> <td></td> </tr> <tr> <td>Horizontal Straight: _____ Lgth</td> <td>1 ft / 1ft</td> <td>_____ ft</td> <td></td> </tr> <tr> <td>Vertical Straight: _____ Lgth</td> <td>1 ft / 1ft</td> <td>_____ ft</td> <td></td> </tr> <tr> <td colspan="2">Total Equiv. Length:</td> <td style="background-color: #f4a460;">_____</td> <td>ft</td> </tr> </table>	90° SR Elbow: _____ Qty	ft / ea	Sub-Total	_____ ft	90° LS Elbow: _____ Qty	ft / ea	_____ ft		45° Elbow: _____ Qty	ft / ea	_____ ft		Horizontal Straight: _____ Lgth	1 ft / 1ft	_____ ft		Vertical Straight: _____ Lgth	1 ft / 1ft	_____ ft		Total Equiv. Length:		_____	ft
90° SR Elbow: _____ Qty	ft / ea	Sub-Total	_____ ft																																														
90° LS Elbow: _____ Qty	ft / ea	_____ ft																																															
45° Elbow: _____ Qty	ft / ea	_____ ft																																															
Horizontal Straight: _____ Lgth	1 ft / 1ft	_____ ft																																															
Vertical Straight: _____ Lgth	1 ft / 1ft	_____ ft																																															
Total Equiv. Length:		_____	ft																																														
90° SR Elbow: _____ Qty	ft / ea	Sub-Total	_____ ft																																														
90° LS Elbow: _____ Qty	ft / ea	_____ ft																																															
45° Elbow: _____ Qty	ft / ea	_____ ft																																															
Horizontal Straight: _____ Lgth	1 ft / 1ft	_____ ft																																															
Vertical Straight: _____ Lgth	1 ft / 1ft	_____ ft																																															
Total Equiv. Length:		_____	ft																																														

* SR - Short Radius / LS - Long Sweep/Sanitary Elbow

Notes (Refer to O&M Manual):
 1. Make sure total equiv. length does not exceed max equiv. length shown in Manual.
 2. Vent and combustion air terminals do not count towards total equivalent length.
 3. Pressure drop for flexible polypropylene liner is 20% greater than for rigid pipe. Multiply measured flexible polypropylene line length by 1.2 to obtain equivalent length.
 4. Max equivalent length of flexible polypropylene liner is 48 ft.
 5. All elbows referenced are short radius.

Vent / Air Termination:

Vertical Vent w/ Room Air Vertical Direct Vent
 Horizontal Vent w/ Room Air Horizontal Direct Vent
 Vertical Vent w/ Sidewall Air

CLEARANCES: Front: _____ Left Side: _____ Top: _____
 Rear: _____ Right Side: _____

NOTES / COMMENTS: _____

<p>START-UP PERFORMED BY:</p> COMPANY: _____ ADDRESS: _____ CITY: _____ ST: _____ ZIP: _____ NAME: _____ PHONE: _____	<p>START-UP APPROVED BY:</p> COMPANY: _____ ADDRESS: _____ CITY: _____ ST: _____ ZIP: _____ NAME: _____ PHONE: _____
---	--



Bryan Steam

783 N. Chili Ave, Peru, IN 46970

Phone: 765-473-6651

www.bryanboilers.com