

# **BRYAN STEAM**

## **Vertical Tray Type Boiler Feedwater Deaerators** **Capacities 5,000 to 60,000 PPH (145 to 1740 BHP)**



5,000 PPH unit  
shown

The Bryan tray type deaerator is unsurpassed in performance and reliability. These units are ASME Code pressurized units, and are guaranteed to deliver deaerated water at a maximum oxygen content of .005cc/l (7PPB) and zero measurable CO<sub>2</sub>. All internal surfaces that come in contact with undeaerated water are constructed of type 304L stainless steel for long life and low maintenance. Their long residence time makes them readily adaptable to all systems, even where wide load swings occur.

A complete line of boiler feedpump and control packages is available making the Bryan tray deaerator a completely packaged unit ready for installation with the minimum amount of field assembly.

### **Performance Features**

- Oxygen removal to .005 cc/l (7 PPB)
- CO<sub>2</sub> removal to 0% measurable
- Reduce chemical costs
- Reduce boiler and system corrosion
- Improve boiler efficiency
- Pre-heat boiler feedwater
- Quick equipment payback, compared to chemical oxygen removal

### **Construction Features**

- Constructed to ASME Section VIII, Division I for 50 PSIG
- Hinged tray access door
- Standard 10 minutes deaerated water storage
- All internal surfaces that contact undeaerated water are constructed of type 304L stainless steel
- Internal direct contact vent condenser for minimum steam loss
- Structural steel stand/pump platform
- 2-stage deaeration
- Available as completely packaged unit including pumps and control panel

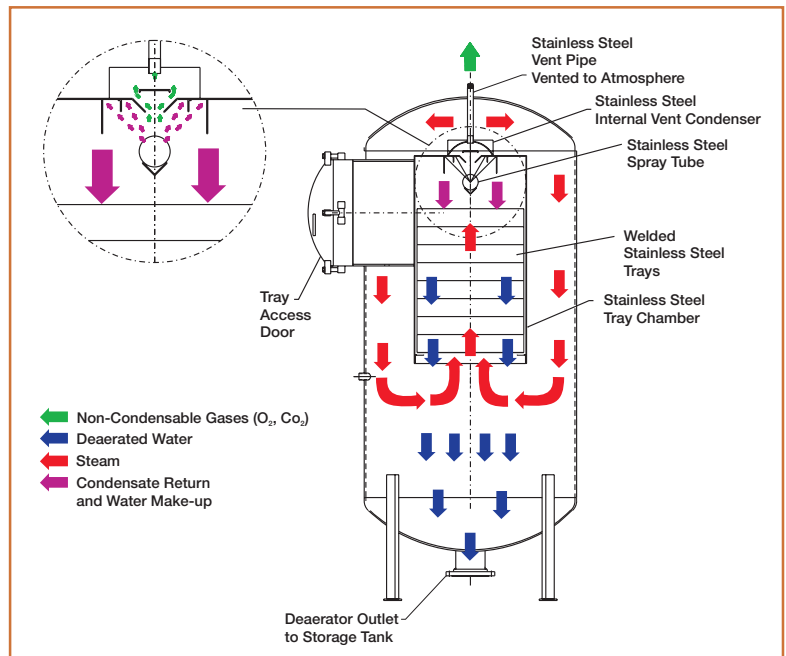

# Bryan Vertical Tank Tray Type Deaerators

1. High water level control
2. Low water level control
3. Make-up water control
4. Vacuum breaker
5. Temperature gauge
6. Pressure gauge
7. Overflow trap
8. Vent
9. Pump suction
10. Pump bypass
11. Chemical port
12. Drain
13. Sample port
14. High temperature condensate return
15. Gauge glass
16. Tray access door

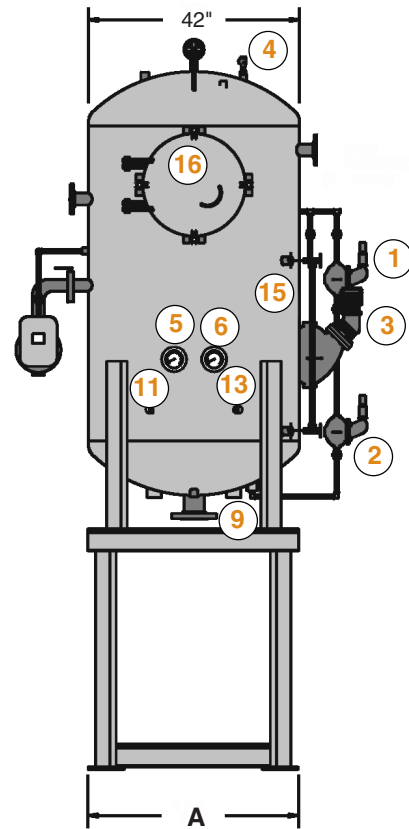
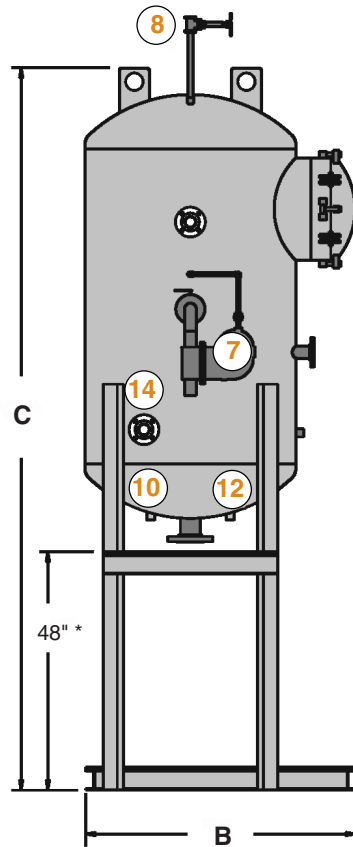

\*Note: Stand height shown is standard. Total height varies depending upon pump specifications and job conditions. Dimensions are for reference only and may change without notice. Consult factory for certified dimensions.

## Specifications

Model	Capacity			Dimensions in inches (cm)			
	Pounds/hr (kg/h)	Boiler hp (kW)	Storage in gallons (liters)	A Overall length	B Overall width	C Overall height	D Tank diameter
DTV-5	5,000 (2,268)	145 (1,422)	100 (378)	42 (107)	54 (137)	126 (320)	42 (107)
DTV-10	10,000 (4,536)	290 (2,844)	200 (757)	42 (107)	54 (137)	143 (363)	42 (107)
DTV-15	15,000 (6,804)	435 (4,267)	300 (1,136)	42 (107)	54 (137)	159 (404)	42 (107)
DTV-20	20,000 (9,072)	580 (5,689)	400 (1,514)	60 (152)	72 (183)	147 (313)	60 (152)
DTV-25	25,000 (11,340)	725 (7,111)	500 (1,893)	60 (152)	72 (183)	155 (394)	60 (152)
DTV-30	30,000 (13,608)	870 (8,533)	600 (2,271)	60 (152)	72 (183)	163 (414)	60 (152)
DTV-35	35,000 (15,876)	1,014 (9,956)	700 (2,650)	72 (183)	84 (213)	160 (406)	72 (183)
DTV-40	40,000 (18,144)	1,159 (11,378)	800 (3,028)	72 (183)	84 (213)	166 (422)	72 (183)
DTV-45	45,000 (20,412)	1,304 (12,800)	900 (3,407)	72 (183)	84 (213)	171 (434)	72 (183)
DTV-50	50,000 (22,680)	1,449 (14,222)	1,000 (3,785)	72 (183)	84 (213)	177 (450)	72 (183)
DTV-60	60,000 (27,216)	1,739 (17,067)	1,200 (4,542)	72 (183)	84 (213)	192 (488)	72 (183)



All tray assemblies in the Bryan tray deaerator are constructed of type 304L stainless steel. Bryan selects the most superior materials for all its deaerator applications.



**Bryan Steam — Leaders Since 1916**

783 N. Chili Ave., Peru, Indiana 46970 U.S.A.  
 Phone: 765-473-6651 • Internet: www.bryanboilers.com  
 Fax: 765-473-3074 • E-mail: bryanboilers@iquest.net