

Note: Entrance Tall Plates fit doors 1-3/4" to 2" thick.

WARNING: USE OF POWER DRIVER WILL STRIP SCREW HEADS

A

USE INCLUDED DOOR PREPARATION TEMPLATE FOR NON-PREPARED DOORS.

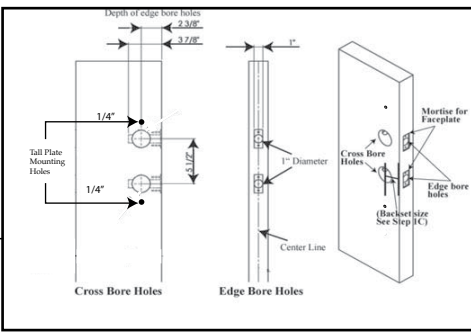

USE INCLUDED PLASTIC TEMPLATE TO LOCATE AND DRILL THE TWO TALL PLATE 1/4" MOUNTING HOLES. (See note on reverse side.)

B

Install deadbolt and entrance latches.

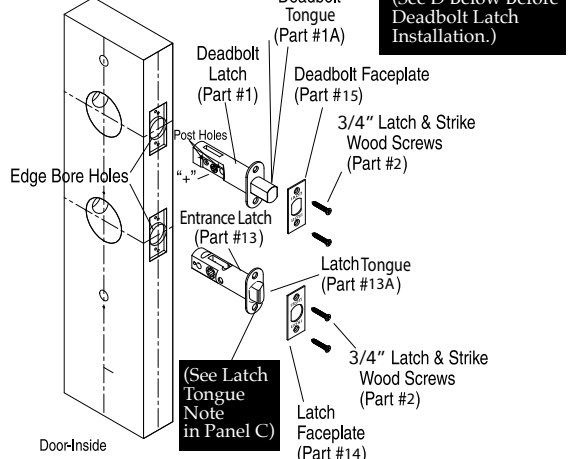

(See D Below Before Deadbolt Latch Installation.)

(See Latch Tongue Note in Panel C)

C Latch Tongue Note

Bevel side of latch tongue should contact curved end of face plate, and curved end of strike plate.

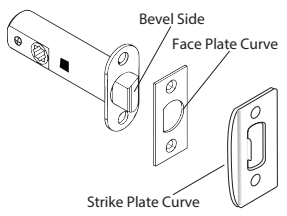

D Deadbolt Latch Tongue Note

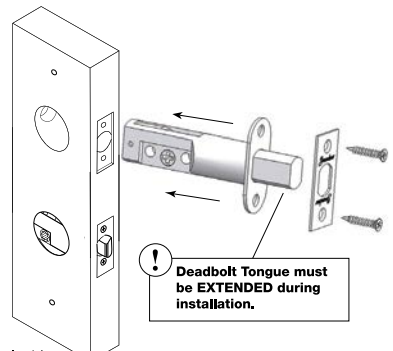

Door-Inside

Deadbolt Tongue must be EXTENDED during installation.

E

Intall screw extenders into exterior tall plate.

Tighten securely.

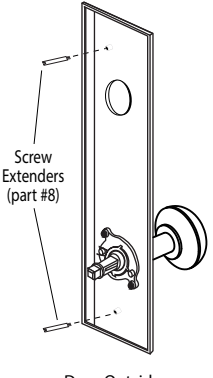

Door Outside

F Install cylinder into exterior tall plate.

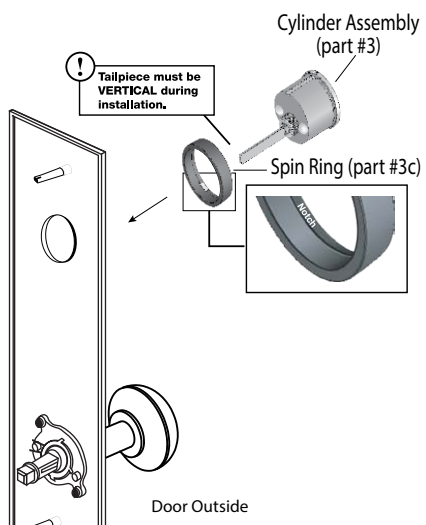

Door Outside

! Tallpiece must be VERTICAL during installation.

G

Place exterior tall plate on door outside.

Attach deadbolt adaptor plate with provided screws.

DO NOT FULLY TIGHTEN THESE SCREWS.

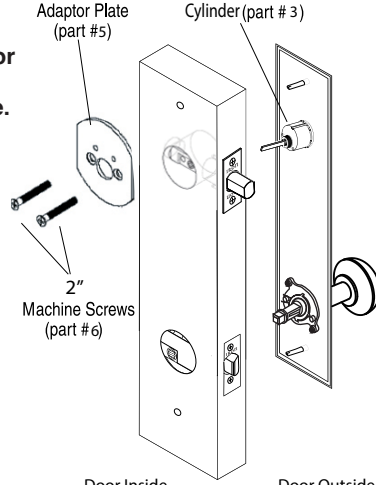

Door Inside

Door Outside

H

Slide exterior tall plate up, hold, and tighten deadbolt screws.

Check knob/lever operation. Latch tongue should retract and extend smoothly.

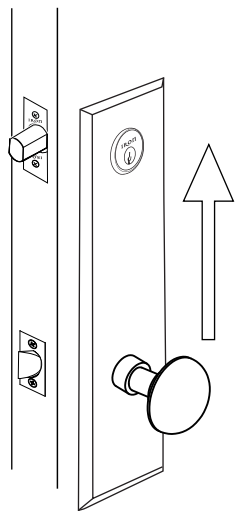

Door-Outside

I

Attach interior tall plate with included screws.

Check deadbolt operation by turning thumbturn and key.

Check knob/lever operation. Latch tongue should retract and extend smoothly.

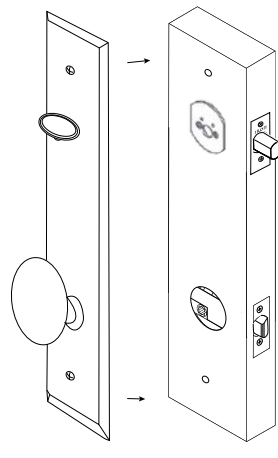

Door-Inside

J Install jamb strike plate.

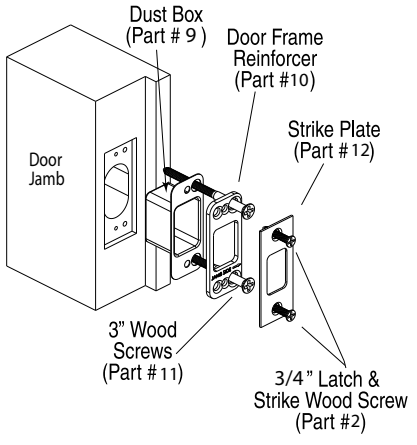

Door Jamb

Exploded Drawing for Tall Plate Entrance

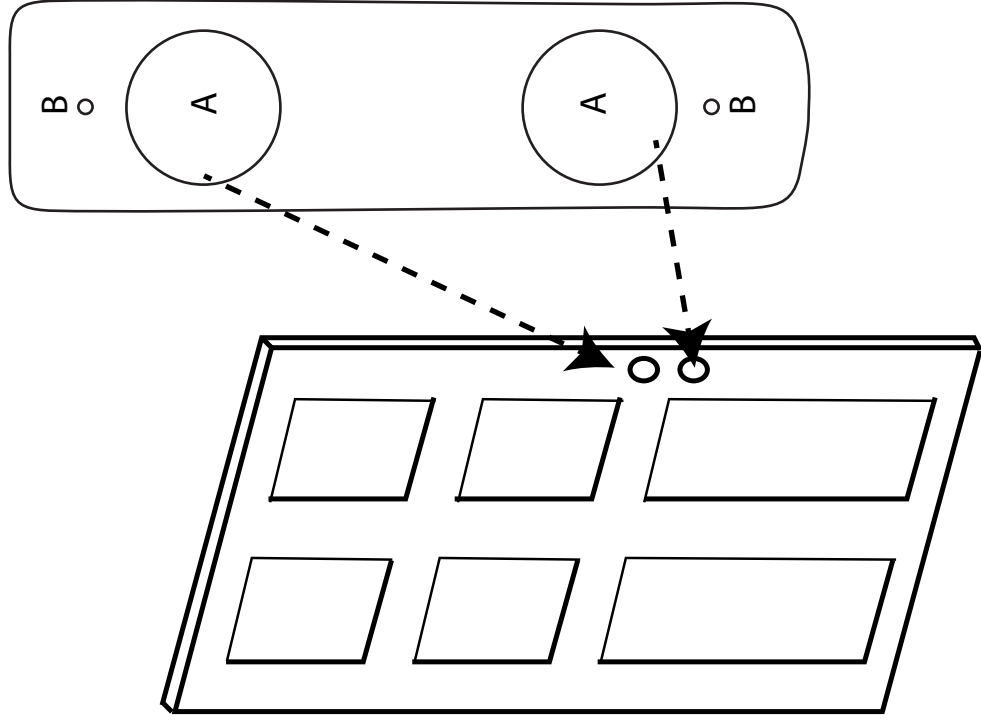

1. Push plastic template's large circles (A) into existing bore holes of door.
2. Use position of small holes (B) to mark and drill 1/4" holes through the door.

Part Number	Part Description
-------------	------------------

- | | |
|-----|---|
| 1. | Deadbolt Latch |
| 1A. | Latch Tongue |
| 2. | 3/4" Faceplate & Strike Wood Screws (8) |
| 3. | Cylinder Assembly |
| 3A. | Cylinder Body |
| 3B. | Tailpiece |
| 3C. | Spin Ring |
| 4. | Exterior Tall Plate & Knob/Lever Deadbolt Adapter Plate |
| 5. | 2" Machine Screws (2) for 1-3/4" thick doors. 2-1/4" Machine Screws (2) for 2" thick doors. |
| 6. | Thumbturn Assembly |
| 7. | 1-1/2" Oval Head Machine Screws (2) |
| 8. | Dustbox for Deadbolt |
| 9. | Door Frame Reinforcer |
| 10. | 3" Reinforcer Wood Screws (2) |
| 11. | Strike Plate for Deadbolt |
| 12. | Entrance Latch |
| 13. | 13A. Latch Tongue |
| 14. | Latch Faceplate |
| 15. | Deadbolt Faceplate |
| 16. | Handleset Spindle |
| 17. | Screw Extenders (2) |
| 18. | Interior Tall Plate & Knob/Lever |
| 19. | Strike Plate for Handleset |

