

Amphenol

© 2021 Amphenol Corporation

revision history				
rev	ecn no	description	dr	date
-	----	REFER TO SHEET 1/3	-	-

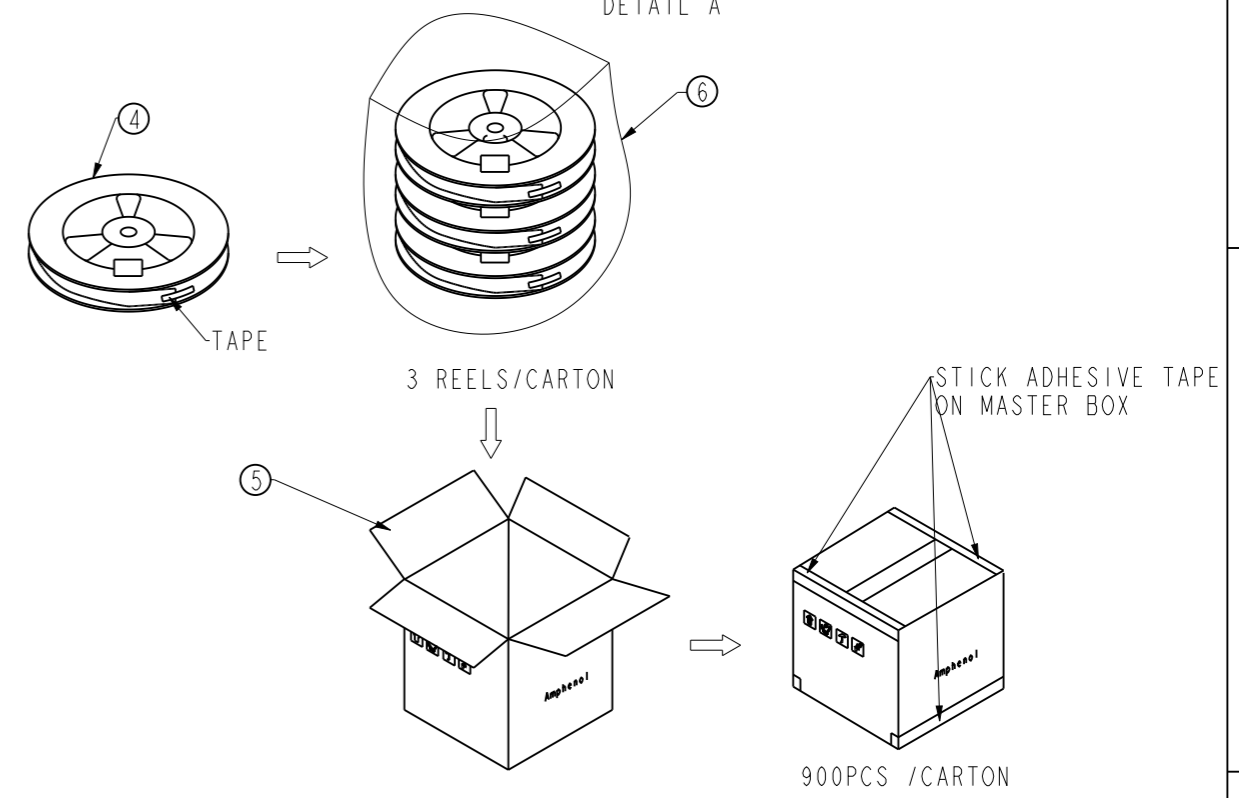
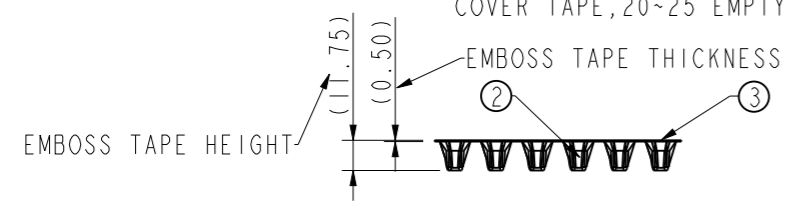
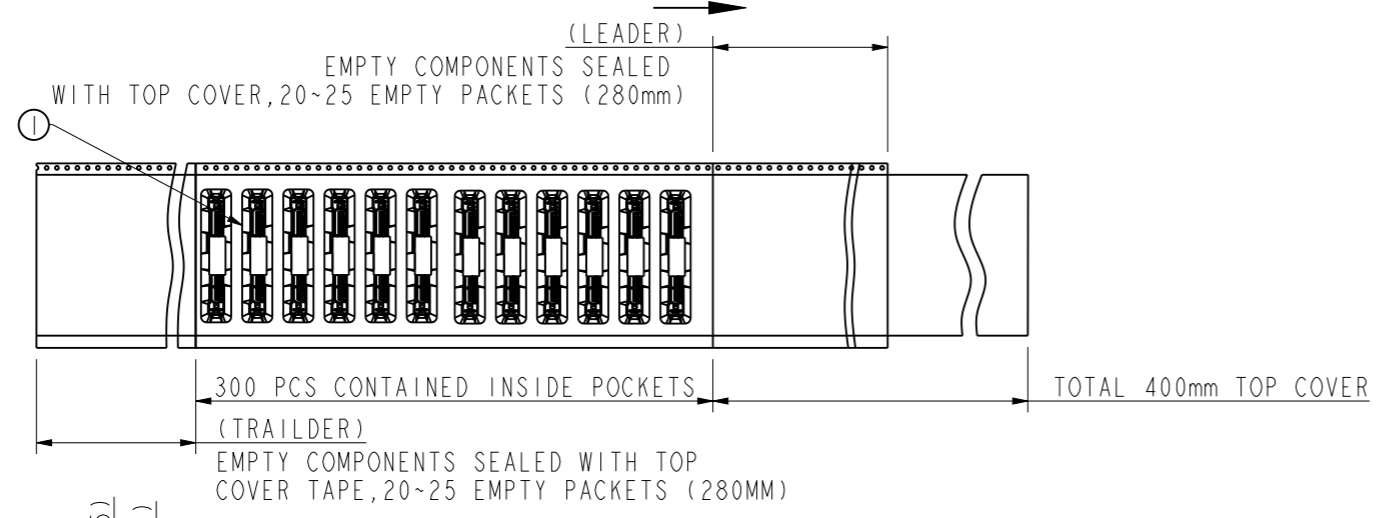
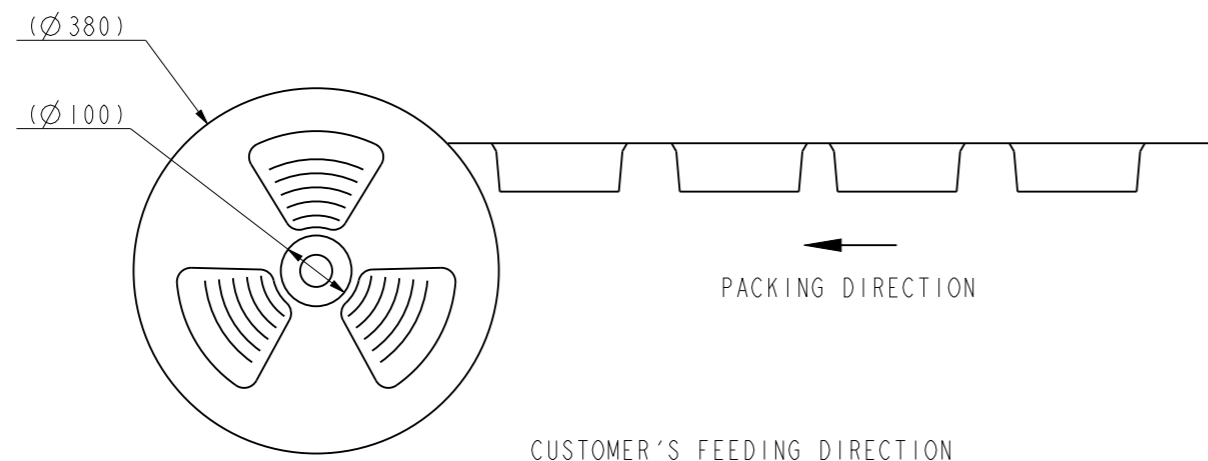
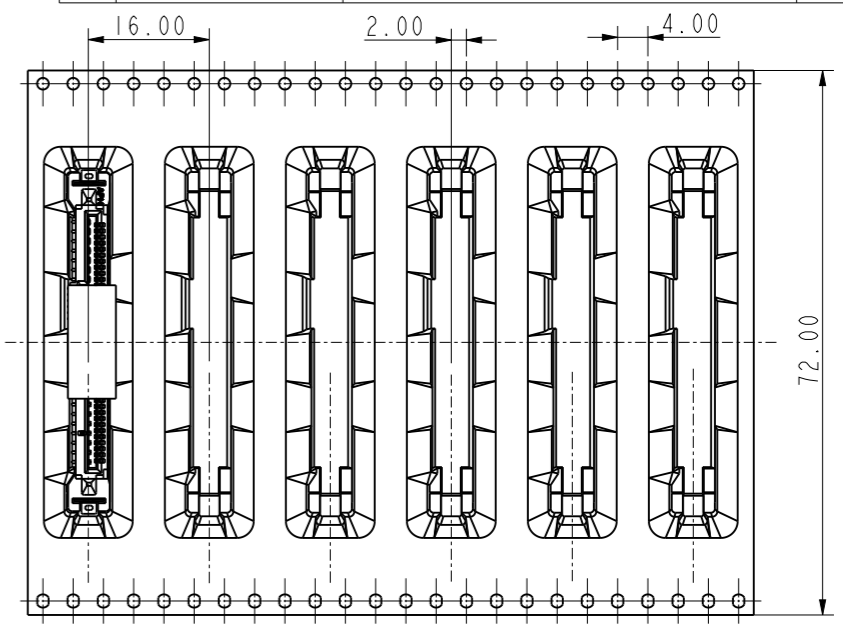
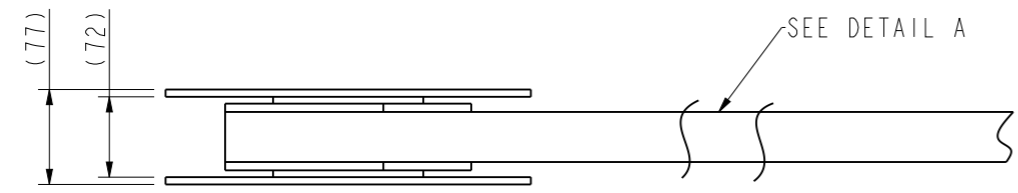

ITEM	DESCRIPTION	MATERIAL
6	PLASTIC BAG	NA
5	MASTER BOX	CORRUGATED FIBERBOARD
4	PP REEL	PP
3	TOP COVER TAPE	PET
2	EMBOSS TAPE	POLYSTYRENE
1	CONNECTOR	NA

spec ref	dr	Teng.Cao	Sep.21,2023
tolerance std	eng	Teng.Cao	Sep.21,2023
TOLERANCES UNLESS OTHERWISE SPECIFIED			
surface	linear	0.X	±0.50
		0.XX	±0.25
		0.XXX	±0.20
	angular	0°	±3°

		scale	2:1	size	A3
		ecn no	ELX-CD-FXXX-1		
amphenol-icc.com		rel level	RELEASE		
product family		PSAS	cat. no.	PSAS5F3I3016XXX	rev
					A2
					sheet 3 of 3