



INSTALLATION INSTRUCTIONS (61BA0010D) AIR CONDITIONING & HEAT PUMP INDOOR COILS

INTRODUCTION

Please note that HUD Manufactured Home Construction and Safety Standard Section 3280.714, paragraph (a) and subparagraph (4) and (5) clearly specifies when a cooling or heat pump coil and air conditioner blower are installed with a furnace or heating appliance they shall be tested and listed in combination for heating and safety performance by a nationally recognized testing agency(ies). Additionally, the cooling or heat pump systems to be installed in Manufactured Housing shall be certified, listed and rated based on US Department of Energy test procedures which are listed by AHRI and shall be tested and listed in combination for heating and safety performance by a nationally recognized testing agency.

REVOLV indoor coils are designed specifically for use with various models of manufactured housing gas or electric furnaces in both down-flow and up-flow applications. **A different pan will be required on up flow oil furnaces.**

These instructions are primarily intended to assist qualified individuals trained and experienced in the proper installation of this type of equipment. Some state codes require installation and service personnel to be licensed. Refer to authorities having jurisdiction for additional guidance. Remember that the Clean Air Act of 1990 requires technician certification for handling refrigerant.

NOTE: EFFICIENCY AND CAPACITY RATINGS ARE LISTED IN CURRENT AHRI UNITARY DIRECTORY [UNDER SUMMIT MANUFACTURING] FOR REVOLV COIL MODEL NUMBERS MATCHED WITH OUTDOOR CONDENSING OR HEAT PUMP UNITS. AIR CONDITIONING COIL MATCHES ARE LISTED IN INDOOR COIL MANUFACTURER AIR CONDITIONING SECTION. HEAT PUMP COIL MATCHES ARE LISTED IN INDOOR COIL MANUFACTURER HEAT PUMP SECTION. INCORRECTLY MATCHED SYSTEMS MAY NOT WORK PROPERLY AND MAY VOID MANUFACTURER LIMITED WARRANTY.

Current Status; R-22 coils no longer listed but can be ordered as a replacement. R-410A coils are currently listed in AHRI and can be ordered as a replacement.

Revolv Model Number	Refrigerant Connection	Holding Charge	TXV Device Installed on Coil	Current Status, Active or Discontinued	Revolv Model Number	Refrigerant Connection	Holding Charge	TXV Device Installed on Coil	Current Status, Active or Discontinued
1836QA-N	# 6 & #11 QC	Nitrogen	TXV (R-22)	Replacement	1841S4A	Sweat	Nitrogen	TXV (R-410A)	Active
1836SA	Sweat	Nitrogen	TXV (R-22)	Replacement	1843S4A	Sweat	Nitrogen	TXV (R-410A)	Active
1849QA-N	# 6 & #11 QC	Nitrogen	TXV (R-22)	Replacement	1843M4A	# 6 & #11 QC	R-410A	TXV (R-410A)	Active
1849SA	Sweat	Nitrogen	TXV (R-22)	Replacement	1843P4A	# 6 & #11 QC	R-410A	TXV (R-410A)	Active
1854QA-N	# 6 & #11 QC	Nitrogen	TXV (R-22)	Replacement	1843Q4A	# 6 & #11 QC	R-410A	TXV (R-410A)	Active
1854SA	Sweat	Nitrogen	TXV (R-22)	Replacement	1844S4A	Sweat	Nitrogen	TXV (R-410A)	Active
					1844M4A	# 6 & #11 QC	R-410A	TXV (R-410A)	Active
1829S4A	Sweat	Nitrogen	TXV (R-410A)	Active	1847S4A	Sweat	Nitrogen	TXV (R-410A)	Active
1830S4A	Sweat	Nitrogen	TXV (R-410A)	Active	1854S4A	Sweat	Nitrogen	TXV (R-410A)	Active
1830M4A	# 6 & #11 QC	R-410A	TXV (R-410A)	Active	1854M4A	# 6 & #11 QC	R-410A	TXV (R-410A)	Active
1830P4A	# 6 & #11 QC	R-410A	TXV (R-410A)	Active	1854P4A	# 6 & #11 QC	R-410A	TXV (R-410A)	Active
1830Q4A	# 6 & #11 QC	R-410A	TXV (R-410A)	Active	1854Q4A	# 6 & #11 QC	R-410A	TXV (R-410A)	Active
1831S4A	Sweat	Nitrogen	TXV (R-410A)	Active	1851S4A	Sweat	Nitrogen	TXV (R-410A)	Active
1836S4A	Sweat	Nitrogen	TXV (R-410A)	Active	1855S4A*	Sweat	Nitrogen	TXV (R-410A)	Active
1836M4A	# 6 & #11 QC	R-410A	TXV (R-410A)	Active	1855M4A*	# 6 & #11 QC	R-410A	TXV (R-410A)	Active
1836P4A	# 6 & #11 QC	R-410A	TXV (R-410A)	Active	1856S4A	Sweat	Nitrogen	TXV (R-410A)	Active
1836Q4A	# 6 & #11 QC	R-410A	TXV (R-410A)	Active	1856M4A	# 6 & #11 QC	R-410A	TXV (R-410A)	Active
1837S4A	Sweat	Nitrogen	TXV (R-410A)	Active	1856P4A	# 6 & #11 QC	R-410A	TXV (R-410A)	Active
					1856Q4A	# 6 & #11 QC	R-410A	TXV (R-410A)	Active

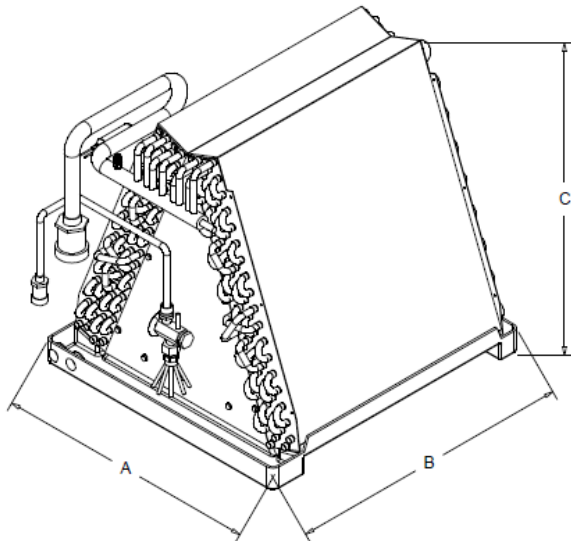

ATTENTION!

REVOLV indoor coils have a TXV as the metering device. However, the sensor bulb is only mounted on the quick connect models. Therefore, on sweat connect coils, after the suction and liquid line have been properly connected to the coil the bulb can be mounted on the suction line. Many times, due to space limitations in the manufactured housing applications it will require the sensor bulb to be mounted vertically. If that is the case the bulb should be located at least 6" away from a bend (elbow) and fastened on the tubing side opposite the plane of the bend. The bulb should be insulated using the thermal insulation to protect it from the effects of the surrounding ambient temperature.

CAUTION!

All Sweat Connect and R-22 TXV Quick Connect and Sweat Connect coils are shipped from factory pressurized with nitrogen. They do not contain any HCFC22 or HFC410A. Relieve nitrogen pressure before opening the refrigerant circuit.



NOTE!

REVOLV coils and other accessories installed when air conditioning is added to manufactured housing furnaces will comply with HUD regulations requiring third party approvals. Efficiency and capacity ratings as required by HUD / DOE are listed in the current AHRI directory for *REVOLV* model numbers [see Summit Manufacturing] matched with the outdoor units. These coil ratings are based on air quantities consistent with those that are encountered in typical manufactured housing air conditioning and heat pump applications.

GENERAL COIL INSTALLATION NOTES

ALL COILS SHOULD BE CHECKED FOR PRESSURE BEFORE LEAVING THE DISTRIBUTOR OR BEFORE INSTALLATION! IF THERE IS NO PRESSURE PRESENT, THE COIL MAY HAVE DEVELOPED A LEAK DURING SHIPMENT AND SHOULD BE RETURNED TO THE POINT OF PURCHASE FOR EXCHANGE.

1. On a quick connect coil, test for pressure by pushing against the diaphragm located inside the quick connect fitting on the suction manifold. If you are not able to depress the diaphragm, the coil contains an R-410A holding charge. To test for pressure on a sweat connect coil, remove the cap or flare nut on the Schrader fitting and depress the core valve located on the suction manifold.
2. The blower and duct system must be properly sized in order to provide adequate cooling and heating performance. Select the correct motor speed tap on the furnace blower to give the required CFM needed for rated cooling capacity or upgrade the blower assembly to attain the proper CFM. Return air filters of generous size must be provided, in order to avoid contaminating the coil, blower and ductwork, or restricting necessary airflow. Failure to deliver the proper air flow across the indoor coil will cause system and/or component problems, i.e. TXV performance problems.
3. **It is essential that the indoor coil and outdoor unit be properly matched and charged with the proper amount of**

refrigerant. Incorrect charge levels will result in inefficient operation. See more details in installation instructions for the outdoor unit.

4. It is recommended that the coil be sprayed with liquid detergent thoroughly and rinsed thoroughly before installation to assure proper drainage of condensate from the coil fins to eliminate water blowoff and to assure maximum coil performance. If not sprayed, approximately 50 hours of break in time is required to achieve the same results.
6. Always be sure coil is installed level or sloped slightly toward primary and secondary (the higher of the two) drain fittings. If mandated by code, connect both drain lines to open drain, but never to a closed sewer. Pitch drain lines away from drain pan. **Always**, test drain lines with water before operating. This step is mandatory in all manufactured housing installations. Reduction in size of the drain lines is not recommended and many times not allowed.
7. **A WATER TRAP** is recommended on all coil applications, but **IS REQUIRED ON PULL THROUGH INSTALLATIONS ON ELECTRIC FURNACES. FAILURE TO PROVIDE CAN RESULT IN IMPROPER DRAINAGE OR POTENTIAL SHOCK HAZARD.**

ATTENTION!

It is mandatory to use an emergency auxiliary drain above a finished ceiling. It must have its own drain line (a water trap is not necessary) with its output into an open drain (not a closed sewer). It should allow easy visual inspection so that if condensate flow is seen the homeowner knows that the coil drain pan lines are plugged and need maintenance.

8. Refrigerant piping is critical on any coil installation when the outdoor unit is to be located below the level of the coil. For proper piping design considerations, refer to the guidelines furnished by the manufacturer of the outdoor unit.
9. On QC coils lubricate threads and O-ring with POE oil for proper mating. Check all field installed refrigerant connections, both quick and sweat, with electronic leak detector, halide torch, or soap bubbles.
10. Refer to installation instructions provided with the outdoor unit, gas or electric furnace, and line sets for completion of system installation.

INSTALLATION WITH ELECTRIC FURNACE:

Typical electric furnace installation consists of a coil without cabinet installed on top of a downflow furnace or the coil inside a cavity on either a downflow or upflow furnace.

The following Revolv installation kits are unique to manufactured housing air conditioning and these kits are required to complete the installation.

1. Filter (1122515) can be used on coils mounted on down flow electric furnaces without cavities. [See #3 below for optional filter system]
2. A Downflow Coil Support Shelf Kit with insulation (3500.8941) for “C” & “D” Series and a Coil Support Shelf Kit without Insulation (3500.8941B) is required to support coils in Coleman furnaces.
3. Coil & Filter Cabinet (13010001) are recommended and many times required for Nordyne furnaces as a preferred filter option.

Installation procedure:

1. Turn off electrical power to the furnace by turning off breaker in house panel. **CAUTION: Furnace may be connected to more than one supply circuit. Do not use furnace disconnect only. Check power at furnace to insure power is off.**
2. Remove filter at top of furnace cabinet (Nordyne or Coleman only).
3. Remove refrigerant line knockout at top of furnace (Mortex & Nordyne only).
4. Install insulation if needed.
5. Attach drain pan gasket provided with coil to underside of coil pan and center evaporator coil on furnace. See figure A on page 5.
6. Attach filters to sides of coil.
7. Route low voltage wiring, refrigerant lines and drain tubing through floor penetration.
WARNING: If drain hose is below 40 Deg F during installation warm before expanding and/or forming.
8. Form 3” deep trap using (field supplied) tape and (provided) flexible drain hose and connect to coil pan drain securing with clamp provided. See figure B on page 5. The most efficient use of drain material is to form a “P” trap under the house. **All pull through furnaces must have a condensate trap in the drain line.**
9. Connect refrigerant lines per instructions with line set. Make sure to lubricate quick connect threads with refrigeration oil for proper mating. Refer to outdoor unit installation instructions for additional information on line set hook-ups and proper torque values.
10. With the coil in place seal off any openings at top or bottom of furnace to prevent air leakage or air bypass (use silver backed tape provided, if needed).
11. Turn power on to furnace.
12. Replace front door.

INSTALLATION WITH GAS FURNACE:

ATTENTION!

Do not install any coil containing refrigerant in a gas furnace which is to be operated during the heating season without attaching the refrigerant lines to the coil. Possible coil damage will result from excessive pressure build up during heating operation.

Typical downflow gas furnace installation consists of a coil without cabinet installed in the cavity of a downflow furnace. Coil with plastic pan is not suitable for upflow oil furnaces.

Installation procedure:

1. Turn off electrical power to furnace.
2. Remove the lower front panel of the furnace, and re-route any gas piping in front of coil compartment as required to install coil.

WARNING!

Contractor must comply with all local, state, and federal codes and regulations when working with gas piping. Personal injury or death may result from improper installations!

3. Remove the coil cover panel(s).
4. Remove knockouts in front left bottom of furnace for routing of refrigerant lines, low voltage wiring, and condensate drain.
5. Attach drain pan gasket and drain elbow provided, see figure “A” & “B”, as shown on page 5, and center coil in coil cavity.
6. Remove knockouts from coil cover panel(s), cut fiberglass insulation covering openings and reinstall cover.
7. Connect drain hose to condensate pan fitting, securing with clamp. See figure “B” on page 5.
8. Install silver backed tape provided to cover openings in interior panel door and over refrigerant lines to seal around lines
9. Connect refrigerant lines and make sure all connections are tight and without leaks.
10. Reconnect the gas piping if it was disconnected and seal off any openings at bottom of furnace. National, state and local codes must be followed.
11. Install filter if not located in furnace door.
12. Turn on gas/electrical supply and make final system check.
13. Replace front door.

SPECIAL CONSIDERATIONS FOR SELECTING HEAT PUMP COILS

The proper selections of indoor heat pump coils are much more critical than selection of indoor coils for air conditioning units. The differences are as follows:

1. Only indoor coils with expansion/check valve flow control devices may be used with outdoor heat pump units. These devices permit reversing refrigerant flow in the coils when changing from cooling to heating. All Revolv expansion valves and pistons have a built-in check making them heat pump capable when matched with the proper AHRI rated outdoor unit. **CAP TUBE OR FIXED RESTRICTOR COILS MUST NOT BE USED WITH HEAT PUMPS.**

2. **Matching of indoor coils for heat pumps demands that the heat rejection capacity, internal volume, and equivalent metering device of the matched coil be at least equal to that of the smallest internal volume matched coil recommended by outdoor unit manufacturer for that outdoor unit.**
3. **It is important that selection be based on Revolv guidelines for a specific coil with a specific metering device to be used with an outdoor heat pump unit of a specific make, series, and model number.**
4. Failure to conform to proper selection requirements will affect efficiency, charging, and reliability and may result in damage to the system or system components and void the manufacturer limited warranty.
5. The matching of specific indoor heat pump coils with specific outdoor heat pump units as certified in the heat pump section of the current AHRI Directory will assure proper and efficient operation of heat pump systems. See www.ahridirectory.org.

SPECIAL INSTRUCTIONS FOR CHARGING HEAT PUMP COILS

All Quick Connect Heat Pump systems are a hassle free application when the indoor coil and CFM (Min 360 / 12M BTUs) match. The QC systems are designed at 5 to 9 degrees sub cooling in the cooling mode depending on the size system.

When using the Revolv sweat connect indoor coils the installer should be sure the system is properly matched. The R-410A systems must be listed in AHRI. The R-22 replacement coils are the only exception. Existing R-22 coils must be matched with the outdoor unit. If the indoor-outdoor listing is not available the coil model number should be noted so the proper replacement is used. If the indoor model number is not available then a description of the existing coil must be noted, such as; coil face area (aluminum area) and number of rows of copper (2-Row, 3-Row or 4-Rows).

Contact Tech Support if problems are encountered during the installation process and all other factors above are correct, such as; air flow, AHRI listing, etc.

SPECIAL METERING DEVICE INSTRUCTIONS FOR TXVs AND PISTON COILS

All Revolv Thermal Expansion Valves have a built in check system for heat pump applications and can be used on both A/C and H/P applications. Revolv offers three sizes R-410A TXVs, the 18R72DB0003 TXV has an operational range of 1.5-3.0 Ton (1830 & 1836) The R72DB0004 valve has an operational range of 2.5-4.0+ Ton (1843, 1854, 1851, 1855) depending on coil size and application. The R72DB0044 valve has an operational range of 3.0-6.0 Ton (1856) depending on application. This valve is super heat adjustable but set at 8-10 degrees at the bulb location. Other refrigerant valves are available. The Revolv QC coils shipped from the factory with the TXV mounted in the distributor body has the equalizer bulb mounted on the suction manifold. The sweat connect does not have the bulb mounted. This is a safety feature to allow the torching of the suction line without damaging the TXV from the heat of the torch. The bulb should be installed on the horizontal run of the suction manifold, if possible. Good contact between the bulb and the copper line is mandatory. See "Horizontal Bulb Locations guide below.

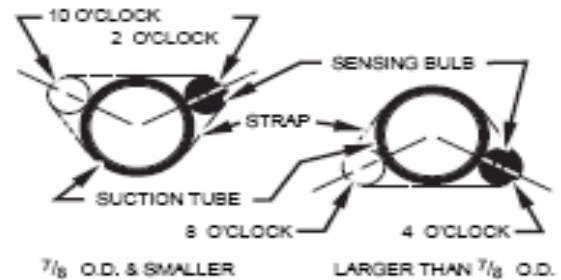

Horizontal Bulb Locations

If the bulb is made on the vertical run the bulb should be located at least 6 inches from any bend and mounted on the tubing side opposite the plane of the bend. On this location the bulb should be positioned with the capillary tube at the top. The bulb should be insulated using thermal insulation to protect it from the effect of the surrounding ambient temperature.

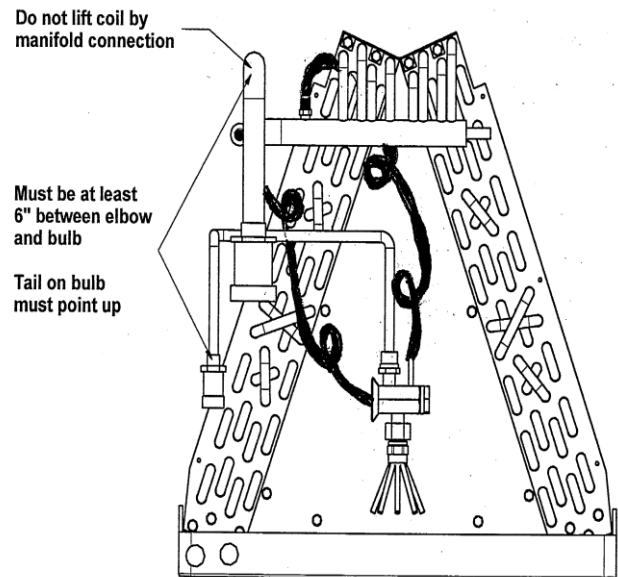

Revolv coils use the Chatleff type distributor body that accepts a screw on TXV or accepts a Chatleff style piston. All metering devices, both pistons and TXVs, have a relationship to the outdoor unit. The proper metering device allows for proper system operation but does not increase or decrease the capacity. The system capacity is determined by the relationship of the indoor-outdoor combination and air flow.

The use of the TXV is an advantage and allows for a wider operational range when matched with the proper outdoor unit. In manufactured housing the largest problem associated with a TXV is dirty coil and / of low air flow. If opening the distributor body is required check condition of Teflon O-Ring and torque the body at 10 lb-ft when closing system. Replace the O-Ring if necessary.

THERMAL EXPANSION VALVE INSTALLATION INSTRUCTIONS

A. INTRODUCTION

Thermal expansion valve (TXV) can be used on both heat pump and air conditioning applications. All TXVs have a built-in check valve making them heat pump capable. All are externally equalized with non-adjustable superheat and are available with non-bleed construction. Hard start capability for outdoor units is required when non-bleed valve is used. The external equalizer line attached to the TXV has a female flare nut with built in Schrader valve depressor that attaches to the Schrader valve port provided on most coils.

B. INSTALLATION NOTES

With reference to Figure 1, the TXV assembly is to be installed between the flowrator distributor and the existing liquid line attached to the flowrator distributor.

**WARNING: COIL IS PRESSURIZED.
RELIEVE PRESSURE BEFORE INSTALLING TXV
BY DEPRESSING SCHRADER VALVE ON COIL
MANIFOLD IF NITROGEN, OR RECLAIM
REFRIGERANT IF COIL HAS HOLDING CHARGE.**

C. INSTALLATION STEPS ARE AS FOLLOWS:

1. After coil pressure has been relieved, turn the female swivel nut counter-clockwise to remove.
2. Remove the piston from the flowrator distributor fitting using a small diameter wire or paper clip (ALWAYS REMOVE THE PISTON FROM DISTRIBUTOR BODY WHEN TXV IS INSTALLED).
3. Attach the TXV by connecting the female swivel nut on TXV outlet to the flowrator distributor (aligning Teflon seal first) and torque swivel nut to 10-30 ft. lb.
4. Attach liquid line with female swivel nut to male rotalock fitting on TXV inlet (aligning Teflon seal first) and torque swivel nut to 10-30 ft. lb.

5. Remove the cap on Schrader valve port on coil manifold. Attach equalizer tubing with 1/4" female flare nut that includes depressor to this male Schrader port. Torque flare nut to 10-30 ft. lb. **If using a different brand TXV, you must remove the schrader valve core prior to attaching the equalizer tube.**
6. Install the TXV bulb to the suction manifold of coil or the suction line using the two bulb clamps, or single large clamp, furnished with kit.
 - a. Bulb should be installed on a horizontal run of the manifold if possible. On line 7/8" OD and smaller the bulb should be installed at 2 or 10 o'clock. With line larger than 7/8" OD, the bulb should be installed in a position of about 4 or 8 o'clock.

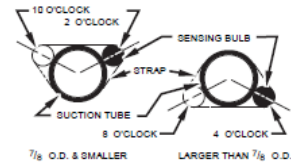

Horizontal Bulb Locations

- b. If bulb installation is made on a vertical run, the bulb should be located at least 6 inches from any bend, and on the tubing side opposite the plane of the bend. On vertical bulb installations, the bulb should be positioned with bulb capillary tube at the top.
- c. The bulb should be insulated using thermal insulation to protect it from the effect of the surrounding ambient temperature.

TXV BULB LOCATION DIAGRAM

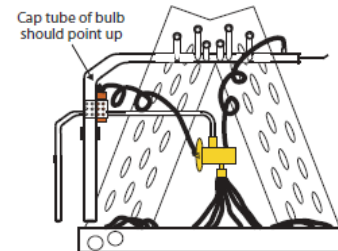

Vertical Riser Application

7. After completing installation of TXV (including equalizer tube), it will be necessary to leak check the coil and evacuate the coil through the service access fittings of liquid and suction line valves. SEE COIL AND UNIT INSTALLATION INSTRUCTIONS.
8. For additional information on TXV operation and application see Sporlan Bulletin 10-9 which is located at the following web address.
<http://www.parker.com/literature/Sporlan/Sporlan%20pdf%20files/Sporlan%20pdf%20010/10-9.pdf>

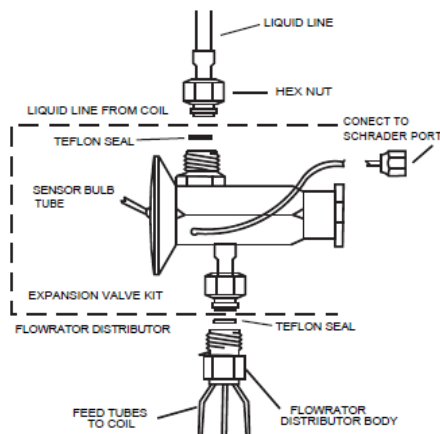

Figure 1

Figure "A" Drain Pan Gaskets

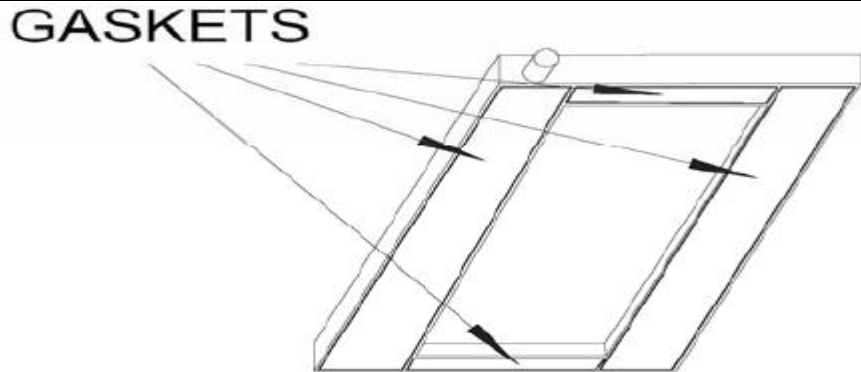

Figure "B" Drain Hose

THE ACCESSORY PACKAGE TO BE USED WITH THE MANUFACTURED (MOBILE) HOME PLASTIC PAN CONTAINS
A

90 DEGREE ELL THAT CAN BE SCREWED IN THE LEFT DRAIN FITTING, THEN TURNED DOWN AND EXIT THE
FURNACE

HAND TIGHTEN ONLY – OVERTIGHTING CAN RESULT IN CRACKS IN THE DRAIN PAN
ENCLOSED DRAIN HOSE WILL SLIP OVER THE FITTING OR A STANDARD PVC FITTING CAN BE USED IF CODE
REQUIRES.

RIGHT DRAIN CONNECTION HAS A PLUG IN IT TO PREVENT FLOW UNLESS A SECONDARY DRAIN IS REQUIRED.
A STRAIGHT FITTING CAN BE USED FOR THE AUXILIARY DRAIN WHERE REQUIRED (FIELD SUPPLIED).

REMOVE PLUG AND INSERT FITTING, THEN TURN DOWN USING A STANDARD 3/4" PVC ELL.
INSTALLATION OF A COLLAPSIBLE HOSE ON SINGLE / AUXILIARY CONDENSATE DRAIN CONNECTION IS
RECOMMENDED.

CAUTION – BEFORE INSTALLING COIL IN FURNACE, SEE FIGURE 2.

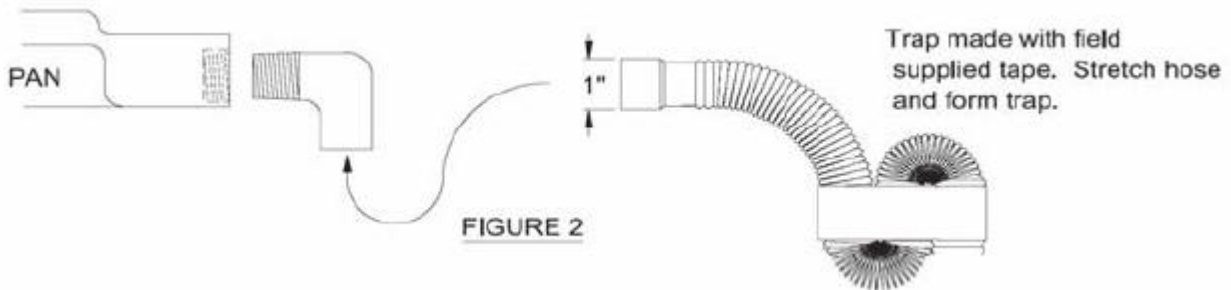

SLIP 1" ID SECTION OF HOSE ONTO 90 DEGREE DRAIN FITTING.

HOSE IN SOME CASES IS VERY TIGHT BUT IT WILL STRETCH AS IT IS WORKED ON.

DRAIN HOSE CAN BE IN PLACE DURING INSTALLATION PROVIDING THE CLAMPS ARE SECURELY FASTENED.

IF THE DRAIN HOSE MUST BE REMOVED TO COMPLETE THE INSTALLATION, MAKE SURE THE HOSE IS
STRETCHED,

REATTACHED AND SECURELY FASTENED WITH THE CLAMPS BEFORE COMPLETING THE INSTALLATION

NOTE: Good preventive maintenance on heat pumps is critical to ensure proper airflow across the coils. Low airflow on indoor coils during winter months causes high head pressures and premature compressor damage due to oil breakdown. This problem is normally the result of a dirty air filter. The installer should instruct the homeowner of the importance of keeping filters clean.

CONTACT US FOR HELP OR FOR ANY COMMENTS ON OUR PRODUCTS.

As we strive to better serve our customers like you, we are always ready to help you. We also welcome any comments from our customers concerning quality and improvements that could be made to our products.

Thank you for the purchase of our product.

61BA0010D