

## SFP-1M-BX54-D-80-C-AO

Cisco® Compatible TAA 100Base-BX SFP Transceiver (SMF, 1550nmTx/1490nmRx, 80km, LC, DOM)

### Features

- INF-8074 and SFF-8472 Compliance
- Simplex LC Connector
- Commercial Temperature 0 to 70 Celsius
- Single-mode Fiber
- Hot Pluggable
- Excellent ESD Protection
- Metal with Lower EMI
- RoHS Compliant and Lead Free



### Applications

- 100Base Ethernet
- Access and Enterprise

### Product Description

This Cisco® compatible SFP transceiver provides 100Base-BX throughput up to 80km over single-mode fiber (SMF) using a wavelength of 1550nmTx/1490nmRx via an LC connector. This bidirectional unit must be used with another transceiver or network appliance of complementing wavelengths. It can operate at temperatures between 0 and 70C. Our transceiver is built to meet or exceed OEM specifications and is guaranteed to be 100% compatible with Cisco®. It has been programmed, uniquely serialized, and tested for data-traffic and application to ensure that it will initialize and perform identically. All of our transceivers comply with Multi-Source Agreement (MSA) standards to provide seamless network integration. Additional product features include Digital Optical Monitoring (DOM) support which allows access to real-time operating parameters. This transceiver is Trade Agreements Act (TAA) compliant. We stand behind the quality of our products and proudly offer a limited lifetime warranty.

AddOn's transceivers are RoHS compliant and lead-free.

TAA refers to the Trade Agreements Act (19 U.S.C. & 2501-2581), which is intended to foster fair and open international trade. TAA requires that the U.S. Government may acquire only "U.S.-made or designated country end products."



## Regulatory Compliance

- ESD to the Electrical PINs: compatible with MIL-STD-883E Method 3015.4
- ESD to the LC Receptacle: compatible with IEC 61000-4-3
- EMI/EMC compatible with FCC Part 15 Subpart B Rules, EN55022:2010
- Laser Eye Safety compatible with FDA 21CFR, EN60950-1& EN (IEC) 60825-1,2
- RoHS compliant with EU RoHS 2.0 directive 2015/863/EU

## Absolute Maximum Ratings

Parameter	Symbol	Min.	Typ.	Max.	Unit
Operating Relative Humidity	RH	5		85	%
Operating Case Temperature	Tc	0		70	°C
Storage Temperature	Tstg	-40		85	°C
Maximum Supply Voltage	Vcc	-0.5		3.6	V
Supply Current	Icc			300	mA
Data Rate	OC-3		155		Mbps
	100M		100		

## Electrical Characteristics (VCC=3.14V to 3.46V)

Parameter	Symbol	Min.	Typ.	Max.	Unit	Notes
Power Supply Voltage	Vcc	3.15	3.3	3.47	V	
<b>Transmitter</b>						
LVPECL Inputs (Differential)	Vin	400		2000	mVpp	AC Coupled Inputs (Note1)
Input Impedance (Differential)	Zin	85	100	115	Ω	Rin > 100KΩ @DC
TX_Dis	Disable	2		Vcc + 0.3	V	
	Enable	0		0.8	V	
TX_Fault	Fault	2		Vcc + 0.3	V	
	Normal	0		0.5	V	
<b>Receiver</b>						
LVPECL Outputs (Differential)	Vout	400		2000	mVpp	AC Coupled Outputs (Note1)
Output Impedance (Differential)	Zout	85	100	115	Ω	
TX_Disable Assert Time	T_off			10	Us	
RX_Los	LOS	2		Vcc + 0.3	V	
	Normal	0		0.8	V	
MOD_DEF(0.2)	VOH	2.5			V	With Serial ID
	VOL	0		0.5	V	

**Notes:**

1. LVPECL logic, internally AC coupled.

**Optical Characteristics**

Parameter	Symbol	Min.	Typ.	Max.	Unit	Notes
9µm Core Diameter SMF	L		120		km	
Data Rate			155		Mbps	
<b>Transmitter</b>						
Center Wavelength	$\lambda_c$	1510	1550	1580	nm	
Side Mode Suppression Ratio	SMSR	30			dB	
Spectral Width (-20dB)	$\Delta\lambda$			1	nm	
Average Output Power	Pout	0		5	dBm	1
Extinction Ratio	ER	9			dB	2
Rise/Fall Time(20% - 80%)	tr/tf			1.5	ns	
Total Jitter	TJ			1.5	ns	
Pout@TX Disable Asserted	Pout			-45	dBm	
Output Optical Eye	IUT-T G.957 Compliant					
<b>Receiver</b>						
Center Wavelength	$\lambda_c$	1470		1570	nm	
Receiver Sensitivity	Pmin			-34	dBm	3
Receiver Overload	Pmax	0			dB	
LOS Assert	LOSA	-45			dBm	
LOS De-Assert	LOSD			-35	dBm	
LOS Hysteresis	LOSH	1			dB	

**Notes:**

1. Output power is measured by coupling into a 9/125nm single-mode fiber.
2. Filtered, measured with a PRBS  $2^{23}-1$  test pattern @ 155Mbps.
3. Minimum average optical power is measured at BER less than  $1E-12$  and PRBS  $2^{23}-1$  test pattern.

## Pin Descriptions

Pin	Symbol	Name/Descriptions	Plug Seq.	Notes
1	VEET	Transmitter ground.	1	5
2	TX Fault	Transmitter Fault Indication.	3	1
3	TX_Disable	Transmitter Disable. Module disables on high or open.	3	2
4	MOD_DEF 2	Module Definition 2. Two wire serial ID interface.	3	3
5	MOD_DEF 1	Module Definition 1. Two wire serial ID interface.	3	3
6	MOD_DEF 0	Module Definition 0. Grounded within the module.	3	3
7	Rate Select	No connection required.	3	Function not available
8	LOS	Loss of Signal.	3	4
9	VeeR	Receiver ground.	1	5
10	VeeR	Receiver ground.	1	5
11	VeeR	Receiver ground.	1	5
12	RD-	Receiver Inverted Data out.	3	6
13	RD+	Receiver Data out.	3	7
14	VeeR	Receiver ground. $3.3 \pm 5\%$	1	5
15	VccR	Receiver power. $3.3 \pm 5\%$	2	7
16	VccT	Transmitter power.	2	7
17	VeeT	Transmitter ground.	1	5
18	TD+	Transmitter Data in.	3	8
19	TD-	Transmitter Inverted data in.	3	8
20	VeeT	Transmitter ground.	1	5

### Notes:

- TX Fault is an open collector/drain output, which should be pulled up with a 4.7K-10k resistor on the host board. Pull up voltage between 2.0V and  $V_{ccT}/R + 0.3V$ . When high, output indicates a laser fault of some kind. Low indicated normal operation. In the low state, the output will be pulled to  $<0.8V$ .
- TX disables is an input that is used to shut down the transmitter optical output. It is pulled up within the module with a 4.7-10K resistor. It states:
  - Low (0 - 0.8V): Transmitter on ( $>0.5$ ,  $<2.0V$ ): Undefined;
  - High (2.0 – 3.465V): Transmitter Disable Open: Transmitter Disabled;
- Mod-Def 0, 1, 2. These are the module definition pins. They should be pulled up with a 4.7K – 10K resistor on the host board. The pull up voltage shall be  $V_{ccT}$  or  $V_{ccR}$ .
  - Mod-Def 0 is grounded by the module to indicate that the module is present;
  - Mod-Def1 is the clock line of two wire serial interface for serial ID;
  - Mod-Def2 is the data line of two wire serial interface for serial ID.
- LOS (Loss of Signal) is an open collector/drain output, which should be pulled up with a 4.7K – 10K resistor. Pull up voltage between 2.0V and  $V_{ccT}/R + 0.3V$ . When high, this output indicated the received optical power is below the worst-case receiver Sensitivity (as defined by the standard in use). Low indicated normal operation. In the low state, the output will be pulled to  $<0.8V$ .

5. VeeR and VeeT may be internally connected within the SFP module.
6. RD -/+ : These are the differential receiver outputs. They are AC coupled 100 differential lines which should be terminated with 100 (differential) at the user SERDES. The AC coupling is done inside the module and thus not required on the host board. The voltage swing on these lines will be between 400 and 2000 mV differential (200 - 1000 mV single ended) when promptly terminated.
7. VccR and VccT are the receiver and transmitter power supplies. They are defined as a  $3.3V \pm 5\%$  at the SFP connector pin. Maximum supply current is 300mA. Recommended host board power supply filtering is show below. Inductors with DC resistance of less that  $1\Omega$  should be used in order to maintain the required voltage at the SFP input pin with 3.3V supply voltage. When the recommended supply-filtering network is used, hot plugging of the SFP transceiver module will result in an rush current of no more than 30m,A greater than the steady state value. VccR and VccT may be internally connected within the SFP transceiver module.
8. TD-/+ : These are the differential transmitter inputs. They are AC-coupled, differential lines with 100 differential terminations inside the module. The AC coupling is done inside the module and is thus not required o the host board. The inputs will accept differential swings of 400 – 2000mV(200- 1000mV single-ended).

### Electrical Pin-out Details

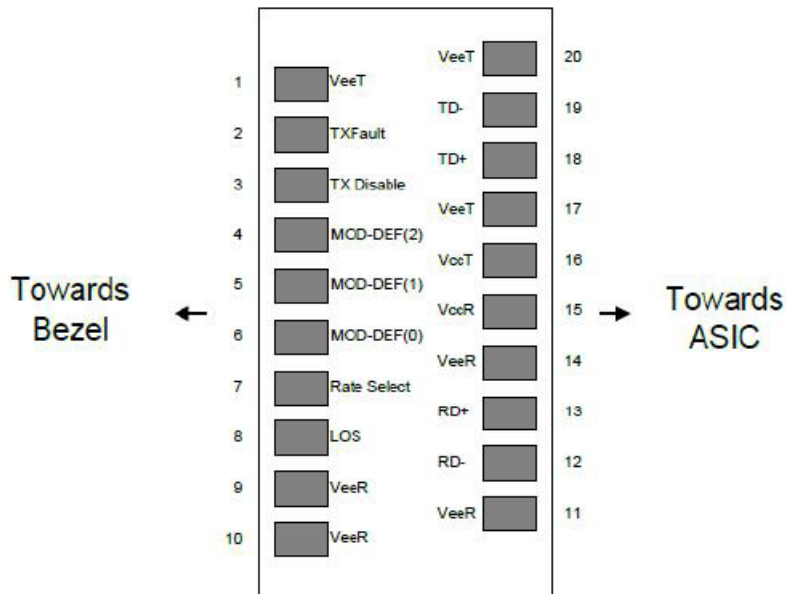

## 2 Wire Address

2 wire address 1010000X(A0h)

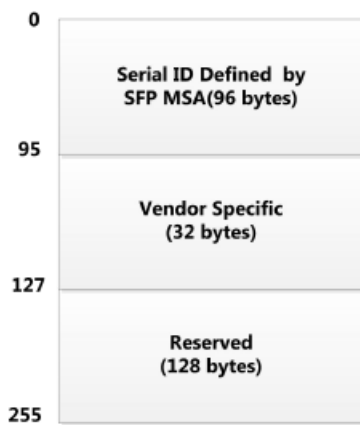

2 wire address 1010000X (A2h)

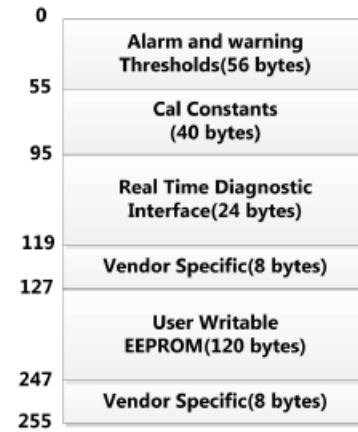

## Recommended Circuit Schematic

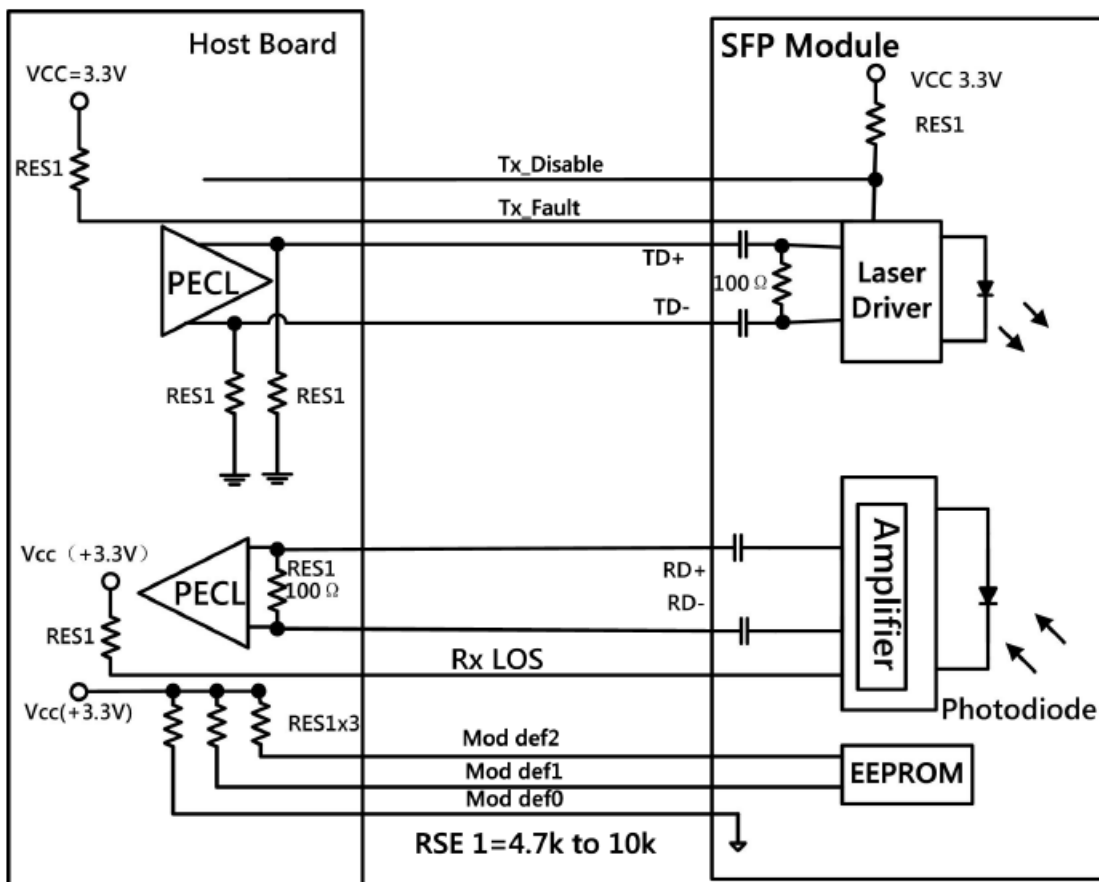

# Mechanical Specifications

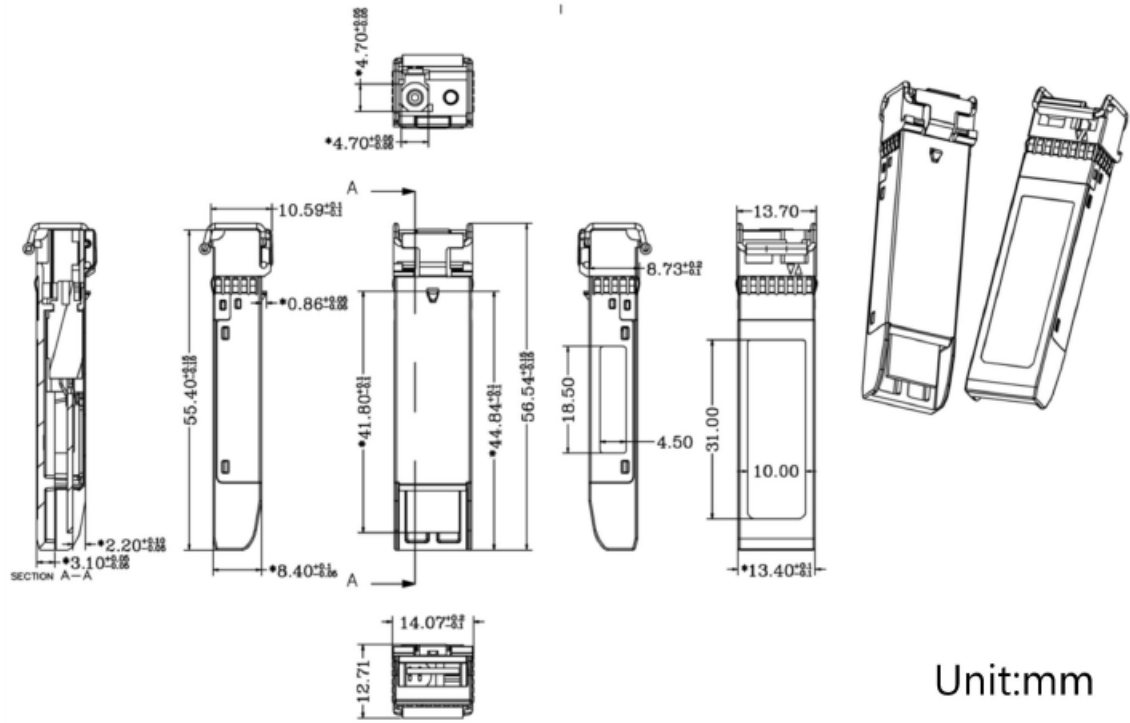

Unit:mm

## About AddOn Networks

In 1999, AddOn Networks entered the market with a single product. Our founders fulfilled a severe shortage for compatible, cost-effective optical transceivers that compete at the same performance levels as leading OEM manufacturers. Adhering to the idea of redefining service and product quality not previously had in the fiber optic networking industry, AddOn invested resources in solution design, production, fulfillment, and global support.

Combining one of the most extensive and stringent testing processes in the industry, an exceptional free tech support center, and a consistent roll-out of innovative technologies, AddOn has continually set industry standards of quality and reliability throughout its history.

Reliability is the cornerstone of any optical fiber network and is ingrained in AddOn's DNA. It has played a key role in nurturing the long-term relationships developed over the years with customers. AddOn remains committed to exceeding industry standards with certifications ranging from NEBS Level 3 to ISO 9001:2015 with every new development while maintaining the signature reliability of its products.



## U.S. Headquarters

Email: [sales@addonnetworks.com](mailto:sales@addonnetworks.com)

Telephone: +1 877.292.1701

Fax: 949.266.9273

## Europe Headquarters

Email: [salesemea@addonnetworks.com](mailto:salesemea@addonnetworks.com)

Telephone: +44 1285 842070