

SFP-1G-LH-OPC

Cisco® SFP-1G-LH Compatible 1000Base-LX (media interface) to 10G (host) adapting SFP+ Transceiver (SMF, 1310nm, 10km, LC)

Features

- 1310nm FP laser transmitter
- Build-in PHY supporting XFI/USXGMII interface
- Duplex LC Connector
- Single 3.3V Power Supply
- Receiver Loss of Signal Output
- Serial ID module on MOD (0-2)
- Class 1 laser safety certified
- Transmitter disable input
- Operating Temperature: 0 to 70 Celsius
- RoHS compliant and Lead-Free



Applications:

- 1000Base-LX Ethernet
- 1x Fibre Channel
- Access and Enterprise

Product Description

This Cisco® SFP-1G-LH compatible SFP transceiver provides 1000Base-LX throughput up to 10km over single-mode fiber (SMF) using a wavelength of 1310nm via an LC connector. It can operate at temperatures between 0 and 70C. Our transceiver is built to meet or exceed OEM specifications and is guaranteed to be 100% compatible with Cisco®. It has been programmed, uniquely serialized, and tested for data-traffic and application to ensure that it will initialize and perform identically. All of our transceivers comply with Multi-Source Agreement (MSA) standards to provide seamless network integration. This transceiver is Trade Agreements Act (TAA) compliant. We stand behind the quality of our products and proudly offer a limited lifetime warranty.

OptioConnect's transceivers are RoHS compliant and lead-free.

Absolute Maximum Ratings

Parameter	Symbol	Min.	Typ.	Max.	Unit	Notes
Maximum Supply Voltage	V _{CC}			4.0	V	
Storage Temperature	T _{stg}	-40		85	°C	
Operating Case Temperature	T _c	0		70	°C	
Operating Relative Humidity	RH	0		95	%	
Power Supply Voltage	V _{CC}	3.10	3.3	3.47	V	
Supply Current	I _{CC}			800	mA	
Power Dissipation	P _{DISS}			2.0	W	

Optical Characteristics

Parameter	Symbol	Min.	Typ.	Max.	Unit	Notes
Transmitter						
Launch Optical Power	P _o	-9.5		-3.0	dBm	1
Center Wavelength	λ _C	1270		1355	nm	
Extinction Ratio	ER	9.0			dB	
Spectral Width (RMS)	Δλ			4.0	nm	
Mask Margin		10				
POUT of OFF Transmitter	P _{off}			-30	dBm	
Eye Diagram	Complies with IEEE 802.3					
Receiver						
Center Wavelength	λ _C	1260		1620	nm	
Receiver Sensitivity	S			-19	dBm	2
Overload Input Optical Power	P _{in}	-3.0			dBm	
LOS De-Assert				-20	dBm	
LOS Assert		-30			dBm	
LOS Hysteresis		0.5		5	dB	3

Notes:

1. With SMF.
2. Measured with BER<10E⁻¹².
3. The LOS Hysteresis minimizes “chatter” on the output line. In principle, Hysteresis alone does not guarantee chatter-free operation.

Pin Descriptions

Pin	Symbol	Name/Description	Notes
1	VeeT	Transmitter Signal Ground.	1
2	Tx_Fault	Transmitter Fault Out (OC).	2
3	Tx_Disable	Transmitter Disable In (LVTTTL).	3
4	SDA	Module Definition Identifiers.	4
5	SCL	Module Definition Identifiers.	4
6	MOD_ABS	Module Definition Identifiers.	4
7	RS0	Receiver Rate Select (LVTTTL). Transmitter Rate Select (LVTTTL).	5
8	LOS	Loss of Signal Out (OC).	6
9	RS1	Receiver Rate Select (LVTTTL). Transmitter Rate Select (LVTTTL).	5
10	VeeR	Receiver Signal Ground.	7
11	VeeR	Receiver Signal Ground.	7
12	RD-	Receiver Negative Data Out (CML).	8
13	RD+	Receiver Positive Data Out (CML).	9
14	VeeR	Receiver Signal Ground.	7
15	VccR	Receiver Power Supply.	10
16	VccT	Transmitter Power Supply.	10
17	VeeT	Transmitter Signal Ground.	1
18	TD+	Transmitter Positive Data In (CML).	11
19	TD-	Transmitter Negative Data In (CML).	12
20	VeeT	Transmitter Signal Ground.	1

Notes:

- These pins should be connected to the signal ground on the host board.
- Logic "1" Output = Transmitter Fault.
Logic "0" Output = Normal Operation.
This pin is open collector compatible and should be pulled up to the Host_Vcc with a 10kΩ resistor.
- Logic "1" Input (or No Connection) = Laser Off.
Logic "0" Input = Laser On.
This pin is internally pulled up to the VccT with a 10kΩ resistor.
- Serial ID with SFF-8472 Diagnostics Module Definition pins should be pulled up to the Host_Vcc with 10kΩ resistors.
- These pins have an internal 33kΩ pull-down to ground. A signal on either of these pins will not affect module performance.
- This pin is open collector compatible and should be pulled up to the Host_Vcc with a 10kΩ resistor.
- These pins should be connected to the signal ground on the host board.
- Light On = Logic "0" Output Receiver Data output is internally AC coupled and series terminated with a 50Ω resistor.
- Light On = Logic "1" Output Receiver Data output is internally AC coupled and series terminated

with a 50Ω resistor.

10. This pin should be connected to a filtered +3.3V power supply on the host board.
11. Logic "1" Input = Light On Transmitter Data inputs are internally AC coupled and terminated with a differential 100Ω resistor.
12. Logic "0" Input = Light On Transmitter Data inputs are internally AC coupled and terminated with a differential 100Ω resistor.

Electrical Pin-Out Details

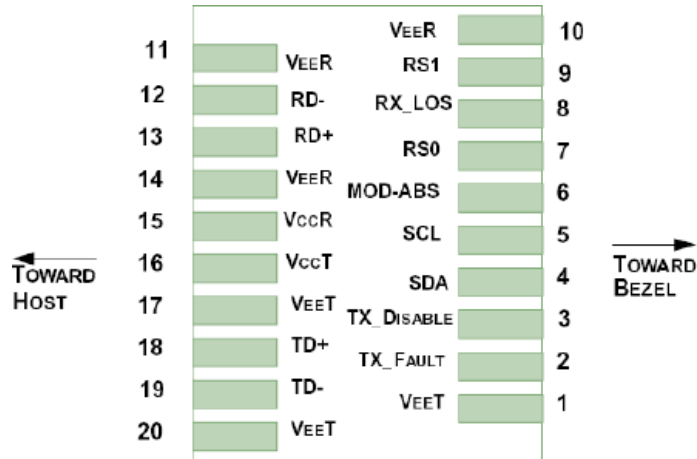

Recommended Circuit Schematic

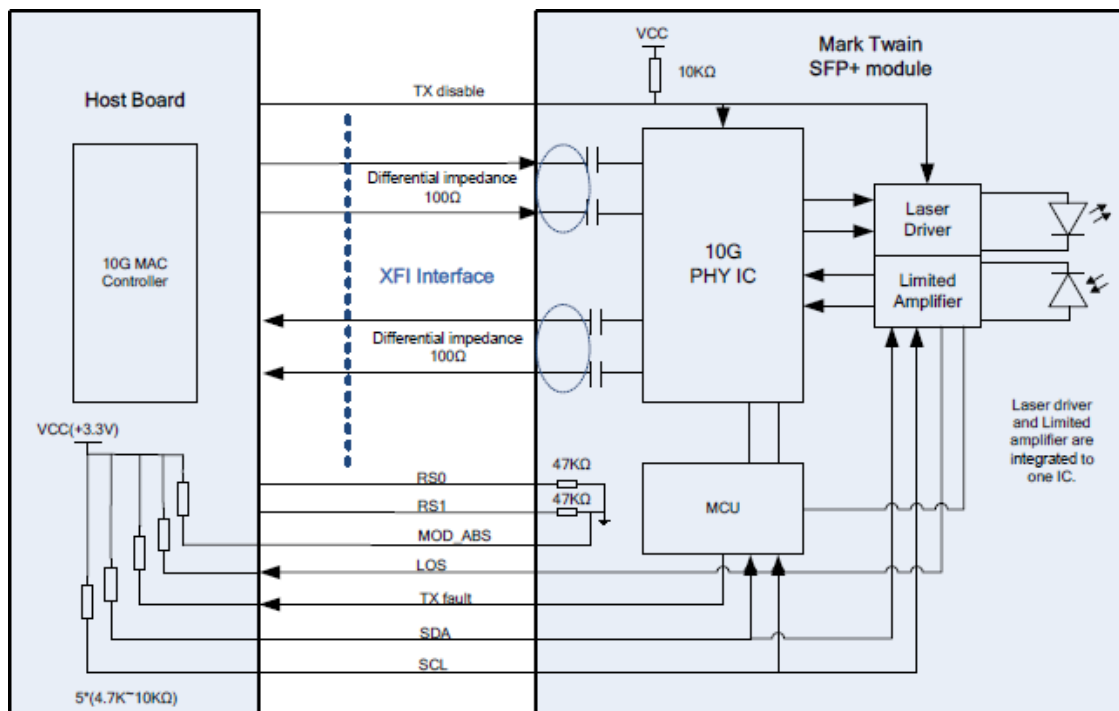

Mechanical Specifications

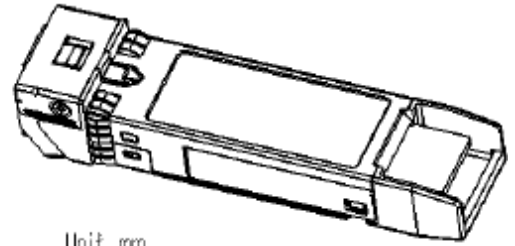
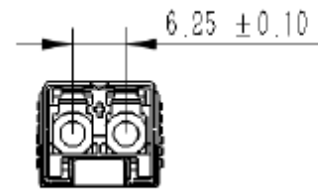
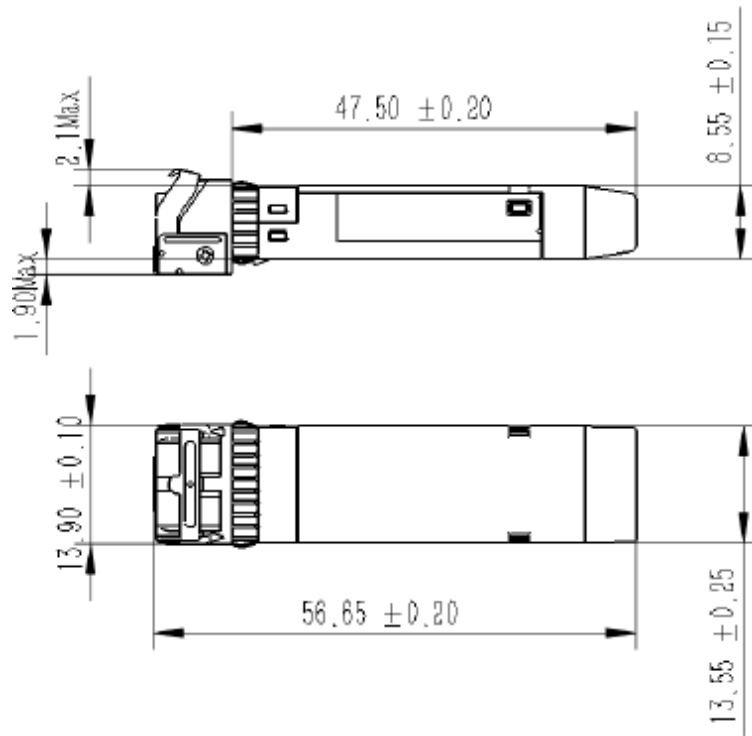

Unit: mm

OptioConnect

Innovation for the Future of High-Speed Networking

Who We Are

OptioConnect is reshaping the landscape of communication and high-speed networking through intelligent technology. With a core focus on cutting edge technology, we deliver smarter fiber optic solutions for enterprise networks, data centers, and next-gen telecom infrastructures.

What We Do

At OptioConnect, we fuse advanced engineering with intelligent automation to drive the future of networking. Our AI-integrated solutions are designed to optimize performance and streamline operations with:

- Superior Performance
- Network and traffic optimization
- Intelligent energy management
- Seamless OEM compatibility
- Scalable cost-efficiency

Smarter Networks by Design

Innovation isn't just a goal—it's our process. We embed AI and machine learning across our R&D and product lines, enabling adaptive performance, automated tuning, and faster deployment cycles. The result? Networks that don't just work—they learn, evolve, and outperform.

Our Team

Our engineers, data scientists, and network architects bring decades of experience and a future-focused mindset. We provide hands-on support with intelligent insights that turn complex challenges into simple solutions.

Our Mission

To deliver AI-enhanced connectivity that reduces cost, increases speed, and maximizes efficiency—empowering our partners to operate at the forefront of a rapidly evolving digital world.

Let's Connect

Discover how OptioConnect's intelligent infrastructure solutions can power your network's next leap forward.

www.optioconnect.com | info@optioconnect.com

