

SFP-10/25G-LR-20-C-AO

Cisco® Compatible TAA 10/25GBase-LR SFP28 Transceiver (SMF, 1310nm, 20km, LC, DOM)

Features

- Supports 24.33Gbps and 25.78Gbps Operating Data Rate with CDR Engaged Mode
- 1310nm Uncooled DFB-LD Transmitter
- Supports 9.95Gbps and 10.31Gbps Operating Data Rate with CDR Bypassed Mode
- Single 3.3V Power Supply
- Duplex LC Connector Interface
- Up to 20km Distance
- Power Dissipation: 1.2W
- Hot-Pluggable
- RoHS Compliant and Lead-Free
- Operating Temperature: 0 to 70 Celsius



Applications

- 25GBase Ethernet
- Access and Enterprise

Product Description

This Cisco® compatible SFP28 transceiver provides 25GBase-LR throughput up to 20km over single-mode fiber (SMF) using a wavelength of 1310nm via an LC connector. It is guaranteed to be 100% compatible with the equivalent Cisco® transceiver. This easy to install, hot swappable transceiver has been programmed, uniquely serialized and data-traffic and application tested to ensure that it will initialize and perform identically. Digital optical monitoring (DOM) support is also present to allow access to real-time operating parameters. This transceiver is Trade Agreements Act (TAA) compliant. We stand behind the quality of our products and proudly offer a limited lifetime warranty.

AddOn's transceivers are RoHS compliant and lead-free.

TAA refers to the Trade Agreements Act (19 U.S.C. & 2501-2581), which is intended to foster fair and open international trade. TAA requires that the U.S. Government may acquire only "U.S.-made or designated country end products."



Absolute Maximum Ratings

Parameter	Symbol	Min.	Typ.	Max.	Unit	Notes
Data Rate	DR	24.33		25.78	Gbps	1
	DR	9.95		10.31		2
Operating Case Temperature	Tc	0		70	°C	
Storage Temperature	Tstg	-40		85	°C	
Maximum Voltage	Vcc	-0.5		4.0	V	
Relative Humidity (Non-Condensing)	RH	0		85	%	
9µm Core Diameter SMF				20	km	

Notes:

1. CDR engaged mode.
2. CDR bypassed mode.
3. Exceeding any one of these values may destroy the device permanently.

Electrical Characteristics

Parameter	Symbol	Min.	Typ.	Max.	Unit	Notes
Supply Voltage	Vcc	3.135		3.465	V	
Supply Current	Icc			360	mA	
Transmitter						
CML Inputs (Differential)	VIN	200		900	mVp-p	1
Input Impedance (Differential)	ZIN		100		Ω	2
Tx_Disable Input Voltage - High		2		Vcc + 0.3	V	
Tx_Disable Input Voltage - Low		-0.3		0.8	V	
Receiver						
CML Outputs (Differential)	VOUT	300		1000	mVp-p	3
Rx_LOS Output Voltage - High		2		Vcc + 0.3	V	
Rx_LOS Output Voltage - Low		-0.3		0.8	V	

Notes:

1. AC coupled inputs.
2. Connected directly to Tx pins.
3. AC coupled outputs.

Optical Characteristics

Parameter	Symbol	Min.	Typ.	Max.	Unit	Notes
Transmitter						
Center Wavelength	λ_C	1295	1310	1325	nm	
Spectral Width (-20dB)	$\Delta\lambda$			1	nm	
Side-Mode Suppression Ratio	SMSR	30			dB	
Average Output Power @25.78Gbps	POUT	-0.5		5	dBm	
Output Power (OMA) @25.78Gbps	POMA	-1		5	dBm	
OMA Minus TDP	OMA-TDP	-2			dBm	
Extinction Ratio	ER	4			dB	
Transmitter Dispersion Penalty	TDP			2.7	dB	
Relative Intensity Noise	RIN			-130	dB/HZ	
Transmitter Reflectance				-26	dB	
Transmitter Eye Mask Definition: {X1, X2, X3, Y1, Y2, Y3} Hit Ratio 5E ⁻⁵ Hits Per Sample		{0.31, 0.40, 0.45, 0.34, 0.38, 0.4}				
Receiver						
Center Wavelength	λ_C	1295	1310	1365	nm	
Receiver Sensitivity (OMA)	RX _{OMA}			-14	dBm	1
Receiver Overload	P _{MAX}	2.5			dBm	2
Receiver Reflectance				-26	dB	
LOS De-Assert	LOSD			-16	dBm	
LOS Assert	LOSA	-30			dBm	
LOS Hysteresis	LOSH	0.5			dB	

Notes:

1. Measured with data rate @25.78Gbps with BER less than 5E⁻⁵ and PRBS 2³¹-1.
2. Targeted for long reach applications with high-power transmitter. Please ensure at least 3dB optical attenuation for optical loopback test.

Pin Descriptions

Pin	Symbol	Name/Description	Plug Seq.	Notes
1	VeeT	Transmitter Ground.	1	5
2	Tx_Fault	Transmitter Fault Indication.	3	1
3	Tx_Disable	Transmitter Disable. Module disables on “high” or “open.”	3	2
4	SDA	Module Definition 2. Data Line for Serial ID.	3	
5	SCL	Module Definition 1. Clock Line for Serial ID.	3	
6	MOD_ABS	Module Definition 0.	3	3
7	RS0	Rx Rate Select (LVTTTL). Rate Select 0. Optionally controls SFP28 module receiver. This pin is pulled “low” to VeeT with a >30k resistor.	3	
8	Rx_LOS	Loss of Signal.	3	4
9	RS1	Tx Rate Select (LVTTTL). Rate Select 1. Optionally controls SFP28 module transmitter. This pin is pulled “low” to VeeT with a >30k resistor.	1	
10	VeeR	Receiver Ground.	1	5
11	VeeR	Receiver Ground.	1	5
12	RD-	Inverted Received Data Out.	3	6
13	RD+	Received Data Out.	3	6
14	VeeR	Receiver Ground.	1	5
15	VccR	3.3V ± 5% Receiver Power.	2	7
16	VccT	3.3V ± 5% Transmitter Power.	2	7
17	VeeT	Transmitter Ground.	1	5
18	TD+	Transmit Data In.	3	8
19	TD-	Inverted Transmit Data In.	3	8
20	VeeT	Transmitter Ground.	1	5

Notes

1. Tx_Fault is an open collector/drain output that should be pulled up with a 4.7kΩ to 10kΩ resistor on the host board. Pull-up voltage between 2.4V and VccT/R+0.3V. When “high,” the output indicates a laser fault of some kind. “Low” indicates normal operation. In the “low” state, the output will be pulled to <0.4V.
2. Tx_Disable is an input that is used to shut down the transmitter optical output. It is pulled up within the module with a 4.7kΩ to 10kΩ resistor. Its states are:
 - Low (-0.3V to 0.8V): Transmitter On
 - (>0.8V, <2.0V): Undefined
 - High (2.0V to VccT/R+0.3V): Transmitter Disabled
 - Open: Transmitter Disabled.
3. Modulation Absent. Connected to the VeeT or VeeR in the module.
4. Rx_LOS (Loss of Signal) is an open collector/drain output that should be pulled up with a 4.7kΩ to 10kΩ resistor. Pull-up voltage between 2.4V and VccT/R+0.3V. When “high,” this output indicates that the received optical power is below the worst-case receiver sensitivity (as defined by the standard in use). “Low” indicates normal operation. In the “low” state, the output will be pulled to <0.4V.
5. VeeR and VeeT may be internally connected within the SFP module.
6. RD-/+. These are the differential receiver outputs. They are AC-coupled, 100Ω differential lines which should be terminated with 100Ω (differential) at the user SERDES. The AC coupling is done

inside the module and is thus not required on the host board. The voltage swing on these lines will be between 150mV to 500mV single-ended when properly terminated.

7. VccR and VccT are the receiver and transmitter power supplies. They are defined as 3.3V ±5% at the SFP+ connector pin. Maximum supply current is 360mA. Inductors with DC resistance of less than 1Ω should be used in order to maintain the required voltage at the SFP28 input pin with 3.3V supply voltage. When the recommended supply-filtering network is used, hot-plugging of the SFP28 transceiver module will result in an in-rush current of no more than 30mA greater than the steady state value. VccR and VccT may be internally connected within the SFP28 transceiver module.
8. TD-/+. These are the differential transmitter inputs. They are AC-coupled, differential lines with 100Ω differential termination inside the module. The AC coupling is done inside the module and is thus not required on the host board. The inputs will accept swings of 100mV to 450mV single-ended, though it is recommended values that is less than 900mV differential swing be used for best EMI performance.

Pin-Out Details

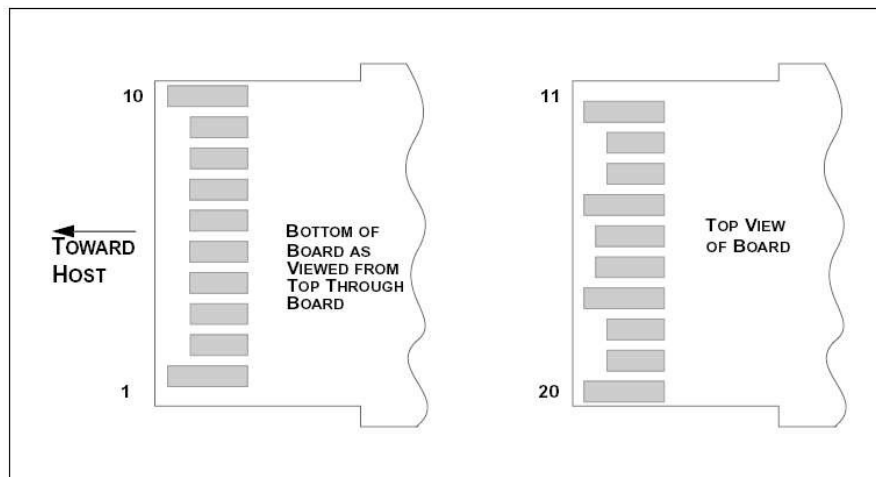
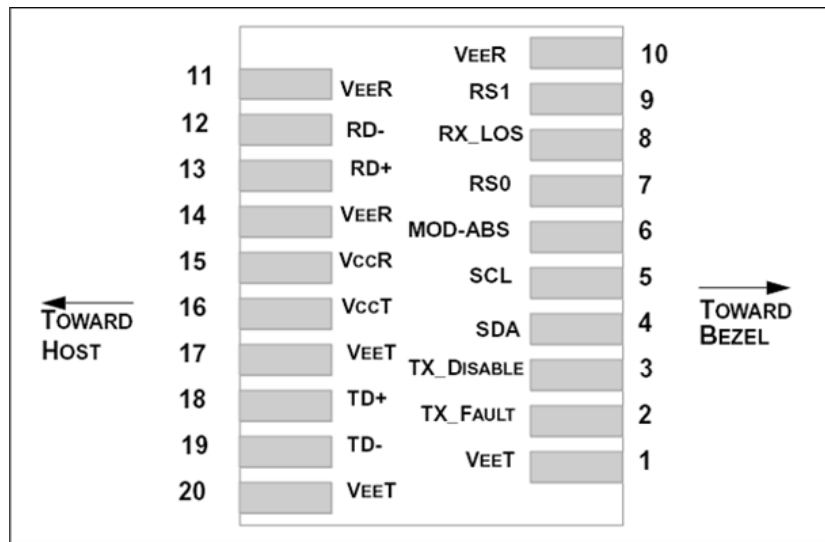

Mechanical Specifications

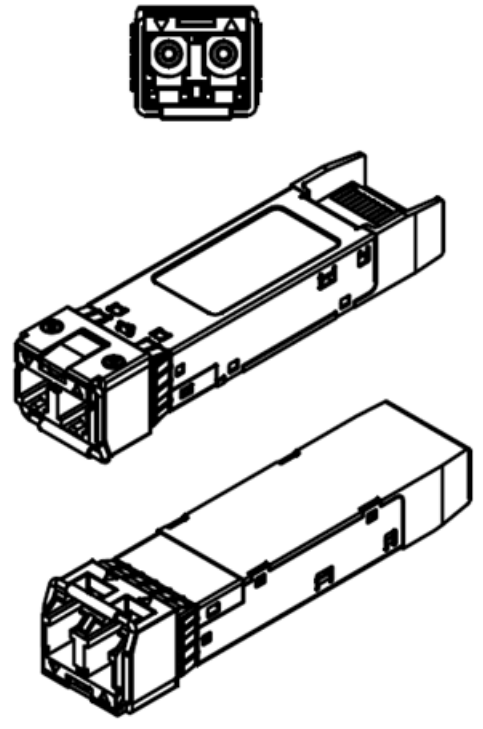
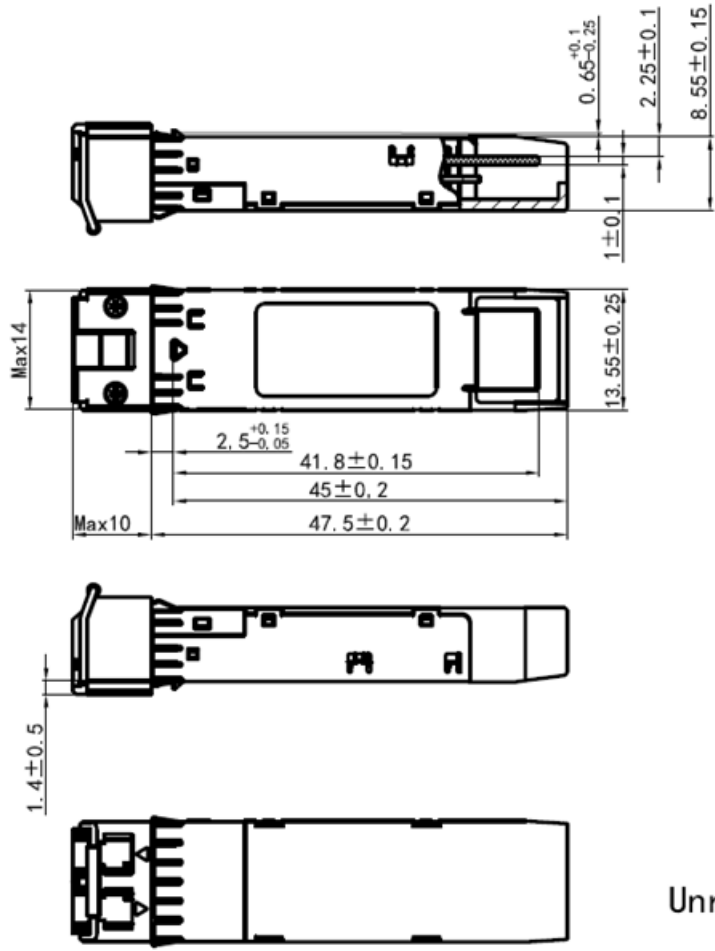

Unremarked tolerances $\pm 0.2\text{mm}$

About AddOn Networks

In 1999, AddOn Networks entered the market with a single product. Our founders fulfilled a severe shortage for compatible, cost-effective optical transceivers that compete at the same performance levels as leading OEM manufacturers. Adhering to the idea of redefining service and product quality not previously had in the fiber optic networking industry, AddOn invested resources in solution design, production, fulfillment, and global support.

Combining one of the most extensive and stringent testing processes in the industry, an exceptional free tech support center, and a consistent roll-out of innovative technologies, AddOn has continually set industry standards of quality and reliability throughout its history.

Reliability is the cornerstone of any optical fiber network and is ingrained in AddOn's DNA. It has played a key role in nurturing the long-term relationships developed over the years with customers. AddOn remains committed to exceeding industry standards with certifications ranging from NEBS Level 3 to ISO 9001:2015 with every new development while maintaining the signature reliability of its products.



U.S. Headquarters

Email: sales@addonnetworks.com

Telephone: +1 877.292.1701

Fax: 949.266.9273

Europe Headquarters

Email: salesemea@addonnetworks.com

Telephone: +44 1285 842070