

QSFP28-100GB-PSM4-2-C-C

Cisco® Compatible TAA 100GBase-PSM4 QSFP28 Transceiver (SMF, 1310nm, 2km, MPO, DOM)

Features:

- SFF-8665 Compliance
- MPO Connector
- Single-mode Fiber
- Commercial Temperature 0 to 70 Celsius
- Hot Pluggable
- Metal with Lower EMI
- Excellent ESD Protection
- RoHS Compliant and Lead Free

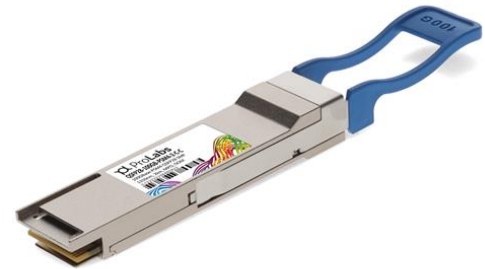

Applications:

- 100GBase Ethernet
- Access and Enterprise

Product Description

This Cisco® compatible QSFP28 transceiver provides 100GBase-PSM4 throughput up to 2km over single-mode fiber (SMF) using a wavelength of 1310nm via an MPO connector. It is guaranteed to be 100% compatible with the equivalent Cisco® transceiver. This easy to install, hot swappable transceiver has been programmed, uniquely serialized and data-traffic and application tested to ensure that it will initialize and perform identically. Digital optical monitoring (DOM) support is also present to allow access to real-time operating parameters. This transceiver is Trade Agreements Act (TAA) compliant. We stand behind the quality of our products and proudly offer a limited lifetime warranty.

ProLabs' transceivers are RoHS compliant and lead-free.

TAA refers to the Trade Agreements Act (19 U.S.C. & 2501-2581), which is intended to foster fair and open international trade. TAA requires that the U.S. Government may acquire only "U.S.-made or designated country end products."



Absolute Maximum Ratings

Parameter	Symbol	Min.	Typ.	Max.	Unit
Maximum Supply Voltage	Vcc	-0.5		3.6	V
Storage Temperature	TS	-40		85	°C
Operating Case Temperature	Tc	0		70	°C
Relative Humidity (non-condensation)	RH	0		85	%
Data Rate, each Lane			25.78125		Gbps
Damage Threshold, each Lane	THd	3.0			dBm
Data Rate Accuracy		-100		100	ppm
Link Distance with G.652	D	0.002		2	km

Electrical Characteristics

Parameter	Test Point	Min.	Typ.	Max.	Unit	Notes
Power Supply Voltage	Vcc	3.135	3.30	3.465	V	
Power Supply Current	Icc			1.06	A	
Power Consumption				3.5	W	
Control Input Voltage High		2		Vcc	V	
Control Input Voltage Low		0		0.8	V	
Transmitter (each Lane)						
Overload Differential Voltage pk-pk	TP1a	900			mV	
Common Mode Voltage (Vcm)	TP1	-350		2850	mV	1
Differential Termination Resistance Mismatch	TP1			10	%	At 1MHz
Differential Return Loss (SDD11)	TP1			See CEI- 28G-VSR Equation 13-19	dB	
Common Mode to Differential conversion and Differential to Common Mode conversion (SDC11, SCD11)	TP1			See CEI- 28G-VSR Equation 13-20	dB	
Stressed Input Test	TP1a	See CEI- 28G-VSR Section 13.3.11.2.1				
Receiver (each Lane)						
Differential Voltage, pk-pk	TP4			900	mV	
Common Mode Voltage (Vcm)	TP4	-350		2850	mV	1
Common Mode Noise, RMS	TP4			17.5	mV	
Differential Termination Resistance Mismatch	TP4			10	%	At 1MHz
Differential Return Loss (SDD22)	TP4			See CEI- 28G-VSR Equation 13-19	dB	
Common Mode to Differential conversion and Differential to Common Mode conversion (SDC22, SCD22)	TP4			See CEI- 28G-VSR Equation 13-21	dB	
Common Mode Return Loss (SCC22)	TP4			-2	dB	2
Transition Time, 20 to 80%	TP4	9.5			ps	
Vertical Eye Closure (VEC)	TP4			5.5	dB	
Eye Width at 10 ⁻¹⁵ probability (EW15)	TP4	0.57			UI	
Eye Height at 10 ⁻¹⁵ probability (EH15)	TP4	228			mV	

Notes:

1. Vcm is generated by the host. Specification includes effects of ground offset voltage.
2. From 250MHz to 30GHz.

Optical Characteristics

Parameter	Symbol	Min.	Typ.	Max.	Unit	Notes
Transmitter						
Center Wavelength	λ_c	1295	1310	1325	nm	1
Side Mode Suppression Ratio	SMSR	30			dB	
Total Average Launch Power	P_T			8.0	dBm	
Average Launch Power, each Lane	P_{AVG}	-5.5		2.0	dBm	2
Optical Modulation Amplitude (OMA), each Lane	P_{OMA}	-3.5		2.2	dBm	1
Launch Power in OMA minus Transmitter and Dispersion Penalty (TDP), each Lane		-4.3			dBm	
TDP, each Lane	TDP			2.9	dB	
Extinction Ratio	ER	3.5			dB	
Optical Return Loss Tolerance	TOL			20	dB	
Transmitter Reflectance	R_T			-12	dB	
Average Launch Power OFF Transmitter, each Lane	P_{off}			-30	dBm	
Transmitter Eye Mask Definition {X1, X2, X3, Y1, Y2, Y3}		{0.31,0.4,0.45,0.34,0.38,0.4}				
Receiver						
Center Wavelength	λ_c	1295	1310	1325	nm	
Damage Threshold, each Lane	TH_d	3.0			dBm	2
Average Receive Power, each Lane		-10.2		2.0	dBm	
Receive Power (OMA), each Lane				2.2	dBm	
Receiver Sensitivity (OMA), each Lane	SEN1			-9.0	dBm	for BER = 1×10^{-12}
Stressed Receiver Sensitivity (OMA), each Lane				-6.44	dBm	for BER = 1×10^{-12}
Receiver Sensitivity (OMA), each Lane	SEN2			-11.35	dBm	for BER = 5×10^{-5}
Stressed Receiver Sensitivity (OMA), each Lane				-8.79	dBm	for BER = 5×10^{-5}
Receiver Reflectance	R_R			-26	dB	
LOS Assert	LOSA	-30			dBm	
LOS Deassert	LOSD			-15	dBm	
LOS Hysteresis	LOSH	0.5			dB	
Receiver Electrical 3 dB upper Cutoff Frequency, each Lane	F_c			31	GHz	
Conditions of Stress Receiver Sensitivity Test (Note 3)						
Vertical Eye Closure Penalty, each Lane			1.9		dB	
Stressed Eye J2 Jitter, each Lane			0.27		UI	
Stressed Eye J4 Jitter, each Lane			0.39		UI	
Stressed Eye Mask Definition {X1, X2, X3, Y1, Y2, Y3}		{0.24, 0.5, 0.5, 0.24, 0.24, 0.4}				

Notes:

1. Even if the TDP < 0.8 dB, the OMA min must exceed the minimum value specified here.
2. The receiver shall be able to tolerate, without damage, continuous exposure to a modulated optical input signal having this power level on one lane. The receiver does not have to operate correctly at this input power.
3. Vertical eye closure penalty, stressed eye J2 jitter, stressed eye J4 jitter, and stressed receiver eye mask definition are test conditions for measuring stressed receiver sensitivity. They are not characteristics of the receiver.

Electrical Pin-out Details

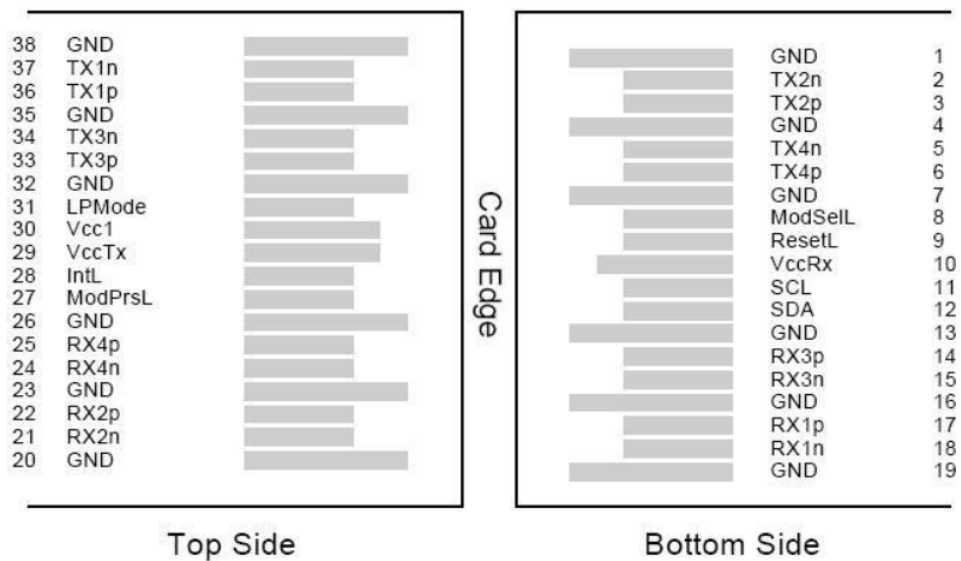

Pin Descriptions

Pin	Logic	Symbol	Name/Descriptions	Notes
1		GND	Ground	1
2	CML-I	Tx2n	Transmitter Inverted Data Input	
3	CML-I	Tx2p	Transmitter Non-Inverted Data output	
4		GND	Ground	1
5	CML-I	Tx4n	Transmitter Inverted Data Input	
6	CML-I	Tx4p	Transmitter Non-Inverted Data output	
7		GND	Ground	1
8	LVTLL-I	ModSelL	Module Select	
9	LVTLL-I	ResetL	Module Reset	
10		VccRx	+3.3V Power Supply Receiver	2
11	LVC MOS-I/O	SCL	2-Wire Serial Interface Clock	
12	LVC MOS-I/O	SDA	2-Wire Serial Interface Data	
13		GND	Ground	
14	CML-O	Rx3p	Receiver Non-Inverted Data Output	
15	CML-O	Rx3n	Receiver Inverted Data Output	
16		GND	Ground	1
17	CML-O	Rx1p	Receiver Non-Inverted Data Output	
18	CML-O	Rx1n	Receiver Inverted Data Output	
19		GND	Ground	1
20		GND	Ground	1
21	CML-O	Rx2n	Receiver Inverted Data Output	
22	CML-O	Rx2p	Receiver Non-Inverted Data Output	
23		GND	Ground	1
24	CML-O	Rx4n	Receiver Inverted Data Output	1
25	CML-O	Rx4p	Receiver Non-Inverted Data Output	
26		GND	Ground	1
27	LVTTL-O	ModPrsL	Module Present	
28	LVTTL-O	IntL	Interrupt	
29		VccTx	+3.3 V Power Supply transmitter	2
30		Vcc1	+3.3 V Power Supply	2
31	LVTTL-I	LPMode	Low Power Mode	
32		GND	Ground	1
33	CML-I	Tx3p	Transmitter Non-Inverted Data Input	
34	CML-I	Tx3n	Transmitter Inverted Data Output	
35		GND	Ground	1
36	CML-I	Tx1p	Transmitter Non-Inverted Data Input	
37	CML-I	Tx1n	Transmitter Inverted Data Output	
38		GND	Ground	1

Notes:

- 1. The module signal grounds are isolated from the module case.
- 2. This is an open collector/drain output that on the host board requires a 4.7KΩ to 10KΩ pull-up resistor to VccHost.

Recommended Host Board Power Supply Filter Network

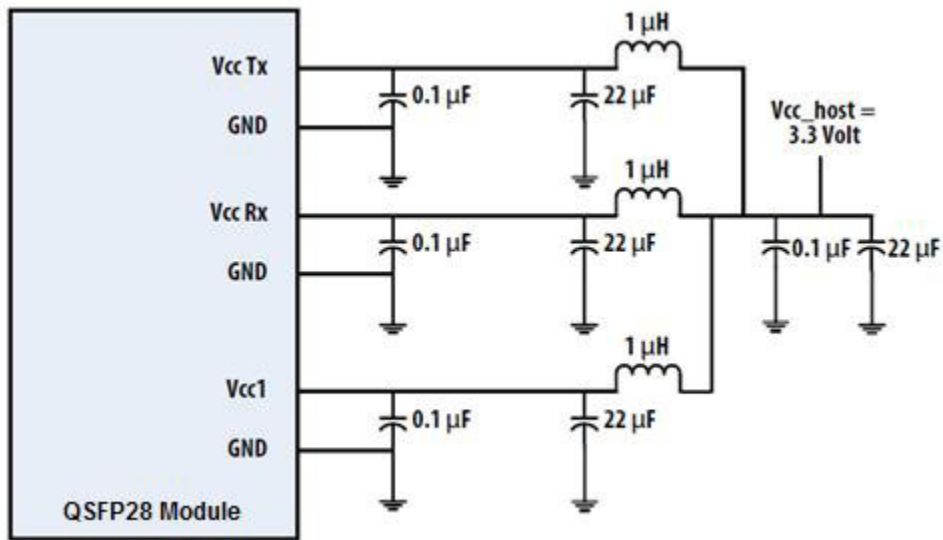

Transceiver Block Diagram

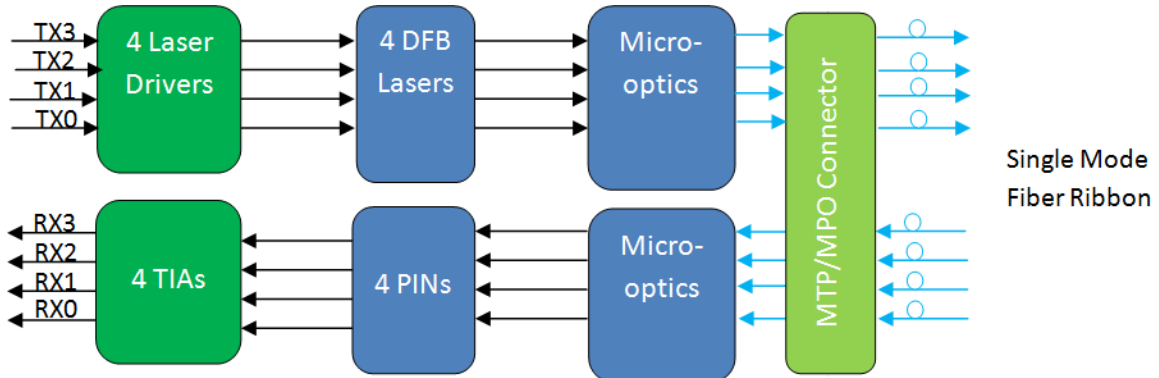

Digital Diagnostic Functions

The following digital diagnostic characteristics are defined over the normal operating conditions unless otherwise specified.

Parameter	Symbol	Min	Max	Units	Notes
Temperature monitor absolute error	DMI_Temp	-3	3	degC	Over operating temperature range
Supply voltage monitor absolute error	DMI_VCC	-0.1	0.1	V	Over full operating range
Channel RX power monitor absolute error	DMI_RX_Ch	-2	2	dB	1
Channel Bias current monitor	DMI_Ibias_Ch	-10%	10%	mA	
Channel TX power monitor absolute error	DMI_TX_Ch	-2	2	dB	1

Mechanical Specifications

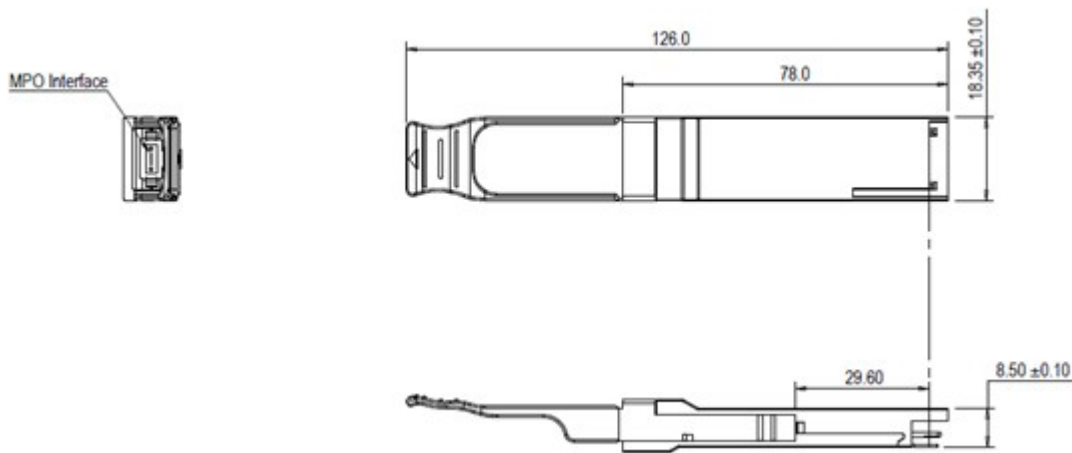

Attention: To minimize MPO connection induced reflections, an MPO receptacle with 8-degree angled end-face is utilized for this product. A female MPO connector with 8-degree end-face should be used with this product as illustrated in below Figure.

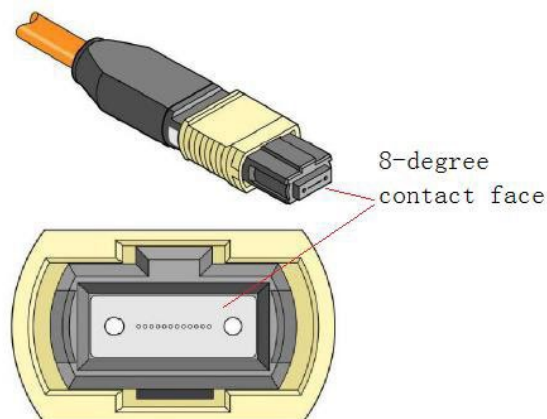

About ProLabs

Our extensive experience comes as standard. For over 20 years ProLabs has delivered optical connectivity solutions that give our customers freedom and choice through our ability to provide seamless interoperability. At the heart of our company is the ability to provide state-of-the-art optical transport and connectivity solutions that are compatible with more than 100 optical switching and transport platforms.

A Complete Portfolio of Network Solutions

ProLabs is focused on innovations in optical transport and connectivity. The combination of our knowledge of optics and networking equipment enables ProLabs to be your single source for optical transport and connectivity solutions from 100Mb to 1.6T while providing innovative solutions that increase network efficiency. We provide the optical connectivity expertise that is compatible with and enhances your switching and transport equipment.

The Trusted Partner

Customer service is our number one value. ProLabs has invested in people, labs and manufacturing capacity to ensure compatible products, and immediate answers to your questions. With Engineering and Manufacturing offices in the U.K. and U.S. augmented by field offices throughout the U.S., U.K. and Asia, ProLabs is able to be our customers best advocate 24 hours a day.



Contact Information

ProLabs US

Email: sales@prolabs.com

Telephone: 952-852-0252

ProLabs UK

Email: salessupport@prolabs.com

Telephone: +44 1285 719 600