

## QSFP28-100GB-BX-D-80-CN2-AO

Ciena® Compatible TAA 100GBase-ZR4 BX QSFP28 Transceiver (SMF, 1310.19nmTx/1272.55nmRx, 80km, LC, DOM)

### Features

- QSFP28 MSA Compliant
- Built-In 4-Channel CDR
- Hot-Pluggable
- Supports 103.1Gbps to 112.2Gbps OTU4
- LAN WDM EML Laser and PIN Receiver with SOA
- Excellent EMI Performance
- Single 3.3V Power Supply
- Up to 80km Reach for G.652 SMF
- Single LC Receptacle
- Power Consumption: 5.5W
- Operating Temperature: 0 to 70 Celsius
- RoHS Compliant and Lead-Free



### Applications

- InfiniBand QDR and DDR
- 100GBase Ethernet

### Product Description

This Ciena® compatible QSFP28 transceiver provides 100GBase-BX ZR4 throughput up to 80km over single-mode fiber (SMF) using a wavelength of 1310.19nmTx/1272.55nmRx via an LC connector. This bidirectional unit must be used with another transceiver or network appliance of complementing wavelengths. It can operate at temperatures between 0 and 70C. Our transceiver is built to meet or exceed OEM specifications and is guaranteed to be 100% compatible with Ciena®. It has been programmed, uniquely serialized, and tested for data-traffic and application to ensure that it will initialize and perform identically. All of our transceivers comply with Multi-Source Agreement (MSA) standards to provide seamless network integration. Additional product features include Digital Optical Monitoring (DOM) support which allows access to real-time operating parameters. We stand behind the quality of our products and proudly offer a limited lifetime warranty.

AddOn's transceivers are RoHS compliant and lead-free.

TAA refers to the Trade Agreements Act (19 U.S.C. & 2501-2581), which is intended to foster fair and open international trade. TAA requires that the U.S. Government may acquire only "U.S.-made or designated country end products."



## Absolute Maximum Ratings

Parameter	Symbol	Min.	Typ.	Max.	Unit	Notes
Storage Temperature	Tstg	-40		85	°C	
Operating Case Temperature	Tc	0		70	°C	
Relative Humidity (Non-Condensing)	RH	15		85	%	
Supply Voltage	Vcc	-0.3		4.0	V	
Damage Threshold	THd	6.5			dBm	
Data Rate Per Lane			25.78125	28.05	Gbps	
Power Consumption	P			5.5	W	
Link Distance (SMF)	D			80	km	1

### Notes:

1. Depends on actual fiber loss/km (link distance specified is for a fiber insertion loss of 0.35dB/km).

## Electrical Characteristics

Parameter	Symbol	Min.	Typ.	Max.	Unit	Notes
Power Supply Voltage	Vcc	3.135	3.3	3.465	V	
Power Supply Current	Icc			1585	mA	
Control Input Voltage - High		2		Vcc	V	
Control Input Voltage - Low		0		0.8	V	
<b>Transmitter Per Lane</b>						
Input Differential Impedance	RIN		100		Ω	
Differential Termination Mismatch				10	%	
Differential Data Input Amplitude	VIN,pp	180		1000	mV	
LPMODE, Reset, and ModSelL	VIL	-0.3		0.8	V	
	VIH	2		Vcc+0.3	V	
<b>Receiver</b>						
Differential Data Output Amplitude	VOUT,pp	350		900	mV	
Differential Termination Mismatch				10	%	
Transition Time (20-80%)		9.5			ps	
ModPrsL and IntL	VOL	0		0.4	V	
	VOH	Vcc-0.5		Vcc+0.3	V	

## Optical Characteristics

Parameter	Symbol	Min.	Typ.	Max.	Unit	Notes
<b>Transmitter</b>						
<b>Center Wavelength</b>	$\lambda_C$	1294.53	1295.56	1296.59	nm	
		1299.02	1300.05	1301.09		
		1303.54	1304.58	1305.63		
		1308.09	1309.14	1310.19		
<b>Side-Mode Suppression Ratio</b>	SMSR	30				
<b>Total Average Power</b>	Pt	8.0		10.5	dBm	
<b>Average Launch Power Per Lane</b>	Pavg	2.0		4.5	dBm	
<b>Extinction Ratio</b>	ER	6			dB	
<b>Difference in Launch Power Between Any Two Lanes (OMA)</b>				3.6	dB	
<b>Average Launch Power of Off Transmitter Per Lane</b>	Poff			-30	dBm	
<b>Transmitter Reflectance</b>				-12	dB	
<b>RIN<sub>20OMA</sub></b>	RIN			-130	dB/Hz	
<b>Optical Return Loss Tolerance</b>	TOL			20	dB	
<b>Transmitter Eye Mask: {X1, X2, X3, Y1, Y2, Y3}</b>		{0.25, 0.4, 0.45, 0.25, 0.28, 0.4}				
<b>Receiver</b>						
<b>Center Wavelength</b>	$\lambda_C$	1272.55	1273.55	1274.54	nm	
		1276.89	1277.89	1278.89		
		1281.25	1282.26	1283.27		
		1285.65	1286.66	1287.68		
<b>Average Receive Power Per Lane</b>	Pin	-30		-7	dBm	
<b>Receive Power on OMA Per Lane</b>	PinOMA			-7	dBm	
<b>Receiver Reflectance</b>	dB			-26	dB	
<b>Average Receiver Sensitivity</b>	SEN1			-22	dBm	1
	SEN2			-21	dBm	2
	SEN3			-28	dBm	3
	SEN4			-27	dBm	4
<b>LOS Assert</b>	LOSA	-40			dBm	
<b>LOS De-Assert</b>	LOSD			-29	dBm	
<b>LOS Hysteresis</b>	LOSH	0.5			dB	

### Notes:

1. Measured @25.78125Gbps, ER=8.2dB, BER=<1E<sup>-12</sup>, PRBS=2<sup>31</sup>-1 NRZ.
2. Measured @28.05Gbps, ER=8.2dB, BER=<1E<sup>-12</sup>, PRBS=2<sup>31</sup>-1 NRZ.
3. Measured @25.78125Gbps, ER=8.2dB, BER=<5E<sup>-5</sup>, PRBS=2<sup>31</sup>-1 NRZ.
4. Measured @28.05Gbps, ER=8.2dB, BER=<5E<sup>-5</sup>, PRBS=2<sup>31</sup>-1 NRZ.

## Pin Descriptions

Pin	Symbol	Name/Description	Notes
1	GND	Transmitter Ground. (Common with Receiver Ground).	1
2	Tx2-	Transmitter Inverted Data Input.	
3	Tx2+	Transmitter Non-Inverted Data Output.	
4	GND	Transmitter Ground. (Common with Receiver Ground).	1
5	Tx4-	Transmitter Inverted Data Input.	
6	Tx4+	Transmitter Non-Inverted Data Output.	
7	GND	Transmitter Ground. (Common with Receiver Ground).	1
8	ModSelL	Module Select.	
9	ResetL	Module Reset.	
10	VccRx	+3.3V Receiver Power Supply.	2
11	SCL	2-Wire Serial Interface Clock.	
12	SDA	2-Wire Serial Interface Data.	
13	GND	Transmitter Ground. (Common with Receiver Ground).	1
14	Rx3+	Receiver Non-Inverted Data Output.	
15	Rx3-	Receiver Inverted Data Output.	
16	GND	Transmitter Ground. (Common with Receiver Ground).	1
17	Rx1+	Receiver Non-Inverted Data Output.	
18	Rx1-	Receiver Inverted Data Output.	
19	GND	Transmitter Ground. (Common with Receiver Ground).	1
20	GND	Transmitter Ground. (Common with Receiver Ground).	1
21	Rx2-	Receiver Inverted Data Output.	
22	Rx2+	Receiver Non-Inverted Data Output.	
23	GND	Transmitter Ground. (Common with Receiver Ground).	1
24	Rx4-	Receiver Inverted Data Output.	
25	Rx4+	Receiver Non-Inverted Data Output.	
26	GND	Transmitter Ground. (Common with Receiver Ground).	1
27	ModPrsL	Module Present.	
28	IntL	Interrupt.	
29	VccTx	+3.3V Transmitter Power Supply.	2
30	Vcc1	+3.3V Power Supply.	2
31	LPMODE	Low-Power Mode.	
32	GND	Transmitter Ground. (Common with Receiver Ground).	1
33	Tx3+	Transmitter Non-Inverted Data Input.	
34	Tx3-	Transmitter Inverted Data Output.	
35	GND	Transmitter Ground. (Common with Receiver Ground).	1



# Mechanical Specifications

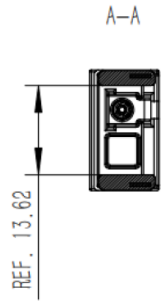
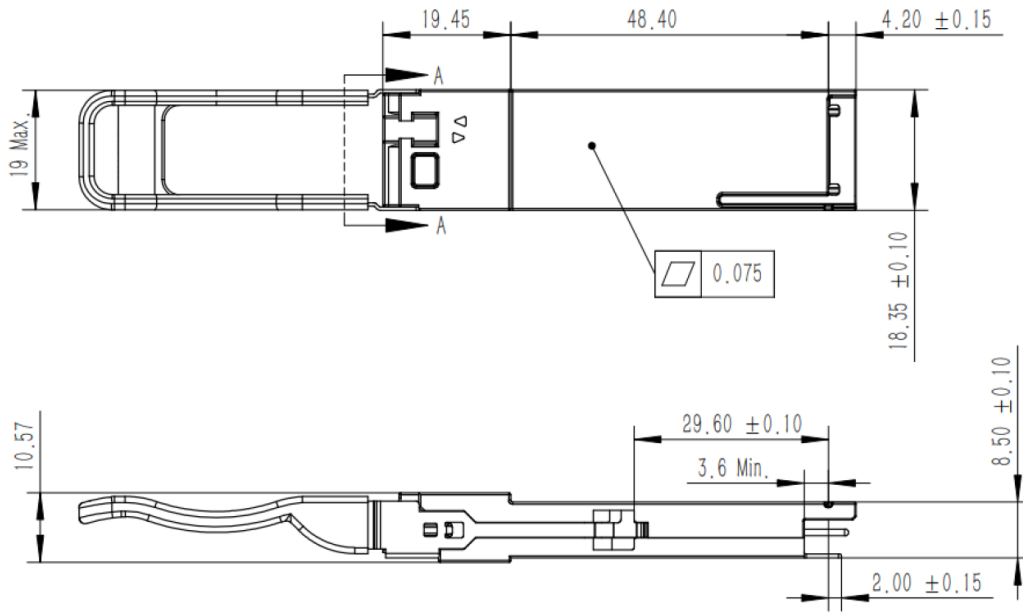

Units in mm

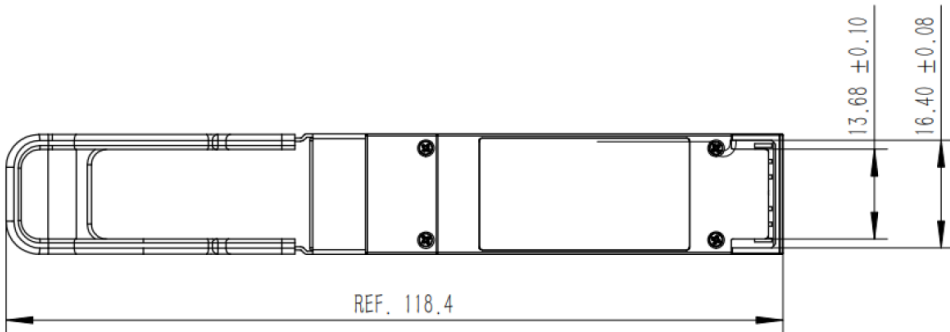

## About AddOn Networks

In 1999, AddOn Networks entered the market with a single product. Our founders fulfilled a severe shortage for compatible, cost-effective optical transceivers that compete at the same performance levels as leading OEM manufacturers. Adhering to the idea of redefining service and product quality not previously had in the fiber optic networking industry, AddOn invested resources in solution design, production, fulfillment, and global support.

Combining one of the most extensive and stringent testing processes in the industry, an exceptional free tech support center, and a consistent roll-out of innovative technologies, AddOn has continually set industry standards of quality and reliability throughout its history.

Reliability is the cornerstone of any optical fiber network and is ingrained in AddOn's DNA. It has played a key role in nurturing the long-term relationships developed over the years with customers. AddOn remains committed to exceeding industry standards with certifications ranging from NEBS Level 3 to ISO 9001:2015 with every new development while maintaining the signature reliability of its products.



## U.S. Headquarters

Email: [sales@addonnetworks.com](mailto:sales@addonnetworks.com)

Telephone: +1 877.292.1701

Fax: 949.266.9273

## Europe Headquarters

Email: [salesemea@addonnetworks.com](mailto:salesemea@addonnetworks.com)

Telephone: +44 1285 842070