

QSFP112-400GB-LR4-MX-NPC

Mellanox® Compatible TAA 400GBase-LR4 QSFP112 Transceiver (SMF, 1310nm, 10km, LC, CMIS 5.2)

Features:

- Compliant with 400GBASE-LR4
- Up to 10km over SMF with FEC
- Single 3.3V Power Supply
- Compliant with IEEE802ck and IEEE802cu Standards
- Compliant with QSFP-DD MSA
- Duplex LC Connector
- CMIS 5.2
- 4 CWDM EML and PIN Array design
- Class 1 Laser
- Operating Temperature: 0 to 70 Celsius
- RoHS Compliant and Lead-Free

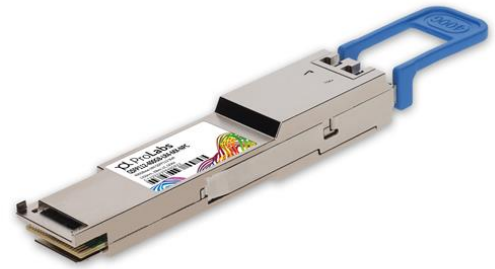

Applications:

- 400GBase Ethernet

Product Description

This Mellanox® compatible QSFP112 transceiver provides 400GBase-LR4 throughput up to 10km over single-mode fiber (SMF) using a wavelength of 1310nm via an LC connector. It is guaranteed to be 100% compatible with the equivalent Mellanox® transceiver. This easy to install, hot swappable transceiver has been programmed, uniquely serialized and data-traffic and application tested to ensure that it will initialize and perform identically. Digital optical monitoring (DOM) support is also present to allow access to real-time operating parameters. This transceiver is Trade Agreements Act (TAA) compliant. We stand behind the quality of our products and proudly offer a limited lifetime warranty.

ProLabs' transceivers are RoHS compliant and lead-free.

TAA refers to the Trade Agreements Act (19 U.S.C. & 2501-2581), which is intended to foster fair and open international trade. TAA requires that the U.S. Government may acquire only "U.S.-made or designated country end products."



Absolute Maximum Ratings

Parameter	Symbol	Min.	Typ.	Max.	Unit	Notes
Storage Temperature	Tstg	-40		85	°C	
Operating Case Temperature	Tc	0		70	°C	
Relative Humidity	RH	5		85	%	
Supply Voltage	Vcc	-0.5		3.6	V	
Signaling Rate Per Lane			53.125 ± 100ppm		Gbd	PAM4
Damage Threshold Per Lane		5			dBm	
Link Distance with G.652	D	0.002		10	km	
Modulation Format		PAM4				

Electrical Characteristics

Parameter	Symbol / Test Point	Min.	Typ.	Max.	Unit	Notes
Power Supply Voltage	Vcc	3.135	3.3	3.465	V	
Power Consumption	PC			10	W	
Transmitter						
Differential Pk-Pk Input Voltage Tolerance	TP1a	750			mV	
AC Common-Mode RMS Voltage Tolerance	TP1a	25			mV	
Single-Ended Voltage Tolerance	TP1a	-0.4		3.3	V	
DC Common-Mode Voltage Tolerance	TP1	-0.35		2.85	V	
Receiver						
AC Common-Mode Output Voltage (RMS)	TP4			25	mV	
Differential Pk-Pk Output Voltage	Short-Mode	TP4		600	mV	
	Long-Mode			845		
Eye Height	TP4	15			mV	
DC Common-Mode Voltage Tolerance	TP4	-0.35		2.85	V	

Optical Characteristics

Parameter	Symbol	Min.	Typ.	Max.	Unit	Notes
Transmitter						
Center Wavelength	λ_C	1264.5	1271	1277.5	nm	
		1284.5	1291	1297.5		
		1304.5	1311	1317.5		
		1324.5	1331	1337.5		
Total Average Launch Power	POUT			11.1	dBm	

Average Launch Power Per Lane		P	-27		5.1	dBm	1
OMA_{outer} Per Lane	TDECQ < 1.4dB	POMA	-0.3		4.4	dBm	
	1.4dB ≤ TDECQ ≤ 3.4dB		-1.1 + TDECQ		4.4		
Difference in Launch Power Between Any Two Lanes (OMA_{outer})		DP			4	dB	
Transmitter and Dispersion Eye Closure for PAM4 (TDECQ) Per Lane		TDECQ			3.4	dB	
Transmitter Eye Closure for PAM4 (TECQ) Per Lane		TECQ			3.4	dB	
 TDECQ - TECQ 					2.5	dB	
Side-Mode Suppression Ratio		SMSR	30			dB	
Extinction Ratio		ER	3.5			dB	
Average Launch Power of Off Transmitter Per Lane		P _{off}			-16	dBm	
RIN_{15.6,OMA}		RIN			-136	dB/Hz	
Optical Return Loss Tolerance		ORLT			15.6	dB	
Transmitter Reflectance		TR			-26	dB	2
Receiver							
Center Wavelength	λ _C	1264.5	1271	1277.5	nm		
		1284.5	1291	1297.5			
		1304.5	1311	1317.5			
		1324.5	1331	1337.5			
Damage Threshold Per Lane			6.1			dBm	3
Average Receive Power Per Lane			9		5.1	dBm	4
Receive Power (OMA_{outer}) Per Lane		ROMA			4.4	dBm	
Difference in Receive Power Between Any Two Lanes (OMA_{outer})					4.3	dB	
Receiver Reflectance					-26	dB	
Receiver Sensitivity (OMA_{outer}) Per Lane		SEN	Max. (-6.8, TECQ - 8.2)			dBm	
LOS Assert			-26			dBm	
LOS De-Assert					-8	dBm	
LOS Hysteresis			0.5			dBm	

Notes:

1. Average launch power, per lane (minimum), is informative and not the principal indicator of signal strength. A transmitter with launch power below this value cannot be compliant; however, a value above this does not ensure compliance.
2. Transmitter reflectance is defined looking into the transmitter.
3. The receiver shall be able to tolerate, without damage, continuous exposure to an optical signal having this average power level.
4. Average receive power, per lane (minimum), is informative and not the principal indicator of signal strength. A received power below this value cannot be compliant; however, a value above this does not ensure compliance.

Pin Descriptions

Pin	Symbol	Logic	Name/Description	Plug Sequence	Notes
1	GND		Module Ground.	1	1
2	Tx2-	CML-I	Transmitter Inverted Data Input.	3	
3	Tx2+	CML-I	Transmitter Non-Inverted Data Input.	3	
4	GND		Module Ground.	1	1
5	Tx4-	CML-I	Transmitter Inverted Data Input.	3	
6	Tx4+	CML-I	Transmitter Non-Inverted Data Input.	3	
7	GND		Module Ground.	1	1
8	ModSelL	LVTTTL-I	Module Select.	3	
9	ResetL	LVTTTL-I	Module Reset.	3	
10	VccRx		+3.3V Receiver Power Supply.	2	2
11	SCL	LVC MOS-I/O	2-Wire Serial Interface Clock.	3	
12	SDA	LVC MOS-I/O	2-Wire Serial Interface Data.	3	
13	GND		Module Ground.	1	1
14	Rx3+	CML-O	Receiver Non-Inverted Data Output.	3	
15	Rx3-	CML-O	Receiver Inverted Data Output.	3	
16	GND		Module Ground.	1	1
17	Rx1+	CML-O	Receiver Non-Inverted Data Output.	3	
18	Rx1-	CML-O	Receiver Inverted Data Output.	3	
19	GND		Module Ground.	1	1
20	GND		Module Ground.	1	1
21	Rx2-	CML-O	Receiver Inverted Data Output.	3	
22	Rx2+	CML-O	Receiver Non-Inverted Data Output.	3	
23	GND		Module Ground.	1	1
24	Rx4-	CML-O	Receiver Inverted Data Output.	3	
25	Rx4+	CML-O	Receiver Non-Inverted Data Output.	3	
26	GND		Module Ground.	1	1
27	ModPrsL	LVTTTL- O	Module Present.	3	
28	IntL/RxLOS	LVTTTL- O	Interrupt/Optional RxLOS.	3	
29	VccTx		+3.3V Transmitter Power Supply.	2	2
30	Vcc1		+3.3V Power Supply.	2	2
31	LPMMode/TxDis	LVTTTL- I	Low-Power Mode/Optional Tx_Disable.	3	
32	GND		Module Ground.	1	1
33	Tx1+	CML-I	Transmitter Non-Inverted Data Input.	3	
34	Tx1-	CML-I	Transmitter Inverted Data Input.	3	
35	GND		Module Ground.	1	1

36	Tx1+	CML-I	Transmitter Non-Inverted Data.	3	
37	Tx1-	CML-I	Transmitter Inverted Data Input.	3	
38	GND		Module Ground.	1	1

Notes:

1. GND is the symbol for signal and supply (power) common for the QSFP112 module. All are common within the QSFP112 module, and all voltages are referenced to this potential unless otherwise noted. Connect these directly to the host board signal common ground plane.
2. VccRx, Vcc1, and VccTx are the receiver and transmitter power supplies and shall be applied concurrently. VccRx, Vcc1, and VccTx may be internally connected within the QSFP112 module in any combination. The connector pins are each rated for a maximum current of 1.5A (maximum current of 2.0A is required for a high module power of 15-20W).

Pin-Out Details

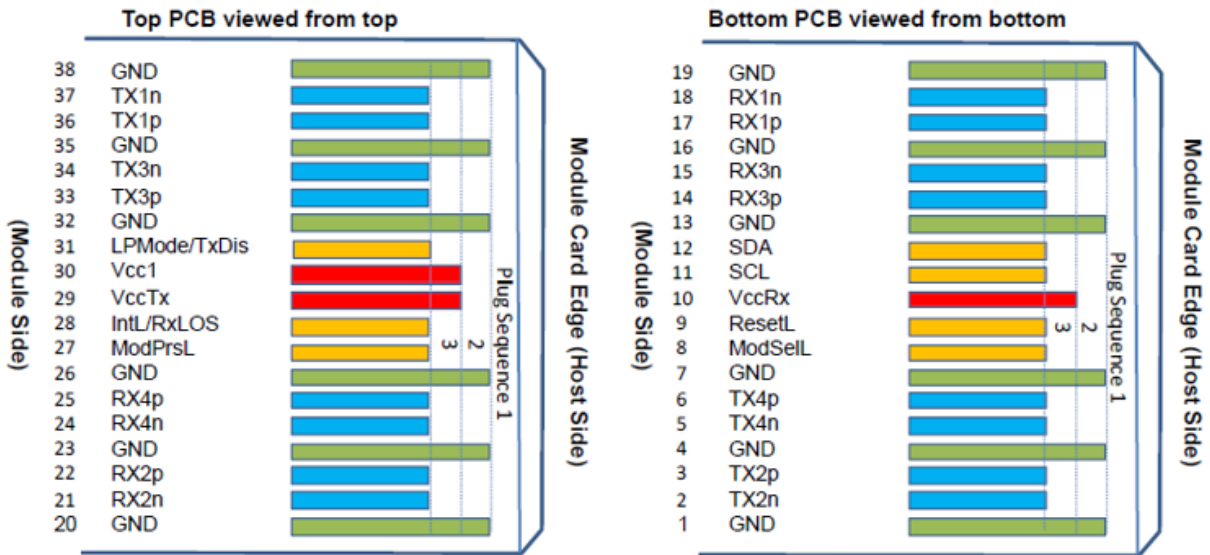

Recommended Host Board Schematic

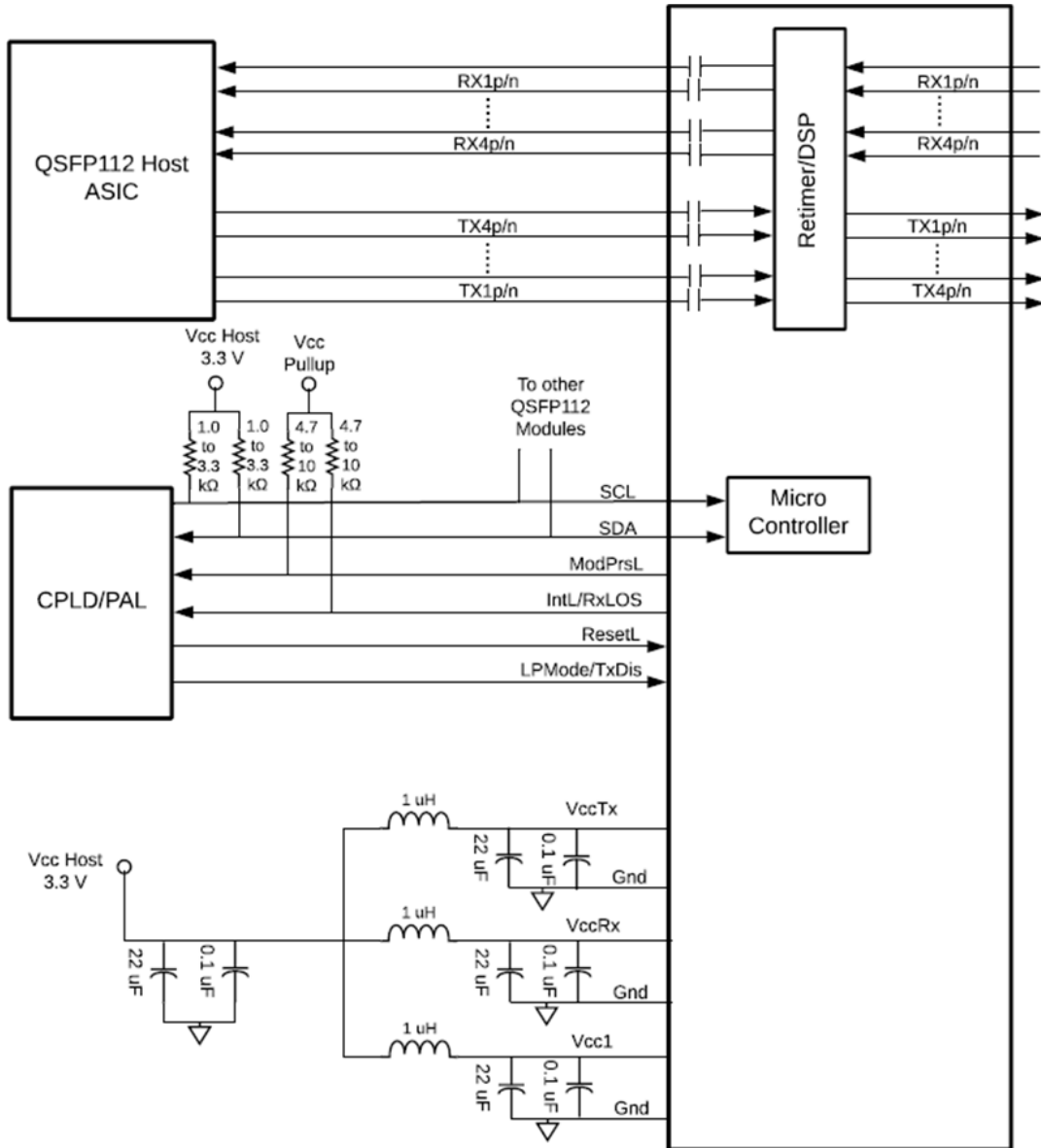

Mechanical Specifications

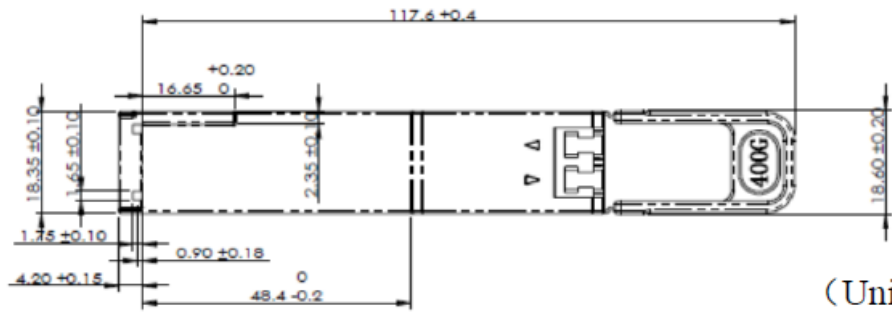
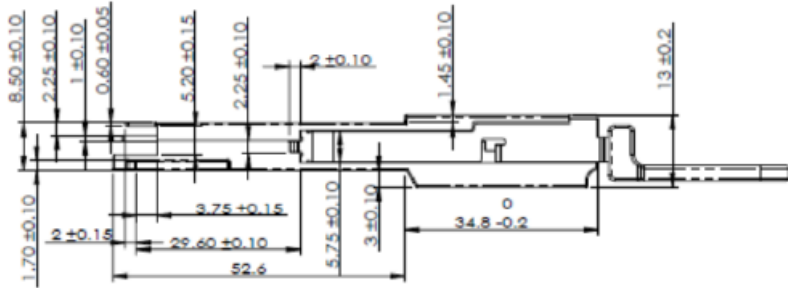
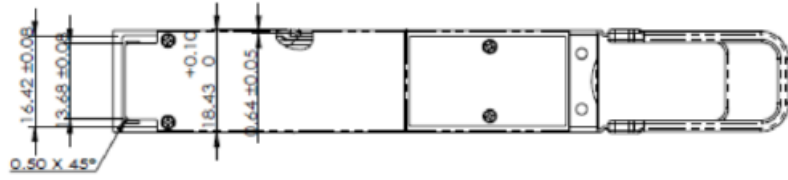

(Unit: mm)

About ProLabs

Our extensive experience comes as standard. For over 20 years ProLabs has delivered optical connectivity solutions that give our customers freedom and choice through our ability to provide seamless interoperability. At the heart of our company is the ability to provide state-of-the-art optical transport and connectivity solutions that are compatible with more than 100 optical switching and transport platforms.

A Complete Portfolio of Network Solutions

ProLabs is focused on innovations in optical transport and connectivity. The combination of our knowledge of optics and networking equipment enables ProLabs to be your single source for optical transport and connectivity solutions from 100Mb to 1.6T while providing innovative solutions that increase network efficiency. We provide the optical connectivity expertise that is compatible with and enhances your switching and transport equipment.

The Trusted Partner

Customer service is our number one value. ProLabs has invested in people, labs and manufacturing capacity to ensure compatible products, and immediate answers to your questions. With Engineering and Manufacturing offices in the U.K. and U.S. augmented by field offices throughout the U.S., U.K. and Asia, ProLabs is able to be our customers best advocate 24 hours a day.



Contact Information

ProLabs US

Email: sales@prolabs.com

Telephone: 952-852-0252

ProLabs UK

Email: salessupport@prolabs.com

Telephone: +44 1285 719 600