

## OSFP-800GB-2XDR4-MX-C

Mellanox® Compatible TAA 800GBase-2xDR4 PAM4 OSFP Transceiver (SMF, 1310nm, 500m, 2xMPO, DOM, CMIS 5.0)

### Features:

- OSFP MSA Compliant
- Supports Both Ethernet and InfiniBand NDR
- Compliant with IEEE 802.3cu-2021: 8x100GBASE-DR Optical Interface
- Compliant with IEEE 802.3ck-2022: 8x100GAUI-1 C2M Electrical Interface
- Supports 850Gbps
- EML Transmitter and PIN PD Receiver
- Compliant with CMIS 5.0
- Operating Temperature: 0 to 70 Celsius
- Dual MPO-12 Connector APC
- Class 1 Laser
- RoHS Compliant and Lead-Free



### Applications:

- 800GBase Ethernet

### Product Description

This Mellanox® compatible OSFP transceiver provides 800GBase-2xDR4 throughput up to 500m over single-mode fiber (SMF) PAM4 using a wavelength of 1310nm via a 2xMPO connector. It can operate at temperatures between 0 and 70C. All of our transceivers are built to comply with Multi-Source Agreement (MSA) standards and are uniquely serialized and tested for data-traffic and application to ensure seamless network integration. Additional product features include Digital Optical Monitoring (DOM) support which allows access to real-time operating parameters. This transceiver is Trade Agreements Act (TAA) compliant. We stand behind the quality of our products and proudly offer a limited lifetime warranty.

ProLabs' transceivers are RoHS compliant and lead-free.

TAA refers to the Trade Agreements Act (19 U.S.C. & 2501-2581), which is intended to foster fair and open international trade. TAA requires that the U.S. Government may acquire only "U.S.-made or designated country end products."



## Absolute Maximum Ratings

Parameter	Symbol	Min.	Typ.	Max.	Unit	Notes
Storage Temperature	Tstg	-40		85	°C	
Operating Case Temperature	Tc	0		70	°C	
Power Supply Voltage	Vcc	-0.5		3.6	V	
Relative Humidity (Non-Condensing)	RH	5		95	%	
Data Input Voltage Differential	V <sub>DIP-V<sub>DIN</sub></sub>			1	V	
Control Input Voltage	V <sub>I</sub>	-0.3		Vcc+0.5	V	
Control Output Current	I <sub>O</sub>	-20		20	mA	
Signaling Speed Per Lane	DRL		53.125		GBd	
Operating Distance		2		500	m	
Data Rate	DR		850		Gbps	

## Electrical Characteristics

Parameter	Symbol	Min.	Typ.	Max.	Unit	Notes
Power Supply Voltage	Vcc	3.135	3.3	3.465	V	
Instantaneous Peak Current at Hot Plug	I <sub>CC_IP</sub>			6600	mA	
Sustained Peak Current at Hot Plug	I <sub>CC_SP</sub>			5494.5	mA	
Maximum Power Dissipation	PD			16.5	W	
Maximum Power Dissipation (Low-Power Mode)	PD <sub>LP</sub>			2	W	
Control Input Voltage - High	V <sub>IH</sub>	Vcc*0.7		Vcc+0.3	V	
Control Input Voltage – Low	V <sub>IL</sub>	-0.3		Vcc*0.3	V	
2-Wire Serial Interface Clock Rate				400	kHz	
Power Supply Noise (1kHz to 1MHz, Pk-Pk)				66	mVp-p	
<b>Transmitter (TP1)</b>						
Differential Pk-Pk Input Voltage Tolerance		750			mV	
Pk-Pk AC Common-Mode Voltage Tolerance	Low-Frequency (VCM <sub>LF</sub> )			32	mV	
	Full-Band (VCM <sub>FB</sub> )			80	mV	
Differential-Mode to Common-Mode Return Loss			802.3ck 120G-2		dB	
Effective Return Loss	ERL	8.5			dB	
Differential Termination Mismatch				10	%	
Single-Ended Voltage Tolerance Range		-0.4		3.3	V	
DC Common-Mode Voltage Tolerance		-0.35		2.85	V	
<b>Receiver (TP4)</b>						
Pk-Pk AC Common-Mode Voltage	Low-Frequency (VCM <sub>LF</sub> )			32	mV	
	Full-Band (VCM <sub>FB</sub> )			80	mV	
Differential Pk-Pk	Short-Mode			600	mV	

Output Voltage	Long-Mode				845	mV	
Eye Height		EH	15			mV	
Vertical Eye Closure		VEC			12	dB	
Common-Mode to Differential-Mode Return Loss		RLDc	802.3ck 120G-1				dB
Effective Return Loss		ERL	8.5			dB	
Differential Termination Mismatch					10	%	
Transition Time			8.5			ps	
DC Common-Mode Voltage Tolerance			-0.35		2.85	V	

**Notes:**

1. Compliant with IEEE802.3ck C2M.

**Electrical Low-Speed Control and Sense Signal Specifications**

Parameter	Symbol	Min.	Max.	Unit	Notes
Module Output SCL and SDA	VOL	0	0.4	V	
Module Input SCL and SDA	VIL	-0.3	Vcc*0.3	V	
	VIH	Vcc*0.7	Vcc+0.5	V	
InitMode, ResetL, and ModSelL	VIL	-0.3	0.8	V	
	VIH	2	Vcc+0.3	V	
IntL	VOL	0	0.4	V	
	VOH	Vcc-0.5	Vcc+0.3	V	

## Optical Characteristics

Parameter	Symbol	Min.	Typ.	Max.	Unit	Notes
<b>Transmitter</b>						
Wavelength	$\lambda_C$	1304.5	1311	1317.5	nm	
Side-Mode Suppression Ratio	SMSR	30			dB	
Average Launch Power Per Lane	$AOP_L$	-2.9		4.0	dBm	1
Outer Optical Modulation Amplitude (OMA <sub>outer</sub> ) Per Lane	TOMA	-0.8		4.2	dBm	
Launch Power in OMA <sub>outer</sub> Minus TDECQ Per Lane	For ER $\geq$ 5dB	TOMA - TDECQ	-2.2		dBm	
	For ER < 5dB	TOMA - TDECQ	-1.9		dBm	
Transmitter and Dispersion Eye Closure for PAM4 (TDECQ) Per Lane	TDECQ			3.4	dB	
TDECQ – 10log <sub>10</sub> (Ceq) Per Lane	Ceq			3.4	dB	
Average Launch Power of Off Transmitter Per Lane	$T_{off}$			-15	dBm	
Extinction Ratio	ER	3.5			dB	
Transmitter Transition Time	$T_r$			17	ps	
RIN <sub>15.5OMA</sub>	RIN			-136	dB/Hz	
Optical Return Loss Tolerance	ORLT			15.5	dB	
Transmitter Reflectance	TR			-26	dB	2
<b>Receiver (TP4)</b>						
Wavelength	$\lambda_C$	1304.5	1311	1317.5	nm	
Damage Threshold Per Lane	$AOP_D$	5			dBm	
Average Receive Power Per Lane	$AOP_R$	-5.9		4	dBm	
Receive Power (OMA <sub>outer</sub> ) Per Lane	OMA <sub>R</sub>			4.2	dBm	
Receiver Reflectance	RR			-26	dB	
Receiver Sensitivity (OMA <sub>outer</sub> ) Per Lane	SOMA			Max. (-3.9, SECQ – 5.3)	dBm	3
Stressed Receiver Sensitivity (OMA <sub>outer</sub> ) Per Lane	SRS			-1.9	dBm	4
<b>Conditions of Stressed Receiver Sensitivity Test</b>						
Stressed Eye Closure for PAM4 (SECQ) Per Lane Under Test	SECQ		3.4		dB	
SECQ – 10log <sub>10</sub> (Ceq) Per Lane Under Test	Ceq			3.4	dB	

### Notes:

1. Average launch power, per lane (minimum), is informative and not the principal indicator of signal strength.
2. Transmitter reflectance is defined looking into the transmitter.
3. Receiver sensitivity (OMA<sub>outer</sub>), per lane (maximum), is informative and is defined for a transmitter with a value of SECQ up to 3.4dB.
4. Measured with conformance test signal at TP3 for the BER =  $2.4 \times 10^{-4}$ .

## Pin Descriptions

Pin	Logic	Symbol	Name/Description	Notes
1		GND	Module Ground.	
2	CML-I	Tx2+	Transmitter Non-Inverted Data.	
3	CML-I	Tx2-	Transmitter Inverted Data.	
4		GND	Module Ground.	
5	CML-I	Tx4+	Transmitter Non-Inverted Data.	
6	CML-I	Tx4-	Transmitter Inverted Data.	
7		GND	Module Ground.	
8	CML-I	Tx6+	Transmitter Non-Inverted Data.	
9	CML-I	Tx6-	Transmitter Inverted Data.	
10		GND	Module Ground.	
11	CML-I	Tx8+	Transmitter Non-Inverted Data.	
12	CML-I	Tx8-	Transmitter Inverted Data.	
13		GND	Module Ground.	
14	LVC MOS-I/O	SCL	2-Wire Serial Interface Clock.	
15		Vcc	+3.3V Power Supply.	
16		Vcc	+3.3V Power Supply.	
17	Multi-Level	LPWn/PRSn	Low-Power Mode/Module Present.	
18		GND	Module Ground.	
19	CML-O	Rx7-	Receiver Inverted Data.	
20	CML-O	Rx7+	Receiver Non-Inverted Data.	
21		GND	Module Ground.	
22	CML-O	Rx5-	Receiver Inverted Data.	
23	CML-O	Rx5+	Receiver Non-Inverted Data.	
24		GND	Module Ground.	
25	CML-O	Rx3-	Receiver Inverted Data.	
26	CML-O	Rx3+	Receiver Non-Inverted Data.	
27		GND	Module Ground.	
28	CML-O	Rx1-	Receiver Inverted Data.	
29	CML-O	Rx1+	Receiver Non-Inverted Data.	
30		GND	Module Ground.	
31		GND	Module Ground.	
32	CML-O	Rx2+	Receiver Non-Inverted Data.	
33	CML-O	Rx2-	Receiver Inverted Data.	
34		GND	Module Ground.	
35	CML-O	Rx4+	Receiver Non-Inverted Data.	
36	CML-O	Rx4-	Receiver Inverted Data.	

37		GND	Module Ground.	
38	CML-O	Rx6+	Receiver Non-Inverted Data.	
39	CML-O	Rx6-	Receiver Inverted Data.	
40		GND	Module Ground.	
41	CML-O	Rx8+	Receiver Non-Inverted Data.	
42	CML-O	Rx8-	Receiver Inverted Data.	
43		GND	Module Ground.	
44	Multi-Level	INT/RSTn	Module Input/Module Reset.	
45		Vcc	+3.3V Power Supply.	
46		Vcc	+3.3V Power Supply.	
47	LVC MOS-I/O	SDA	2-Wire Serial Interface Data.	
48		GND	Module Ground.	
49	CML-I	Tx7-	Transmitter Inverted Data.	
50	CML-I	Tx7+	Transmitter Non-Inverted Data.	
51		GND	Module Ground.	
52	CML-I	Tx5-	Transmitter Inverted Data.	
53	CML-I	Tx5+	Transmitter Non-Inverted Data.	
54		GND	Module Ground.	
55	CML-I	Tx3-	Transmitter Inverted Data.	
56	CML-I	Tx3+	Transmitter Non-Inverted Data.	
57		GND	Module Ground.	
58	CML-I	Tx1-	Transmitter Inverted Data.	
59	CML-I	Tx1+	Transmitter Non-Inverted Data.	
60		GND	Module Ground.	

# Electrical Pad Layout

Top Side (viewed from top)

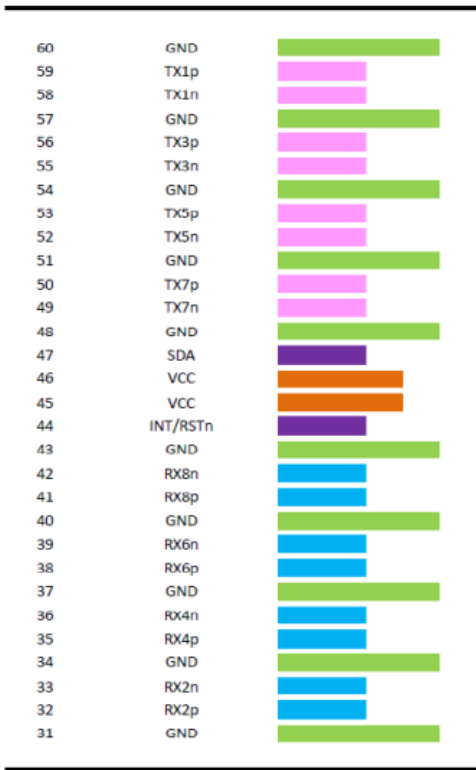

Bottom Side (viewed from bottom)

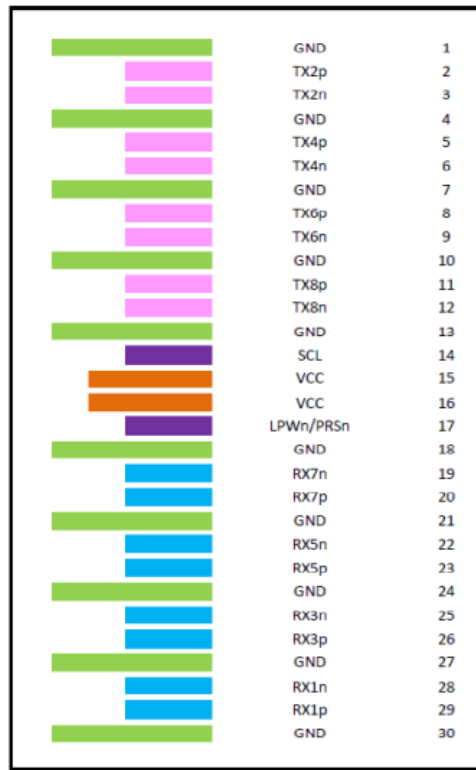

----- Module Card Edge -----

# Recommended OSFP Host Board Schematic

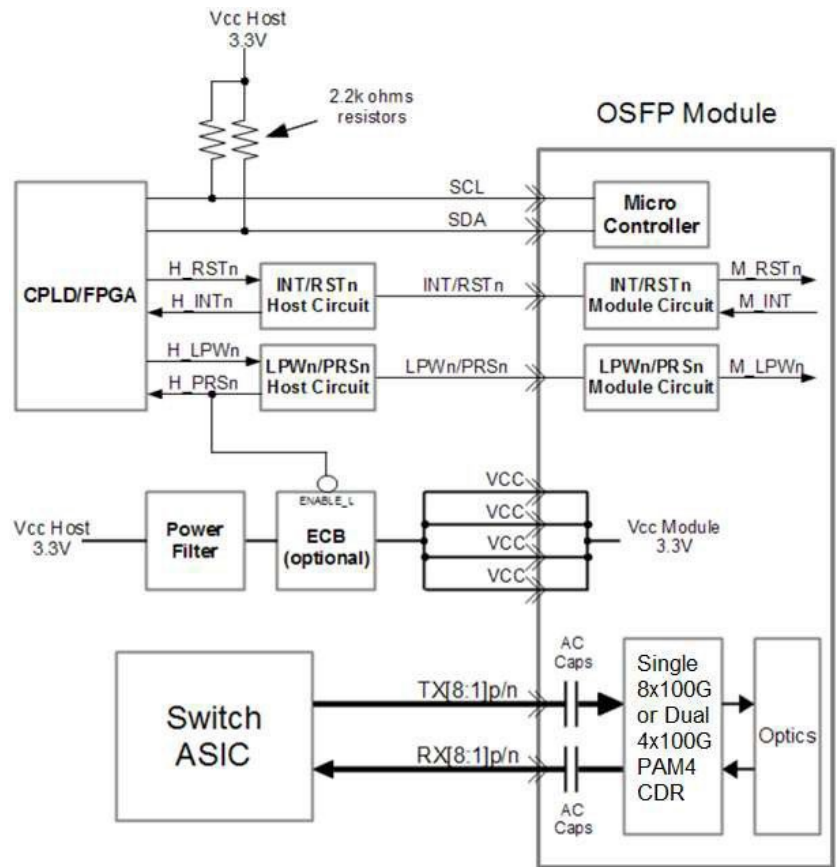

# Mechanical Specifications

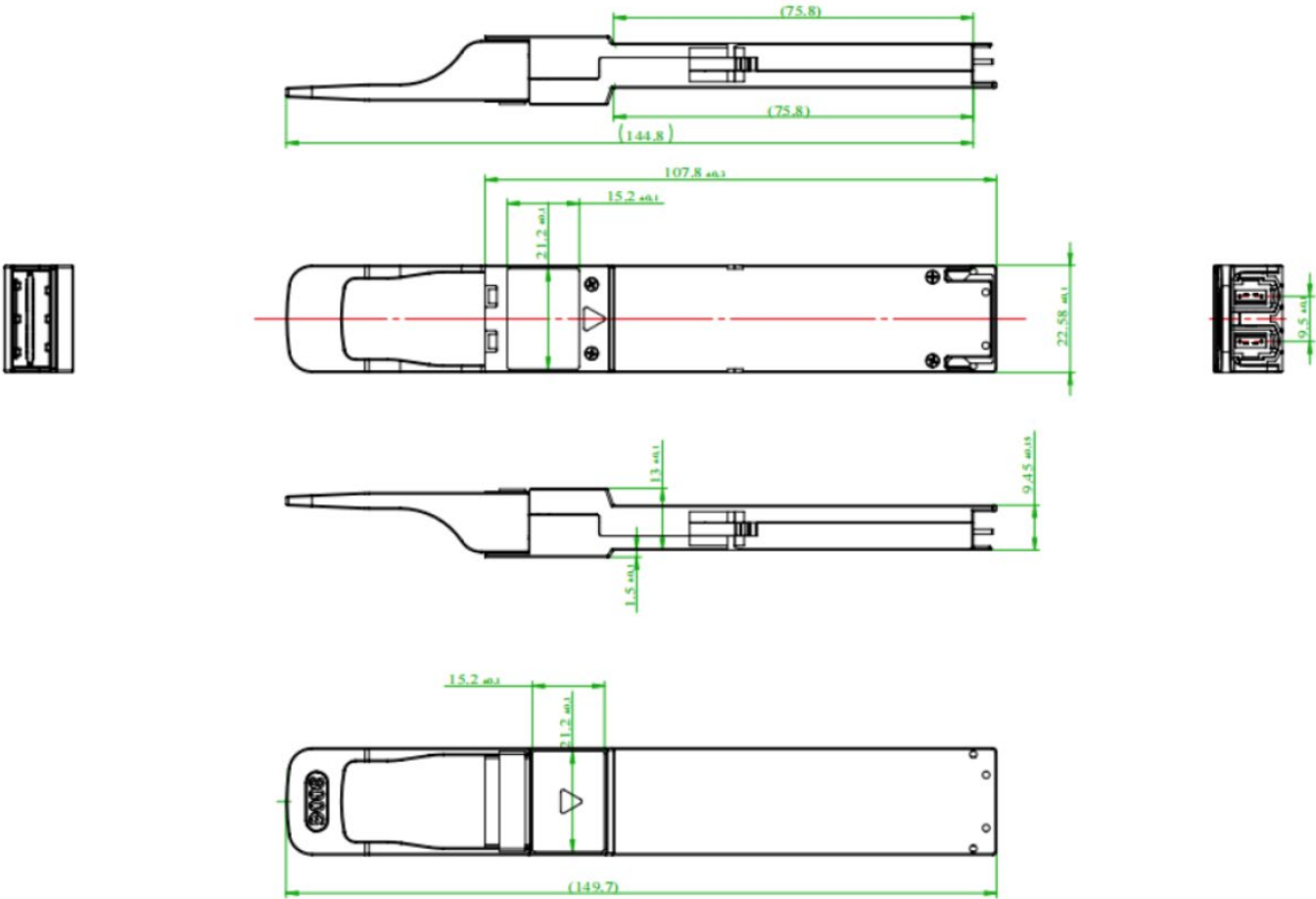

## About ProLabs

Our extensive experience comes as standard. For over 20 years ProLabs has delivered optical connectivity solutions that give our customers freedom and choice through our ability to provide seamless interoperability. At the heart of our company is the ability to provide state-of-the-art optical transport and connectivity solutions that are compatible with more than 100 optical switching and transport platforms.

## A Complete Portfolio of Network Solutions

ProLabs is focused on innovations in optical transport and connectivity. The combination of our knowledge of optics and networking equipment enables ProLabs to be your single source for optical transport and connectivity solutions from 100Mb to 1.6T while providing innovative solutions that increase network efficiency. We provide the optical connectivity expertise that is compatible with and enhances your switching and transport equipment.

## The Trusted Partner

Customer service is our number one value. ProLabs has invested in people, labs and manufacturing capacity to ensure compatible products, and immediate answers to your questions. With Engineering and Manufacturing offices in the U.K. and U.S. augmented by field offices throughout the U.S., U.K. and Asia, ProLabs is able to be our customers best advocate 24 hours a day.



## Contact Information

ProLabs US

Email: [sales@prolabs.com](mailto:sales@prolabs.com)

Telephone: 952-852-0252

ProLabs UK

Email: [salessupport@prolabs.com](mailto:salessupport@prolabs.com)

Telephone: +44 1285 719 600