

MMS4X00-NM-T-C

Mellanox® MMS4X00-NM-T Compatible TAA 800GBase-DR8 PAM4 OSFP-IHS Transceiver (SMF, 1310nm, 500m, 2xMPO-12, DOM, CMIS 5.0)

Features:

- OSFP MSA Compliant
- 8x53.125GBd (PAM4) Electrical Interface
- Supports 850Gbps
- Support both Ethernet and InfiniBand NDR
- Compliant with IEEE 802.3cu-2021: 8x100GBASE-DR optical interface
- Compliant with IEEE 802.3ck-2022: 8x100GAUI-1 C2M electrical interface
- Commercial Temperature: 0 to 70 Celsius
- EML transmitter and PIN PD receiver
- Dual MPO-12 Connector APC
- Class 1 Laser
- RoHS Compliant and Lead-Free

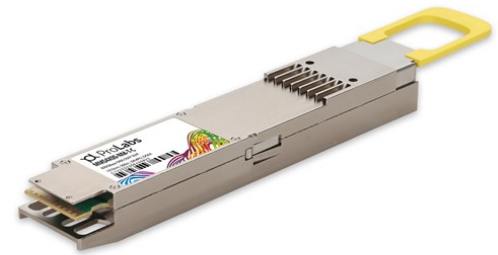

Applications:

- 8x100GBase Ethernet
- 2x400GBase Ethernet

Product Description

This Mellanox® MMS4X00-NM-T compatible OSFP-IHS Transceiver provides 800GBase-DR8 throughput up to 500m over single-mode fiber (SMF) PAM4 using a wavelength of 1310nm via a 2xMPO-12 connector. It can operate at temperatures between 0 and 70C. Our transceiver is built to meet or exceed OEM specifications and is guaranteed to be 100% compatible with Mellanox®. It has been programmed, uniquely serialized, and tested for data-traffic and application to ensure that it will initialize and perform identically. All of our transceivers comply with Multi-Source Agreement (MSA) standards to provide seamless network integration. Additional product features include Digital Optical Monitoring (DOM) support which allows access to real-time operating parameters. This transceiver is Trade Agreements Act (TAA) compliant. We stand behind the quality of our products and proudly offer a limited lifetime warranty.

ProLabs' transceivers are RoHS compliant and lead-free.

TAA refers to the Trade Agreements Act (19 U.S.C. & 2501-2581), which is intended to foster fair and open international trade. TAA requires that the U.S. Government may acquire only "U.S.-made or designated country end products.")



Absolute Maximum Ratings

Parameter	Symbol	Min.	Typ.	Max.	Unit	Notes
Power Supply Voltage	V _{CC}	-0.5		3.6	V	
Storage Temperature	T _{stg}	-40		85	°C	
Operating Case Temperature	T _c	0		70	°C	
Relative Humidity (non-condensing)	RH	5		95	%	
Data Input Voltage Differential	V _{DIP-V_{DIN}}			1	V	
Control Input Voltage	V _I	-0.3		V _{CC} +0.5	V	
Control Output Current	I _O	-20		20	mA	
Signaling Speed per Lane	DRL		53.125		GBd	
Operating Distance		2		500	m	

Notes:

- Exceeding the Absolute Maximum Ratings table may cause permanent damage to the device. This is just an emphasized rating and does not involve the functional operation of the device that exceeds the specifications of this technical specification under these or other conditions. Long-term operation under Absolute Maximum Ratings will affect the reliability of the device.

Electrical Characteristics

Parameter	Symbol	Min.	Typ.	Max.	Unit	Notes
Power Supply Voltage	V _{CC}	3.135	3.3	3.465	V	
Instantaneous peak current at hot plug	I _{CC_IP}			6600	mA	
Sustained peak current at hot plug	I _{CC_SP}			5494.5	mA	
Maximum Power Dissipation	P _D			16.5	W	
Maximum Power Dissipation, Low Power Mode	P _{DLP}			2	W	
Control Input Voltage High	V _{IH}	V _{CC} *0.7		V _{CC} +0.3	V	
Control Input Voltage Low	V _{IL}	-0.3		V _{CC} *0.3	V	
Two Wire Serial Interface Clock Rate				400	kHz	
Power Supply Noise 1 kHz - 1 MHz (p-p)				66	mVpp	
High-Speed Electrical Transmitter Characteristics (TP1)						
Differential Peak-Peak Input Voltage Tolerance		750			mV	
Peak-to-Peak AC Common-Mode Voltage Tolerance	Low-frequency, V _{CM_LF}			32	mV	
	Full-band, V _{CM_FB}			80	mV	
Differential-mode to common-mode return loss	RL _{cd}	802.3ck 120G-2			dB	
Effective return loss	ERL	8.5			dB	
Differential termination mismatch				10	%	

Single-ended voltage tolerance range			-0.4		3.3	V	
DC common-mode voltage tolerance			-0.35		2.85	V	
High-Speed Electrical Receiver Characteristics (TP4)							
Peak-to-Peak AC Common-Mode Voltage	Low-frequency, $V_{CM_{LF}}$				32	mV	
	Full-band, $V_{CM_{FB}}$				80	mV	
Differential Peak-to-Peak Output Voltage	Short Mode				600	mV	
	Long Mode				845	mV	
Eye height	EH	15				mV	
Vertical eye closure	VEC				12	dB	
Common-mode to differential-mode return loss	RLDc	802.3ck 120G-1				dB	
Effective return loss	ERL	8.5				dB	
Differential termination mismatch					10	%	
Transition time		8.5				ps	
DC common-mode voltage tolerance			-0.35		2.85	V	

Notes:

1. Compliant with IEEE802.3ck C2M.

Electrical Low Speed Control and Sense Signals Specifications

Parameter	Symbol	Min.	Max.	Unit	Notes
Module output SCL and SDA	VOL	0	0.4	V	
Module Input SCL and SDA	VIL	-0.3	VCC*0.3	V	
	VIH	VCC*0.7	VCC+0.5	V	
InitMode, ResetL and ModSelL	VIL	-0.3	0.8	V	
	VIH	2	VCC+0.3	V	
IntL	VOL	0	0.4	V	
	VOH	VCC-0.5	VCC+0.3	V	

Optical Characteristics

Parameter	Symbol	Min.	Typ.	Max.	Unit	Notes
Transmitter						
Wavelength	λ_C	1304.5	1311	1317.5	nm	
Side Mode Suppression Ratio	SMSR	30			dB	
Average Launch Power, each lane	AOPL	-2.9		4.0	dBm	1
Outer Optical Modulation Amplitude (OMA _{outer}), each Lane	TOMA	-0.8		4.2	dBm	
Launch power in OMA _{outer} Minus TDECQ, each lane	for extinction ratio ≥ 5 dB	TOMA-TDECQ	-2.2		dBm	
	for extinction ratio < 5 dB	TOMA-TDECQ	-1.9		dBm	
Transmitter and Dispersion Eye Closure for PAM4 (TDECQ), each lane	TDECQ			3.4	dB	
TDECQ – $10\log_{10}(C_{eq})$, each lane	C _{eq}			3.4	dB	
Average Launch Power of OFF Transmitter, each lane	TOFF			-15	dBm	
Extinction Ratio	ER	3.5			dB	
Transmitter Transition Time	T _r			17	ps	
RIN _{15.5,OMA}	RIN			-136	dB/Hz	
Optical Return Loss Tolerance	ORL			15.5	dB	
Transmitter Reflectance	T _R			-26	dB	2
Receiver						
Wavelength	λ_{C0}	1304.5	1311	1317.5	nm	
Damage Threshold, each Lane	AOP _D	5			dBm	
Average Receive Power, each Lane	AOP _R	-5.9		4	dBm	
Receive Power (OMA _{outer}), each Lane	OMA _R			4.2	dBm	
Receiver Reflectance	RR			-26	dB	
Receiver Sensitivity (OMA _{outer}), each Lane	SOMA			Max (-3.9, SECQ – 5.3)	dBm	3
Stressed Receiver Sensitivity (OMA _{outer}), each Lane	SRS			-1.9	dBm	4
Conditions of Stressed Receiver Sensitivity Test						
Stressed Eye Closure for PAM4 (SECQ), Lane Under Test	SECQ		3.4		dB	
SECQ – $10\log_{10}(C_{eq})$, Lane Under Test	C _{eq}			3.4	dB	

Notes:

1. Average launch power, each lane (min) is informative and not the principal indicator of signal strength.
2. Transmitter reflectance is defined looking into the transmitter.
3. Receiver sensitivity (OMA_{outer}), each lane (max) is informative and is defined for a transmitter with a value of SECQ up to 3.4dB.
4. Measured with conformance test signal at TP3 for the BER = 2.4×10^{-4} .

Pin Descriptions

Pin	Logic	Symbol	Name/Description	Notes
1		GND	Module Ground.	
2	CML-I	Tx2+	Transmitter Non-Inverted Data.	
3	CML-I	Tx2-	Transmitter Inverted Data.	
4		GND	Module Ground.	
5	CML-I	Tx4+	Transmitter Non-Inverted Data.	
6	CML-I	Tx4-	Transmitter Inverted Data.	
7		GND	Module Ground.	
8	CML-I	Tx6+	Transmitter Non-Inverted Data.	
9	CML-I	Tx6-	Transmitter Inverted Data.	
10		GND	Module Ground.	
11	CML-I	Tx8+	Transmitter Non-Inverted Data.	
12	CML-I	Tx8-	Transmitter Inverted Data.	
13		GND	Module Ground.	
14	LVC MOS-I/O	SCL	2-Wire Serial Interface Clock.	
15		Vcc	+3.3V Power Supply.	
16		Vcc	+3.3V Power Supply.	
17	Multi-Level	LPWn/PRSn	Low-Power Mode/Module Present.	
18		GND	Module Ground.	
19	CML-O	Rx7-	Receiver Inverted Data.	
20	CML-O	Rx7+	Receiver Non-Inverted Data.	
21		GND	Module Ground.	
22	CML-O	Rx5-	Receiver Inverted Data.	
23	CML-O	Rx5+	Receiver Non-Inverted Data.	
24		GND	Module Ground.	
25	CML-O	Rx3-	Receiver Inverted Data.	
26	CML-O	Rx3+	Receiver Non-Inverted Data.	
27		GND	Module Ground.	
28	CML-O	Rx1-	Receiver Inverted Data.	
29	CML-O	Rx1+	Receiver Non-Inverted Data.	
30		GND	Module Ground.	
31		GND	Module Ground.	
32	CML-O	Rx2+	Receiver Non-Inverted Data.	
33	CML-O	Rx2-	Receiver Inverted Data.	
34		GND	Module Ground.	
35	CML-O	Rx4+	Receiver Non-Inverted Data.	

36	CML-O	Rx4-	Receiver Inverted Data.	
37		GND	Module Ground.	
38	CML-O	Rx6+	Receiver Non-Inverted Data.	
39	CML-O	Rx6-	Receiver Inverted Data.	
40		GND	Module Ground.	
41	CML-O	Rx8+	Receiver Non-Inverted Data.	
42	CML-O	Rx8-	Receiver Inverted Data.	
43		GND	Module Ground.	
44	Multi-Level	INT/RSTn	Module Input/Module Reset.	
45		Vcc	+3.3V Power Supply.	
46		Vcc	+3.3V Power Supply.	
47	LVCNOS-I/O	SDA	2-Wire Serial Interface Data.	
48		GND	Module Ground.	
49	CML-I	Tx7-	Transmitter Inverted Data.	
50	CML-I	Tx7+	Transmitter Non-Inverted Data.	
51		GND	Module Ground.	
52	CML-I	Tx5-	Transmitter Inverted Data.	
53	CML-I	Tx5+	Transmitter Non-Inverted Data.	
54		GND	Module Ground.	
55	CML-I	Tx3-	Transmitter Inverted Data.	
56	CML-I	Tx3+	Transmitter Non-Inverted Data.	
57		GND	Module Ground.	
58	CML-I	Tx1-	Transmitter Inverted Data.	
59	CML-I	Tx1+	Transmitter Non-Inverted Data.	
60		GND	Module Ground.	

Electrical Pad Layout

Top Side (viewed from top)

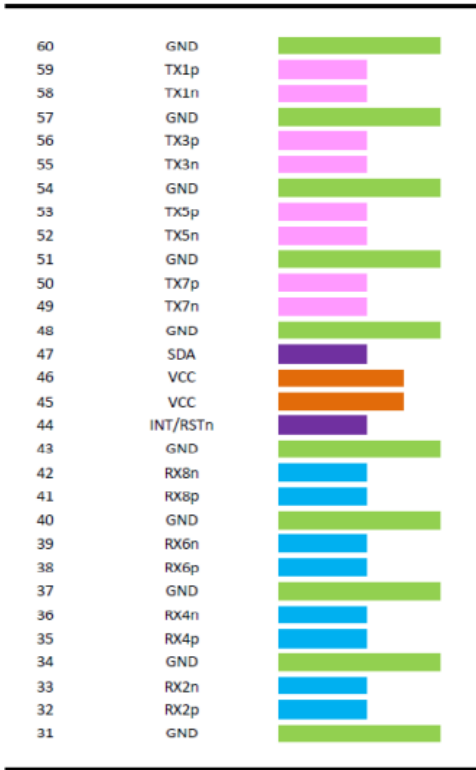

Bottom Side (viewed from bottom)

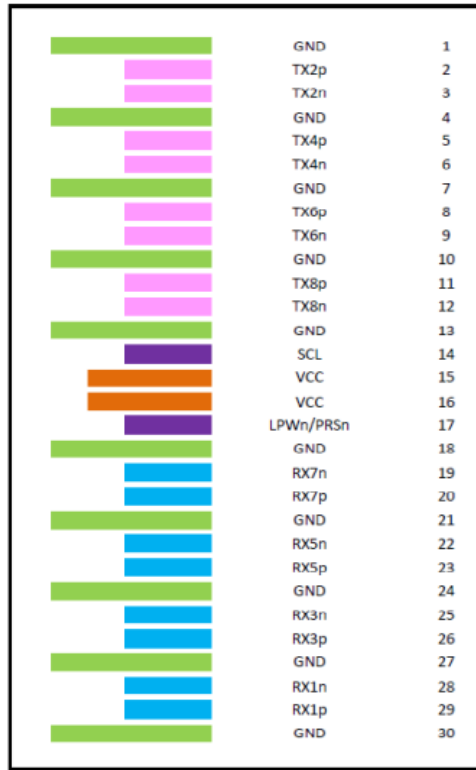

----- Module Card Edge -----

Recommended OSFP Host board Schematic

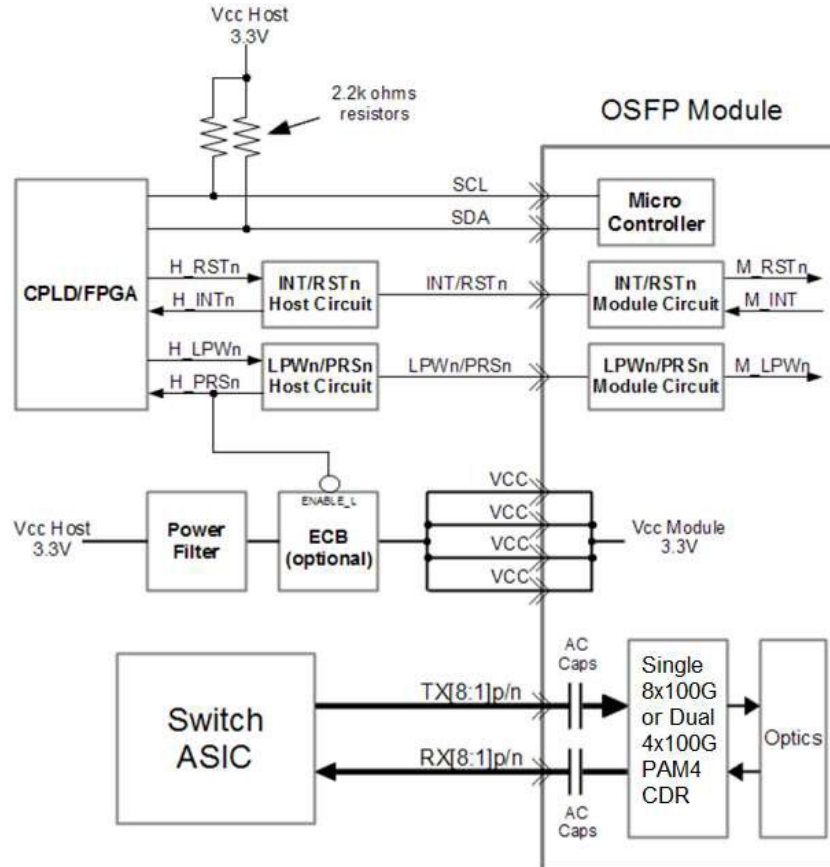

Mechanical Specifications

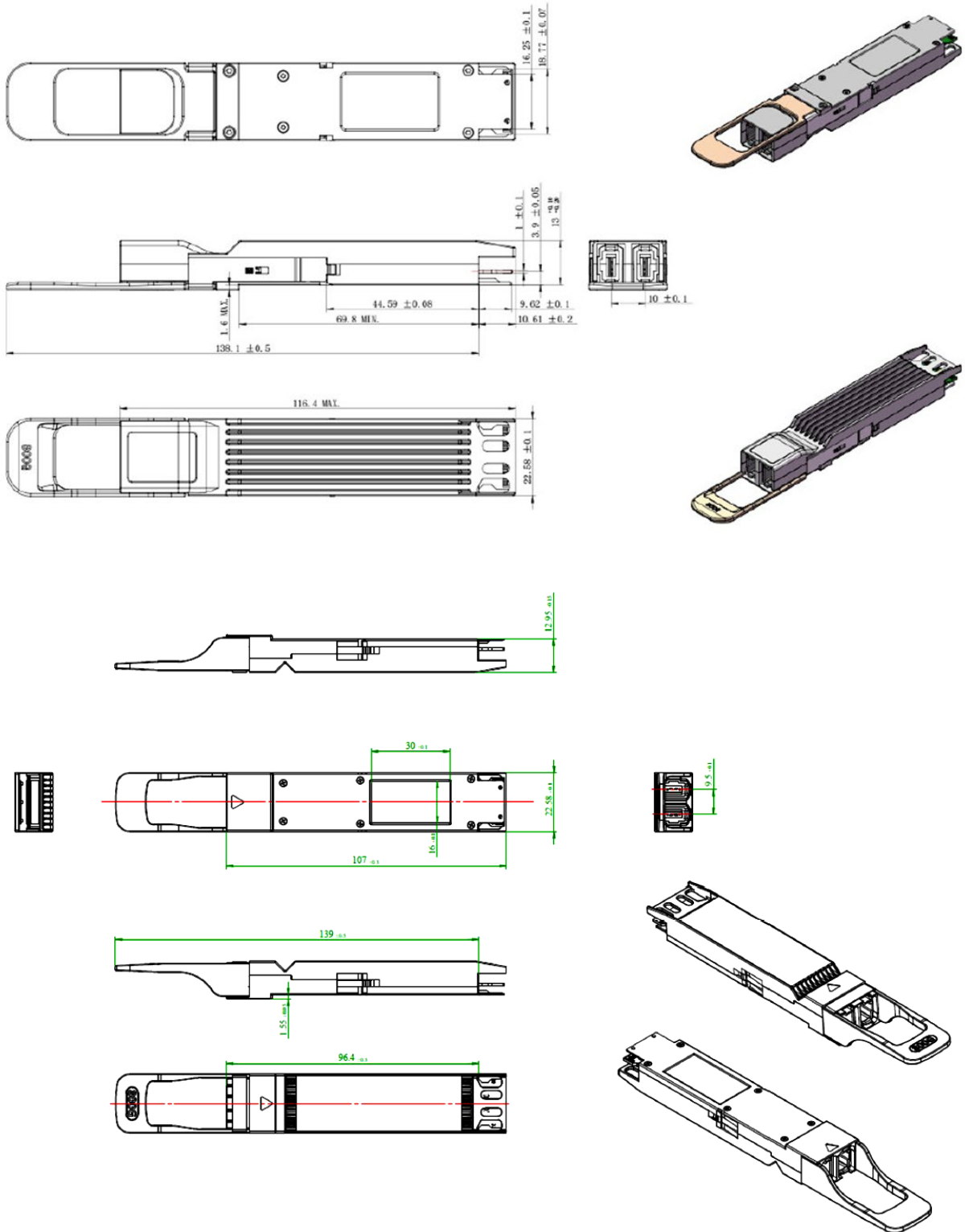

*Note: Both Heat Sink Exposed and Heat Sink Enclosed styles are OSFP Type 2 Compliant. Images are for Illustration purposes only. Product Labels, colors, and style may vary.

About ProLabs

Our extensive experience comes as standard. For over 20 years ProLabs has delivered optical connectivity solutions that give our customers freedom and choice through our ability to provide seamless interoperability. At the heart of our company is the ability to provide state-of-the-art optical transport and connectivity solutions that are compatible with more than 100 optical switching and transport platforms.

A Complete Portfolio of Network Solutions

ProLabs is focused on innovations in optical transport and connectivity. The combination of our knowledge of optics and networking equipment enables ProLabs to be your single source for optical transport and connectivity solutions from 100Mb to 1.6T while providing innovative solutions that increase network efficiency. We provide the optical connectivity expertise that is compatible with and enhances your switching and transport equipment.

The Trusted Partner

Customer service is our number one value. ProLabs has invested in people, labs and manufacturing capacity to ensure compatible products, and immediate answers to your questions. With Engineering and Manufacturing offices in the U.K. and U.S. augmented by field offices throughout the U.S., U.K. and Asia, ProLabs is able to be our customers best advocate 24 hours a day.



Contact Information

ProLabs US

Email: sales@prolabs.com

Telephone: 952-852-0252

ProLabs UK

Email: salessupport@prolabs.com

Telephone: +44 1285 719 600