

QSFP112-400GB-VR4-MX-AO

Mellanox® Compatible TAA 400GBase-VR4 PAM4 QSFP112 Transceiver (MMF, 850nm, 50m, MPO-12, DOM, CMIS 5.2)

Features

- 4 Independent Parallel Optical Channels
- Hot-Pluggable
- Each Channel Data Rate Up to 53.12GBaud
- 850nm VCSEL/PD Array Technology
- QSFP112 MSA Compliant
- Up to 50m Link Over OM4 Multi-Mode
- MPO-12 APC Optical Receptacle Type
- Optical Connectivity Via Industry Standard MPO Terminated Fiber Ribbon
- Operating Temperature: 15 to 70 Celsius
- CMIS 5.2 Compliant
- RoHS Compliant and Lead-Free

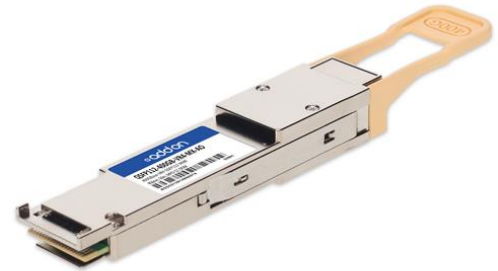

Applications

- 400GBase Ethernet

Product Description

This Mellanox® compatible QSFP112 transceiver provides 400GBase-VR4 throughput up to 50m over multi-mode fiber (MMF) using a wavelength of 850nm via a MPO-12 connector. It can operate at temperatures between 15 and 70C. Our transceiver is built to meet or exceed OEM specifications and is guaranteed to be 100% compatible with Mellanox®. It has been programmed, uniquely serialized, and tested for data-traffic and application to ensure that it will initialize and perform identically. All of our transceivers comply with Multi-Source Agreement (MSA) standards to provide seamless network integration. Additional product features include Digital Optical Monitoring (DOM) support which allows access to real-time operating parameters. This transceiver is Trade Agreements Act (TAA) compliant. We stand behind the quality of our products and proudly offer a limited lifetime warranty.

AddOn's transceivers are RoHS compliant and lead-free.

TAA refers to the Trade Agreements Act (19 U.S.C. & 2501-2581), which is intended to foster fair and open international trade. TAA requires that the U.S. Government may acquire only "U.S.-made or designated country end products."



Absolute Maximum Ratings

Parameter	Symbol	Min.	Max.	Unit
Storage Ambient Temperature	Tstg	-40	+85	°C
Relative Humidity – Storage	RHs	0	95	%
Relative Humidity – Operating	RHo	0	85	%
Module Supply Voltage	Vcc	-0.5	3.6	V

Notes:

1. Exceeding the Absolute Maximum Ratings may cause irreversible damage to the device. The device is not intended to be operated under the condition of simultaneous Absolute Maximum Ratings, a condition which may cause irreversible damage to the device. RH is a non-condensing condition.

Recommended Operating Conditions

Parameter	Symbol	Min.	Typ.	Max.	Unit
Case Operating Temperature	Tc	+15	+25	+70	°C
Module Supply Voltage	Vcc	3.14	3.3	3.46	V
Single Module Supply Current	I _{IN}		2450		mA
Signaling Speed Per Channel	S		53.12		GBaud

Electrical Characteristics

Parameter	Symbol	Min.	Typ.	Max.	Unit	Notes
Transmitter						
Tx_Data Differential Input Voltage	V _{IN}	750			mV	
Tx_Data Differential Input Impedance	Z _{IN}		100		Ω	
Receiver						
Rx_Data Differential Output Voltage	V _{OUT}			845	mV	
Rx_Data Differential Output Impedance	Z _{OUT}	90	100	110	Ω	
Link BER	BER			24E ⁻⁴		1

Notes:

1. Better than 2.4E⁻⁴ @53.12GBaud PRBS31Q.

Optical Characteristics

Parameter	Symbol	Min.	Typ.	Max.	Unit	Notes
Transmitter						
Signaling Rate Per Lane	SR		53.12		GBd	
Signaling Speed Accuracy	SSA	-100		100	ppm	
Modulation Format		PAM4				
Average Launch Power Per Lane	POUT	-4.6		4	dBm	1
Outer Optical Modulation Amplitude Per Lane	OMA _{outer}	-2.6		3.5	dBm	
Optical Output with Tx Off	P _{off}			-30	dBm	
Extinction Ratio	ER	2.5			dB	
Center Wavelength	λ	842	860	870	nm	
RMS Spectral Width	$\Delta\lambda$			0.65	nm	
Transmitter and Dispersion Eye Closure (TDECQ) Per Lane	TDECQ			4.4	dB	
Overshoot/Undershoot (Maximum)				29	%	
RIN _{OMA}	RIN _{OMA}			-132	dB/Hz	
Optical Return Loss Tolerance (Maximum)	ORLT			14	dB	
Receiver						
Signaling Rate Per Lane	SR		53.12		GBd	
Signaling Speed Accuracy		-100		100	ppm	
Modulation Format			PAM4		dBm	
Average Power at Receive Input Per Lane	PIN	-6.3		4	dBm	2
Receive Power (OMA _{outer}) Per Lane (Maximum)				3.5	dBm	
Receiver Sensitivity (OMA _{outer}) Per Lane For TECQ \leq 1.8dB	Sen			-4.4	dBm	
Receiver Sensitivity (OMA _{outer}) Per Lane For 1.8<TECQ \leq 4.4dB	Sen			-6.2+TECQ	dBm	3
Center Wavelength	λ	842	860	870	nm	
Rx_LOS of Signal – Assert	P _A	-24.6			dBm	
Rx_LOS of Signal – De-Assert	P _D			-7	dBm	
Rx_LOS of Signal – Hysteresis	P _{HY}	0.5			dB	

Notes:

1. Average optical output.
2. Average receiver power where the BER=2.4E⁻⁴ measured with a PRBS31Q test pattern @53.12GBaud.
3. Sensitivity where the BER=2.4E⁻⁴ with a PRBS31Q test pattern @53.12GBaud.

Pin Descriptions

Pin	Symbol	Name/Description	Notes
1	GND	Module Ground.	
2	Tx2n	Transmitter Inverted Data Input.	
3	Tx2p	Transmitter Non-Inverted Data Input.	
4	GND	Module Ground.	
5	Tx4n	Transmitter Inverted Data Input.	
6	Tx4p	Transmitter Non-Inverted Data Input.	
7	GND	Module Ground.	
8	ModSelL	Module Select.	
9	ResetL	Module Reset.	
10	VccRx	+3.3V DC Receiver Power Supply.	
11	SCL	2-Wire Serial Clock.	
12	SDA	2-Wire Serial Data.	
13	GND	Module Ground.	
14	Rx3p	Receiver Non-Inverted Data Output.	
15	Rx3n	Receiver Inverted Data Output.	
16	GND	Module Ground.	
17	Rx1p	Receiver Non-Inverted Data Output.	
18	Rx1n	Receiver Inverted Data Output.	
19	GND	Module Ground.	
20	GND	Module Ground.	
21	Rx2n	Receiver Inverted Data Output.	
22	Rx2p	Receiver Non-Inverted Data Output.	
23	GND	Module Ground.	
24	Rx4n	Receiver Inverted Data Output.	
25	Rx4p	Receiver Non-Inverted Data Output.	
26	GND	Module Ground.	
27	ModPrsL	Module Present.	
28	IntL/RxLOS	Interrupt/Optional RxLOS.	
29	VccTx	+3.3V DC Transmitter Power Supply.	
30	Vcc1	+3.3V DC Power Supply.	
31	LPMoDe/TxDis	Low-Power Mode/Optional TxDisable.	
32	GND	Module Ground.	
33	Tx3p	Transmitter Non-Inverted Data Input.	
34	Tx3n	Transmitter Inverted Data Input.	
35	GND	Module Ground.	

36	Tx1p	Transmitter Non-Inverted Data Input.	
37	Tx1n	Transmitter Inverted Data Input.	
38	GND	Module Ground.	

Pin Assignments

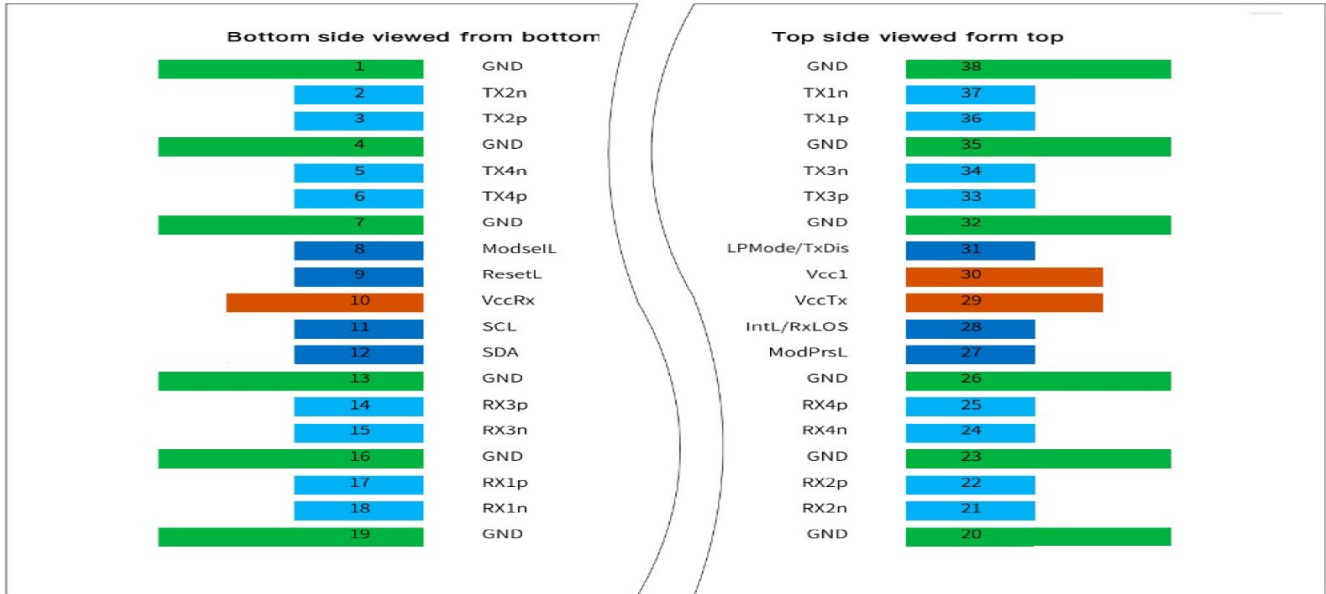

Block Diagram

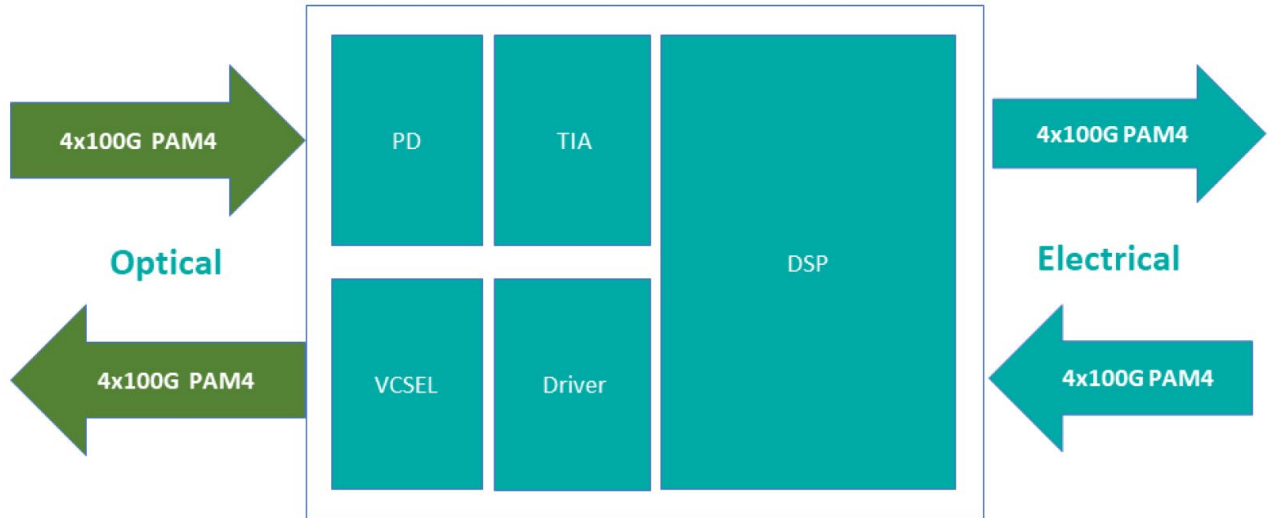

Electrical Interface

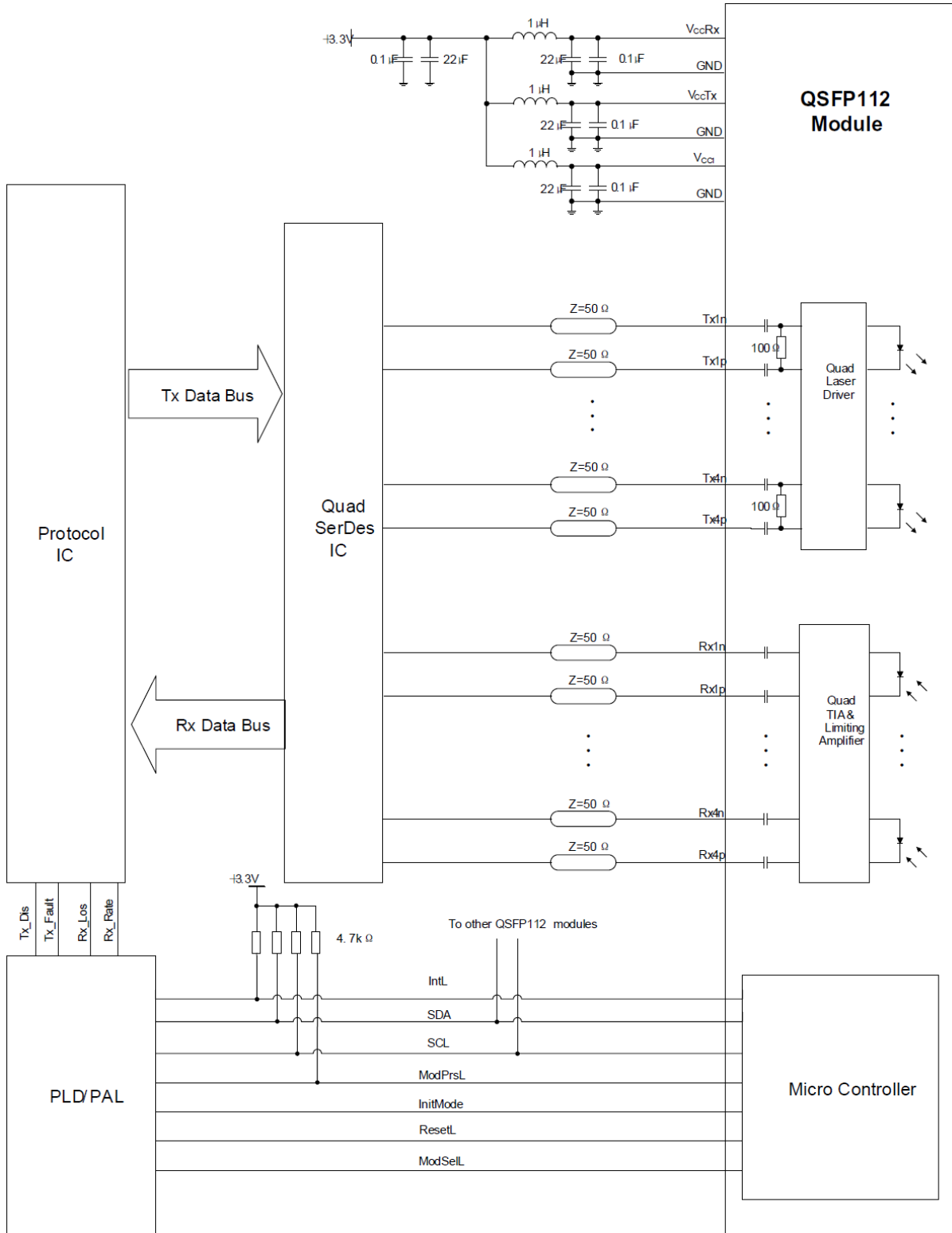

Mechanical Specifications

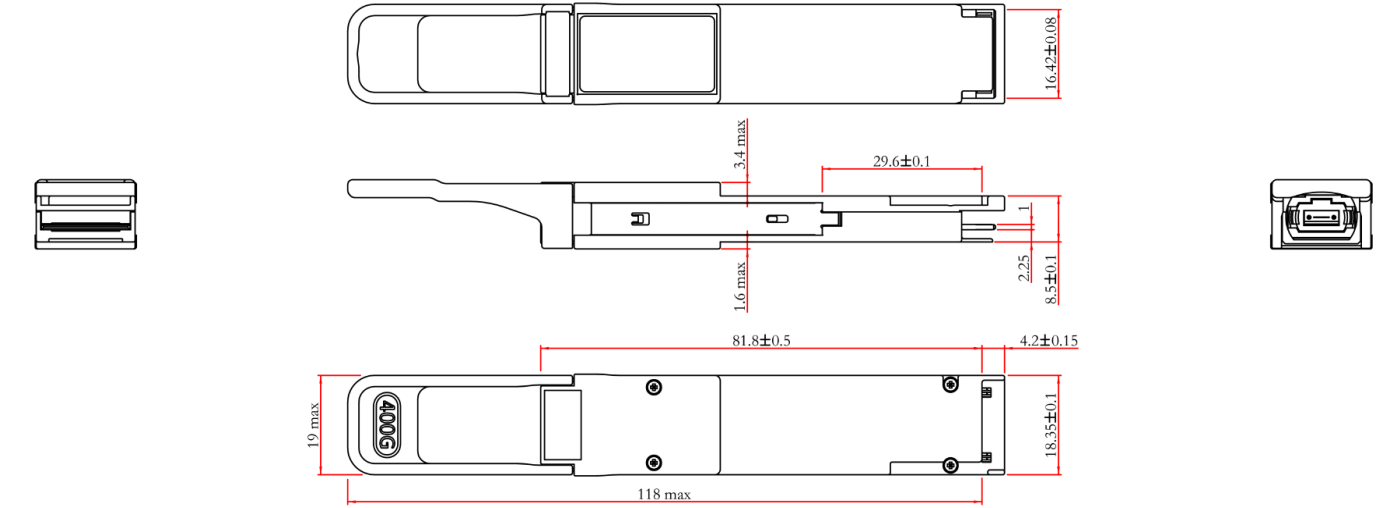

Notes:

1. Tolerance: ± 0.1 mm.
2. Others according with QSFP12 MSA or customer specifications.
3. Light port according to fiber connector specifications.

Optical Lane Assignment

Connector type: MPO-12.

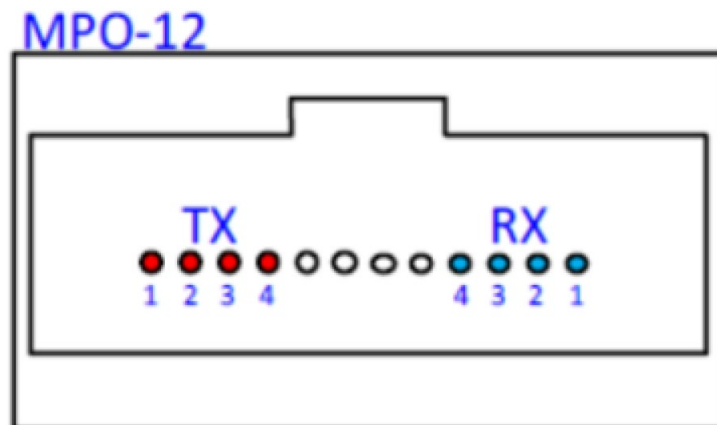

About AddOn Networks

In 1999, AddOn Networks entered the market with a single product. Our founders fulfilled a severe shortage for compatible, cost-effective optical transceivers that compete at the same performance levels as leading OEM manufacturers. Adhering to the idea of redefining service and product quality not previously had in the fiber optic networking industry, AddOn invested resources in solution design, production, fulfillment, and global support.

Combining one of the most extensive and stringent testing processes in the industry, an exceptional free tech support center, and a consistent roll-out of innovative technologies, AddOn has continually set industry standards of quality and reliability throughout its history.

Reliability is the cornerstone of any optical fiber network and is ingrained in AddOn's DNA. It has played a key role in nurturing the long-term relationships developed over the years with customers. AddOn remains committed to exceeding industry standards with certifications ranging from NEBS Level 3 to ISO 9001:2015 with every new development while maintaining the signature reliability of its products.



U.S. Headquarters

Email: sales@addonnetworks.com

Telephone: +1 877.292.1701

Fax: 949.266.9273

Europe Headquarters

Email: salesemea@addonnetworks.com

Telephone: +44 1285 842070