

## MMS4X50-NM-AO

Mellanox® MMS4X50-NM Compatible TAA 800GBase-2xFR4 PAM4 OSFP-IHS Transceiver (SMF, 1310nm, 2km, 2xLC, DOM, CMIS 5.0)

### Features

- Supports Both Ethernet and InfiniBand NDR
- 2x400GBASE-FR4 Optical Interface
- 2x400GAUI-4 C2M Electrical Interface
- InfiniBand NDR Electrical and Optical Interface
- Type 2 Housing with Dual LC Connector
- Support 850Gbps Aggregate Bit Rate
- I2C Management Interface Compliant to CMIS Rev5.0
- Class 1 Laser Certified
- Operating Temperature: 0 to 70 Celsius
- Hot-Pluggable OSFP Form Factor
- RoHS Compliant and Lead-Free



### Applications

- 2x400GBase Ethernet

### Product Description

This Mellanox® MMS4X50-NM compatible OSFP-IHS Transceiver provides 800GBase-2xFR4 throughput up to 2km over single-mode fiber (SMF) PAM4 using a wavelength of 1310nm via a 2xLC connector. It can operate at temperatures between 0 and 70C. All of our transceivers are built to comply with Multi-Source Agreement (MSA) standards and are uniquely serialized and tested for data-traffic and application to ensure seamless network integration. Additional product features include Digital Optical Monitoring (DOM) support which allows access to real-time operating parameters. This transceiver is Trade Agreements Act (TAA) compliant. We stand behind the quality of our products and proudly offer a limited lifetime warranty.

AddOn's transceivers are RoHS compliant and lead-free.

TAA refers to the Trade Agreements Act (19 U.S.C. & 2501-2581), which is intended to foster fair and open international trade. TAA requires that the U.S. Government may acquire only "U.S.-made or designated country end products."



## Absolute Maximum Ratings

Parameter	Symbol	Min.	Typ.	Max.	Unit	Notes
Power Supply Voltage	Vcc	-0.5		3.6	V	
Storage Temperature	Tstg	-40		85	°C	
Operating Case Temperature	Tc	0		70	°C	1
Relative Humidity (Non-Condensing)	RH	5		95	%	
Maximum Power Dissipation	PDISS			16.5	W	
Maximum Power Dissipation (Low-Power Mode)	PDLP			2	W	
Signaling Speed Per Lane	DRL		53.125		GBd	
Operating Distance		2		2000	m	

## Electrical Characteristics

Parameter	Symbol	Min.	Typ.	Max.	Unit	Notes
Power Supply Voltage	Vcc	3.135	3.3	3.465	V	
Data Input Voltage Differential	IVdip-VdinI			1	V	
Control Input Voltage Differential	Vi	-0.3		Vcc+0.5	V	
Control Output Current	Io	-20		20	mA	
Instantaneous Peak Current at Hot Plug	Icc_IP			6600	mA	
Sustained Peak Current at Hot Plug	Icc_SP			5494.5	mA	
Control Input Voltage - High	VIH	Vcc*0.7		Vcc+0.3	V	
Control Input Voltage - Low	VIL	-0.3		Vcc*0.3	V	
2-Wire Serial Interface Clock Rate				400	kHz	
Power Supply Noise (1kHz to 1MHz Pk-Pk)				66	mVp-p	
<b>Transmitter</b>						
Differential Pk-Pk Input Voltage Tolerance (TP1a)		750			mV	
Pk-Pk AC Common-Mode Voltage Tolerance	Low-Frequency (VCMLF)			32	mV	
	Full-Band (VCMFB)			80		
Differential-Mode to Common-Mode Return Loss	RLcd		802.3ck 120G-2		dB	
Effective Return Loss	ERL	8.5			dB	
Differential Termination Mismatch				10	%	
Single-Ended Voltage Tolerance Range		-0.4		3.3	V	
DC Common-Mode Voltage Tolerance		-0.35		2.85	V	
<b>Receiver</b>						
Pk-Pk AC Common-Mode Voltage	Low-Frequency (VCMLF)			32	mV	
	Full-Band (VCMFB)			80		

Differential Pk-Pk Output Voltage	Short-Mode				600	mV	
	Long-Mode				845		
Eye Height	EH	15				mV	
Vertical Eye Closure	VEC				12	dB	
Common-Mode to Differential-Mode Return Loss	RLDc	802.3ck 120G-1				dB	
Effective Return Loss	ERL	8.5				dB	
Differential Termination Mismatch					10	%	
Transition Time		8.5				ps	
DC Common-Mode Voltage Tolerance		-0.35			2.85	V	
<b>Low-Speed Control and Sense Signals</b>							
Module Output SCL and SDA	VOL	0			0.4	V	
Module Input SCL and SDA	VIL	-0.3			Vcc*0.3	V	
	VIH	Vcc*0.7			Vcc+0.5	V	
InitMode, ResetL, and ModSelL	VIL	-0.3			0.8	V	
	VIH	2			Vcc+0.3	V	
IntL	VOL	0			0.4	V	
	VOH	Vcc-0.5			Vcc+0.3	V	

## Optical Characteristics

Parameter	Symbol	Min.	Typ.	Max.	Unit	Notes
<b>Transmitter</b>						
Wavelength L0, L4	$\lambda_{C0}, \lambda_{C4}$	1264.5	1271	1277.5	nm	
Wavelength L1, L5	$\lambda_{C1}, \lambda_{C5}$	1284.5	1291	1297.5	nm	
Wavelength L2, L6	$\lambda_{C2}, \lambda_{C6}$	1304.5	1311	1317.5	nm	
Wavelength L3, L7	$\lambda_{C3}, \lambda_{C7}$	1324.5	1331	1337.5	nm	
Side-Mode Suppression Ratio	SMSR	30			dB	
Total Average Launch Power	AOPT			10.4	dBm	
Average Launch Power Per Lane	AOPL	-3.2		4.4	dBm	1
Outer Optical Modulation Amplitude (OMA <sub>outer</sub> ) Per Lane	TDECQ < 1.4dB	TOMA	-0.2		3.7	dBm
	1.4dB ≤ TDECQ ≤ 3.4dB		-1.6+TDECQ			
Difference in Launch Power Between Any Two Lanes (OMA <sub>outer</sub> )	AOPd			3.9	dB	
Transmitter and Dispersion Eye Closure for PAM4 (TDECQ) Per Lane	TDECQ			3.4	dB	
Transmitter Eye Closure for PAM4 (TECQ) Per Lane	TECQ			3.4	dB	
TDECQ – TECQ				2.5	dB	
Overshoot/Undershoot				22	%	

<b>Transmitter Power Excursion</b>					1.8	dBm	
<b>Average Launch Power of Off Transmitter Per Lane</b>		Toff			-16	dBm	
<b>Extinction Ratio</b>		ER	3.5			dB	
<b>Transmitter Transition Time (Maximum)</b>		Tr			17	ps	
<b>RIN<sub>17.1</sub>OMA (Maximum)</b>		RIN			-136	dB/Hz	
<b>Optical Return Loss Tolerance</b>		ORL			17.1	dB	
<b>Transmitter Reflectance</b>		TR			-26	dB	2
<b>Receiver</b>							
<b>Wavelength L0, L4</b>		λC0, λC4	1264.5	1271	1277.5	nm	
<b>Wavelength L1, L5</b>		λC1, λC5	1284.5	1291	1297.5	nm	
<b>Wavelength L2, L6</b>		λC2, λC6	1304.5	1311	1317.5	nm	
<b>Wavelength L3, L7</b>		λC3, λC7	1324.5	1331	1337.5	nm	
<b>Damage Threshold Per Lane</b>		AOPD	5.4			dBm	
<b>Average Receive Power Per Lane</b>		AOPR	-7.2		4.4	dBm	
<b>Receive Power (OMAouter) Per Lane</b>		OMAR			3.7	dBm	
<b>Difference in Receive Power Between Any Two Lanes (OMAouter) Maximum</b>		AOPg			4.1	dB	
<b>Receiver Reflectance</b>		RR			-26	dB	
<b>Receiver Sensitivity (OMAouter) Per Lane</b>	<b>TECQ&lt;1.4dB</b>	SOMA			-4.6	dBm	
	<b>1.4dB≤TECQ≤3.4dB</b>				-6+TECQ		
<b>Stressed Receiver Sensitivity (OMAouter) Per Lane</b>		SRS			-2.6	dBm	3
<b>Stressed Eye Closure for PAM4 (SECQ) Per Lane Under Test</b>				3.4		dB	
<b>OMAouter of Each Aggressor Lane</b>				1.4		dBm	

**Notes:**

1. Average launch power, per lane (minimum) is informative and not the principal indicator of signal strength.
2. Transmitter reflectance is defined looking into the transmitter.
3. Measured with conformance test signal at TP3 for the BER=2.4x10<sup>-4</sup>.

## Pin Descriptions

Pin	Logic	Symbol	Name/Description	Notes
1		GND	Module Ground.	
2	CML-I	Tx2+	Transmitter Data Non-Inverted.	
3	CML-I	Tx2-	Transmitter Data Inverted.	
4		GND	Module Ground.	
5	CML-I	Tx4+	Transmitter Data Non-Inverted.	
6	CML-I	Tx4-	Transmitter Data Inverted.	
7		GND	Module Ground.	
8	CML-I	Tx6+	Transmitter Data Non-Inverted.	
9	CML-I	Tx6-	Transmitter Data Inverted.	
10		GND	Module Ground.	
11	CML-I	Tx8+	Transmitter Data Non-Inverted.	
12	CML-I	Tx8-	Transmitter Data Inverted.	
13		GND	Module Ground.	
14	LVC MOS-I/O	SCL	2-Wire Serial Interface Clock.	
15		Vcc	+3.3V Power.	
16		Vcc	+3.3V Power.	
17	Multi-Level	LPWn/PRSn	Low-Power Mode/Module Present.	
18		GND	Module Ground.	
19	CML-O	Rx7-	Receiver Data Inverted.	
20	CML-O	Rx7+	Receiver Data Non-Inverted.	
21		GND	Module Ground.	
22	CML-O	Rx5-	Receiver Data Inverted.	
23	CML-O	Rx5+	Receiver Data Non-Inverted.	
24		GND	Module Ground.	
25	CML-O	Rx3-	Receiver Data Inverted.	
26	CML-O	Rx3+	Receiver Data Non-Inverted.	
27		GND	Module Ground.	
28	CML-O	Rx1-	Receiver Data Inverted.	
29	CML-O	Rx1+	Receiver Data Non-Inverted.	
30		GND	Module Ground.	
31		GND	Module Ground.	
32	CML-O	Rx2+	Receiver Data Non-Inverted.	
33	CML-O	Rx2-	Receiver Data Inverted.	
34		GND	Module Ground.	
35	CML-O	Rx4+	Receiver Data Non-Inverted.	
36	CML-O	Rx4-	Receiver Data Inverted.	
37		GND	Module Ground.	
38	CML-O	Rx6+	Receiver Data Non-Inverted.	
39	CML-O	Rx6-	Receiver Data Inverted.	

40		GND	Module Ground.
41	CML-O	Rx8+	Receiver Data Non-Inverted.
42	CML-O	Rx8-	Receiver Data Inverted.
43		GND	Module Ground.
44	Multi-Level	INT/RSTn	Module Interrupt/Module Reset.
45		Vcc	+3.3V Power.
46		Vcc	+3.3V Power.
47	LVCNOS-I/O	SDA	2-Wire Serial Interface Data.
48		GND	Module Ground.
49	CML-I	Tx7-	Transmitter Data Inverted.
50	CML-I	Tx7+	Transmitter Data Non-Inverted.
51		GND	Module Ground.
52	CML-I	Tx5-	Transmitter Data Inverted.
53	CML-I	Tx5+	Transmitter Data Non-Inverted.
54		GND	Module Ground.
55	CML-I	Tx3-	Transmitter Data Inverted.
56	CML-I	Tx3+	Transmitter Data Non-Inverted.
57		GND	Module Ground.
58	CML-I	Tx1-	Transmitter Data Inverted.
59	CML-I	Tx1+	Transmitter Data Non-Inverted.
60		GND	Module Ground.

### Electrical Pad Layout

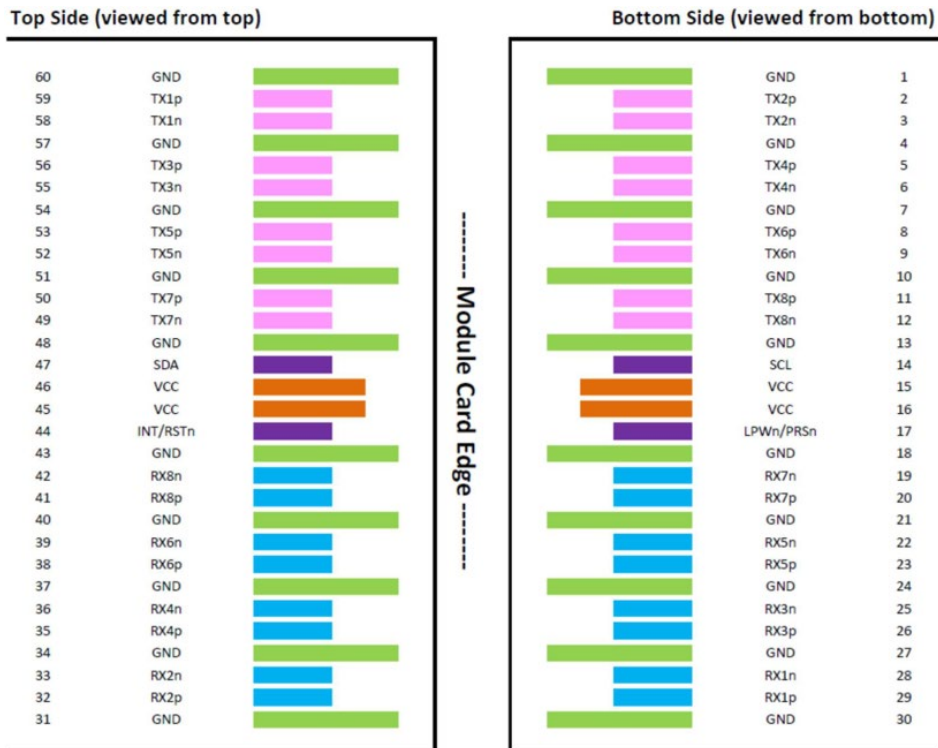

# Recommended Host Board Schematic

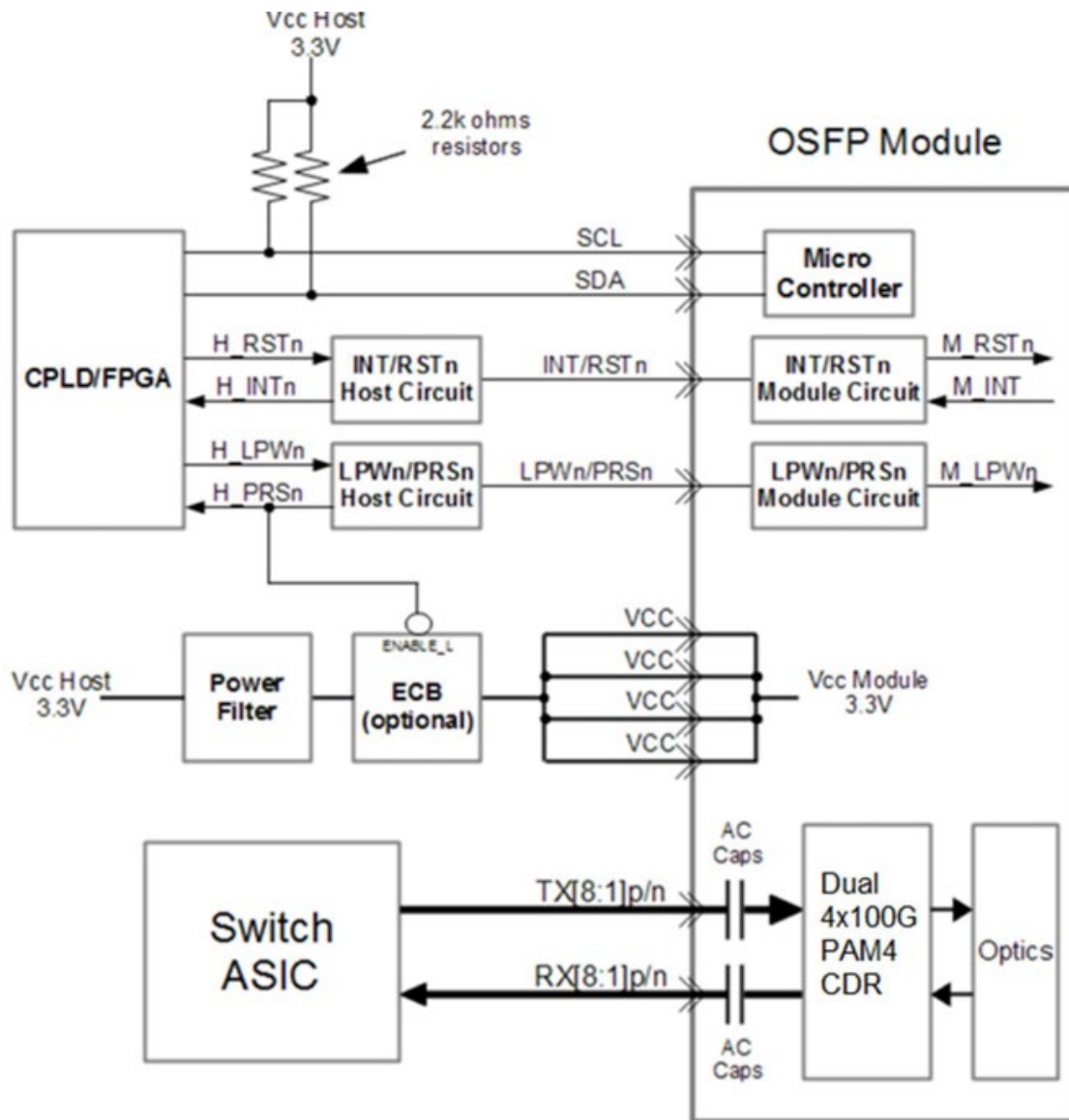

# Mechanical Specifications

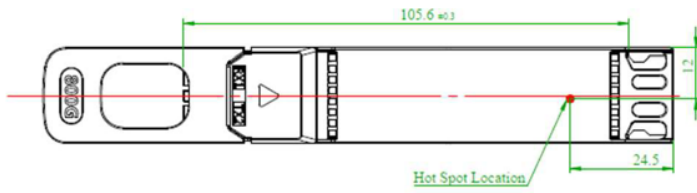
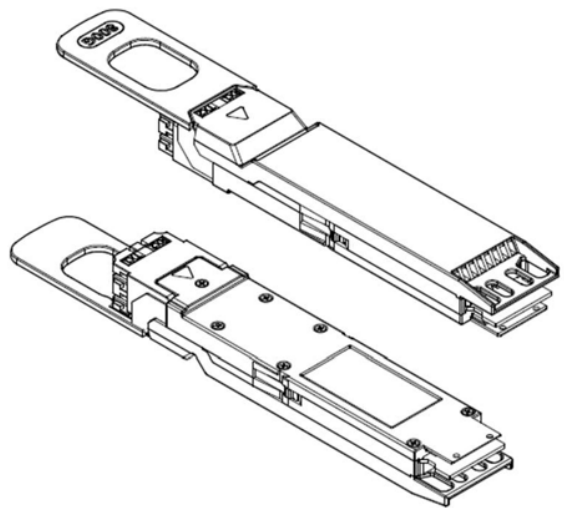
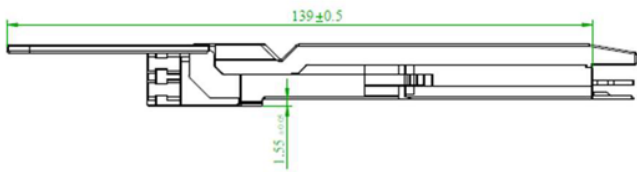
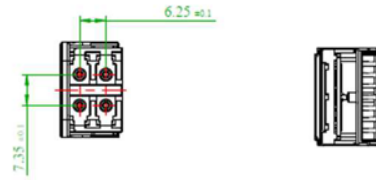
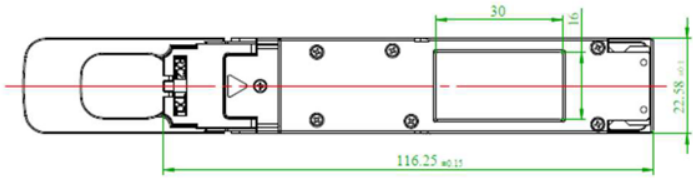
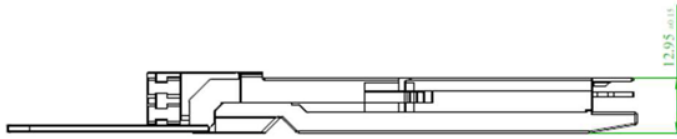

## About AddOn Networks

In 1999, AddOn Networks entered the market with a single product. Our founders fulfilled a severe shortage for compatible, cost-effective optical transceivers that compete at the same performance levels as leading OEM manufacturers. Adhering to the idea of redefining service and product quality not previously had in the fiber optic networking industry, AddOn invested resources in solution design, production, fulfillment, and global support.

Combining one of the most extensive and stringent testing processes in the industry, an exceptional free tech support center, and a consistent roll-out of innovative technologies, AddOn has continually set industry standards of quality and reliability throughout its history.

Reliability is the cornerstone of any optical fiber network and is ingrained in AddOn's DNA. It has played a key role in nurturing the long-term relationships developed over the years with customers. AddOn remains committed to exceeding industry standards with certifications ranging from NEBS Level 3 to ISO 9001:2015 with every new development while maintaining the signature reliability of its products.



## U.S. Headquarters

Email: [sales@addonnetworks.com](mailto:sales@addonnetworks.com)

Telephone: +1 877.292.1701

Fax: 949.266.9273

## Europe Headquarters

Email: [salesemea@addonnetworks.com](mailto:salesemea@addonnetworks.com)

Telephone: +44 1285 842070