

MC2207312-020--C

Mellanox® MC2207312-020 Compatible TAA Compliant 56GBase-AOC QSFP+ Active Optical Cable (850nm, MMF, 20m)

Features

- Support Infiniband and Fibre Channel application
- Compliant to QSFP+ Electrical MSA SFF-8436
- Multi rate of up to 14.025 Gbps
- +3.3V single power supply
- Low power consumption
- Operating case temp Commercial: 0°C to +70°C
- RoHS compliant
- 20m length



Applications

- InfiniBand FDR at 56Gb
- 16G Fibre Channel at 14Gb per lane
- Super Computer
- Other optical links

Product Description

This is a Mellanox® MC2207312-020 compatible 56GBase-AOC QSFP+ to QSFP+ active optical cable that operates over multi-mode fiber with a maximum reach of 20.0m (65.6ft). At a wavelength of 850nm, it has been programmed, uniquely serialized, and data-traffic and application tested to ensure it is 100% compliant and functional. This active optical cable is TAA (Trade Agreements Act) compliant, and is built to comply with MSA (Multi-Source Agreement) standards. We stand behind the quality of our products and proudly offer a limited lifetime warranty.

ProLabs' active optical cables are RoHS compliant and lead-free.

TAA refers to the Trade Agreements Act (19 U.S.C. & 2501-2581), which is intended to foster fair and open international trade. TAA requires that the U.S. Government may acquire only "U.S. – made or designated country end products."



Absolute Maximum Ratings

Parameter	Symbol	Min.	Typ.	Max.	Unit	Notes
Power Supply Voltage	V _{cc}	-0.5		3.6	V	
Operating Case Temperature	T _c	0		70	°C	
Storage Temperature	T _{stg}	-10		70	°C	
Operating Humidity	RH	+5		85	%	1

Notes:

1. No condensation.

Electrical Characteristics

Parameter	Symbol	Min.	Typ.	Max.	Unit	Notes
Power Supply Voltage	V _{cc}	3.14	3.3	3.47	V	
Power Dissipation	P _D			1.5	W	
Bit Rate	BR	1.25	14.025		Gbps	
ModSelL	Module Select	VOL	0	0.8	V	
	Module Unselect	VOH	2.5	V _{cc}	V	
LPMode	Low-Power Mode	VIL	0	0.8	V	
	Normal Operation	VIH	2.5	V _{cc} +0.3	V	
ResetL	Reset	VIL	0	0.8	V	
	Normal Operation	VIH	2.5	V _{cc} +0.3	V	
ModPrsL	Normal Operation	VOL	0	0.4	V	
IntL	Interrupt	VOL	0	0.4	V	
	Normal Operation	VOH	2.4	V _{cc}	V	
Electrical Transmitter Characteristics						
Differential Data Input Swing	V _{IN,pp}	200		1600	mVp-p	
Differential Input Impedance	Z _{IN}	90	100	120	Ω	
Receiver						
Differential Data Output Swing	V _{IN,pp}	350		800	mVp-p	
Bit Error Rate	BER			E-12		1
Differential Input Impedance	Z _{IN}	90	100	110	Ω	

Notes:

1. PRBS=2³¹-1@14.025Gbps.

Pin Descriptions

Pin	Symbol	Name/Descriptions	Ref.
1	GND	Module Ground.	1
2	Tx2-	Transmitter Inverted Data Input.	
3	Tx2+	Transmitter Non-Inverted Data Input.	
4	GND	Module Ground.	1
5	Tx4-	Transmitter Inverted Data Input.	
6	Tx4+	Transmitter Non-Inverted Data Input.	
7	GND	Module Ground.	1
8	ModSelL	Module Select.	
9	ResetL	Module Reset.	
10	VccRx	+3.3V Power Supply Receiver.	
11	SCL	2-Wire Serial Interface Clock.	
12	SDA	2-Wire Serial Interface Data.	
13	GND	Module Ground.	1
14	Rx3+	Receiver Non-Inverted Data Output.	
15	Rx3-	Receiver Inverted Data Output.	
16	GND	Module Ground.	1
17	Rx1+	Receiver Non-Inverted Data Output.	
18	Rx1-	Receiver Inverted Data Output.	
19	GND	Module Ground.	1
20	GND	Module Ground.	1
21	Rx2-	Receiver Inverted Data Output.	
22	Rx2+	Receiver Non-Inverted Data Output.	
23	GND	Module Ground.	1
24	Rx4-	Receiver Inverted Data Output.	
25	Rx4+	Receiver Non-Inverted Data Output.	
26	GND	Module Ground.	1
27	ModPrsL	Module Present.	
28	IntL	Interrupt.	
29	VccTx	+3.3V Power Supply Transmitter.	
30	Vcc1	+3.3V Power Supply.	
31	LPMODE	Low-Power Mode.	
32	GND	Module Ground.	1
33	Tx3+	Transmitter Non-Inverted Data Input.	
34	Tx3-	Transmitter Inverted Data Input.	
35	GND	Module Ground.	1
36	Tx1+	Transmitter Non-Inverted Data Input.	
37	Tx1-	Transmitter Inverted Data Input.	
38	GND	Module Ground.	1

Notes:

1. Circuit ground is internally isolated from the chassis ground.

Electrical Pin-Out Details

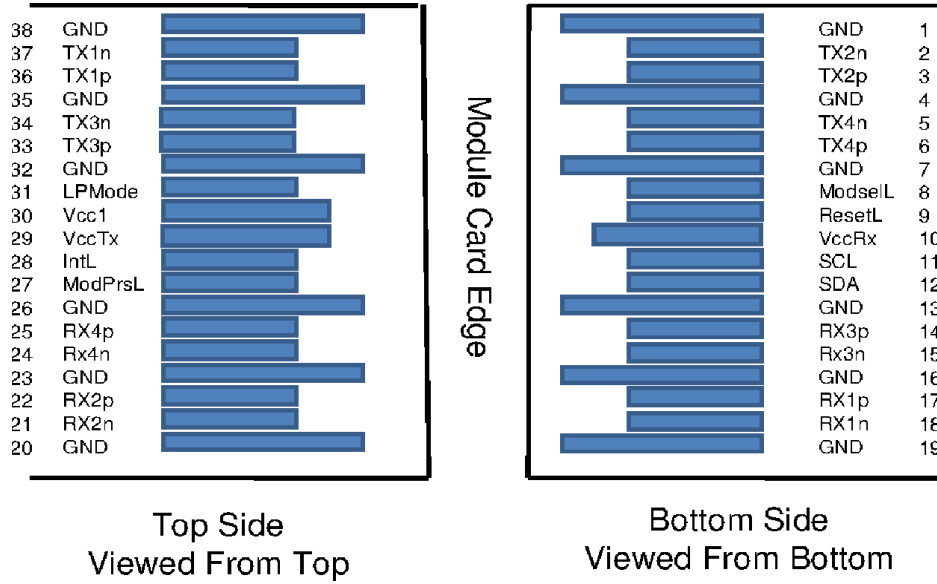

Recommended Interface Circuit

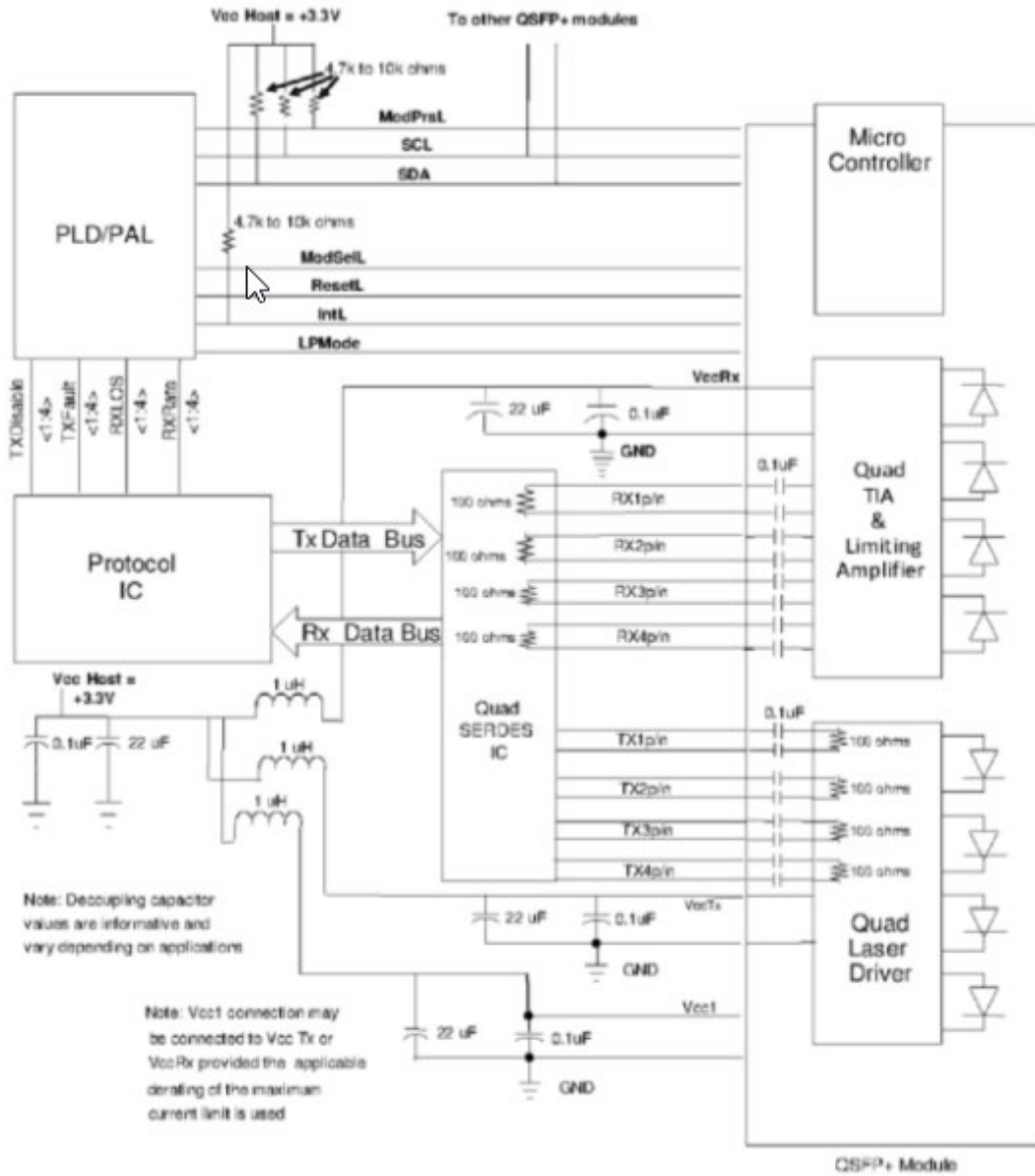

Monitoring Specifications

2-Wire Serial Address 1010000x	
Lower Page 00h	
0	Identifier
1- 2	Status
3- 21	Interrupt Flags
22- 33	Free Side Device Monitors
34- 81	Channel Monitors
82- 85	Reserved
86- 98	Control
99	Reserved
100-104	Hardware Interrupt Pin Masks
105-106	Vendor Specific
107	Reserved
108-110	Free Side Device Properties
111-112	Assigned for use by PCI Express
113	Free Side Device Properties
114-118	Reserved
119-122	Password Change Entry Area (Optional)
123-126	Password Entry Area (Optional)
127	Page Select Byte

Upper Page 00h	Optional Page 01h	Optional Page 02h	Optional Page 03h
128 Identifier	128 CC_APPS	128-255 User EEPROM Data	128-175 Free Side Device Thresholds
129-191 Base ID Fields	129 AST Table Length (TL)		176-223 Channel Thresholds
	130-131 Application Code Entry 0		
	132-133 Application Code Entry 1		
	134-253 other entries		
192-223 Extended ID		224 Tx EQ & Rx Emphasis Magnitude ID	
224-255 Vendor Specific ID		225 RX output amplitude indicators	
		226-241 Channel Controls	
		242-251 Channel Monitor Masks	
	254-255 Application Code Entry TL		252-255 Reserved

Mechanical Specifications

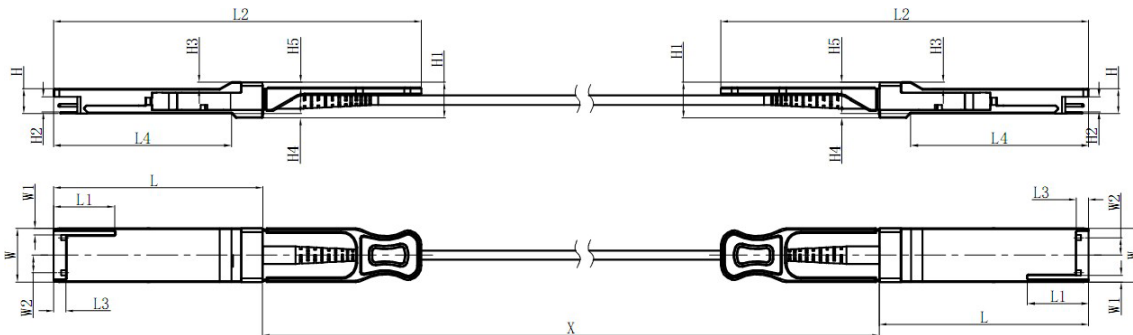

About ProLabs

Our experience comes as standard; for over 15 years ProLabs has delivered optical connectivity solutions that give our customers freedom and choice through our ability to provide seamless interoperability. At the heart of our company is the ability to provide state-of-the-art optical transport and connectivity solutions that are compatible with over 90 optical switching and transport platforms.

Complete Portfolio of Network Solutions

ProLabs is focused on innovations in optical transport and connectivity. The combination of our knowledge of optics and networking equipment enables ProLabs to be your single source for optical transport and connectivity solutions from 100Mb to 400G while providing innovative solutions that increase network efficiency. We provide the optical connectivity expertise that is compatible with and enhances your switching and transport equipment.

Trusted Partner

Customer service is our number one value. ProLabs has invested in people, labs and manufacturing capacity to ensure that you get immediate answers to your questions and compatible product when needed. With Engineering and Manufacturing offices in the U.K. and U.S. augmented by field offices throughout the U.S., U.K. and Asia, ProLabs is able to be our customers best advocate 24 hours a day.

Contact Information

ProLabs US

Email: sales@prolabs.com

Telephone: 952-852-0252

ProLabs UK

Email: salessupport@prolabs.com

Telephone: +44 1285 719 600