

MMA1L30-CM-AO

Mellanox® MMA1L30-CM Compatible TAA Compliant 100GBase-CWDM4 EDR QSFP28 Optical Transceiver Module (SMF, 1310nm, 2km, LC, DOM)

Features:

- Compliant with IEEE Std 802.3ba, 100G Ethernet
- Compliant with QSFP28 MSA
- 4 x 25Gb/s CWDM transmitter
- 4 channels PIN photo detector
- Single +3.3V power supply
- Class 1 laser safety certified
- Power consumption less than 3.5W
- Operating Temperature: -5°C to +70°C
- Up to 2km on SMF
- RoHS-6 Compliant



Applications:

- 100G CWDM4 Ethernet links
- Data center
- Infiniband EDR

Product Description

This Mellanox® MMA1L30-CM compatible QSFP28 transceiver provides 100GBase-CWDM4 throughput up to 2km over single-mode fiber (SMF) using wavelengths between 1270nm to 1330nm via an LC connector. It is guaranteed to be 100% compatible with the equivalent Mellanox® transceiver. This easy to install, hot swappable transceiver has been programmed, uniquely serialized and data-traffic and application tested to ensure that it will initialize and perform identically. Digital optical monitoring (DOM) support is also present to allow access to real-time operating parameters. This transceiver is Trade Agreements Act (TAA) compliant. We stand behind the quality of our products and proudly offer a limited lifetime warranty.

AddOn's transceivers are RoHS compliant and lead-free.

TAA refers to the Trade Agreements Act (19 U.S.C. & 2501-2581), which is intended to foster fair and open international trade. TAA requires that the U.S. Government may acquire only "U.S. – made or designated country end products."



Regulatory Compliance

- ESD to the Electrical PINs: compatible with MIL-STD-883E Method 3015.4
- ESD to the LC Receptacle: compatible with IEC 61000-4-3
- EMI/EMC compatible with FCC Part 15 Subpart B Rules, EN55022:2010
- Laser Eye Safety compatible with FDA 21CFR, EN60950-1& EN (IEC) 60825-1,2
- RoHS compliant with EU RoHS 2.0 directive 2015/863/EU

Absolute Maximum Ratings

Parameter	Symbol	Min.	Typ.	Max.	Unit
Maximum Supply Voltage	V _{CC}	-0.5		4.0	V
Storage Temperature	T _S	-40		85	°C
Operating Case Temperature	T _c	-5	25	70	°C
Operating Humidity	RH	5		95	%
Data Rate PER Channel			25.78125		Gbps

Electrical Characteristics

Parameter	Symbol	Min.	Typ.	Max.	Unit	Notes
Supply Voltage	V _{CC}	3.135	3.3	3.465	V	
Module Supply Current	I _{CC}			1100	mA	
Power Dissipation	P _D			3500	mW	
Transmitter						
Single-ended Input Voltage Tolerance		-0.3		4.0	V	
Input Differential Impedance	Z _{in}		100		Ω	
Differential Data Input Swing	V _{IN, P-P}	190		700	mV _{P-P}	
AC Common Mode Input Voltage Tolerance		15			mV	
Differential Input Voltage Swing Threshold		50			mV _{pp}	
Receiver						
Single-ended Output Voltage		-0.3		4.0	V	
Output Differential Impedance	Z _o	90	100	110	Ω	
Differential Data Output Swing	V _{OUT, P-P}	300		850	mV _{P-P}	
AC Common Mode Output Voltage				7.5	mV	

Optical Characteristics

Parameter	Symbol	Min.	Typ.	Max.	Unit	Notes
Transmitter						
Launch Optical Power per lane	P _o	-6.5		+2.5	dBm	1
Total Launch Optical Power	P _o			+8.5	dBm	1
Center Wavelength Range	L1	1264.5	1271	1277.5	nm	
	L2	1284.5	1291	1297.5	nm	
	L3	1304.5	1311	1317.5	nm	
	L4	1324.5	1331	1337.5	nm	
Extinction Ratio	EX	3.5			dB	2
Spectral width(-20dB)	$\Delta\lambda$			1	nm	
Side Mode Suppression Ratio	SMSR	30			dB	
Optical Return Loss Tolerance	ORLT			20	dB	
P _{out} @TX-Disable Asserted	P _{off}			-30	dBm	1
Eye Mask {X1, X2, X3, Y1, Y2, Y3}		{0.31, 0.4, 0.45, 0.34, 0.38, 0.4}				
Receiver						
Center Wavelength Range	L1	1264.5	1271	1277.5	nm	
	L2	1284.5	1291	1297.5	nm	
	L3	1304.5	1311	1317.5	nm	
	L4	1324.5	1331	1337.5	nm	
Sensitivity per Channel	S			-10.0	dBm	3
Damage Threshold (each channel)	POL	3.5			dBm	
Optical Return Loss	ORL	26			dB	
LOS De-Assert	LOSD			-11.5	dBm	
LOS Assert	LOSA	-24			dBm	
LOS Hysteresis		0.5			dB	

Notes:

1. The optical power is launched into SMF.
2. Measured with a PRBS 2³¹-1 test pattern @25.78125Gbps.
3. Measured with PRBS 2³¹-1 test pattern, 25.78125Gb/s, BER 5.0E-5

Pin Descriptions

Pin	Symbol	Name/Descriptions	Ref.
1	GND	Transmitter Ground (Common with Receiver Ground)	1
2	Tx2-	Transmitter Inverted Data Input	
3	Tx2+	Transmitter Non-Inverted Data output	
4	GND	Transmitter Ground (Common with Receiver Ground)	1
5	Tx4-	Transmitter Inverted Data Input	
6	Tx4+	Transmitter Non-Inverted Data output	
7	GND	Transmitter Ground (Common with Receiver Ground)	1
8	ModSelL	Module Select	2
9	ResetL	Module Reset	2
10	VccRx	3.3V Power Supply Receiver	
11	SCL	2-Wire serial Interface Clock	2
12	SDA	2-Wire serial Interface Data	2
13	GND	Transmitter Ground (Common with Receiver Ground)	1
14	Rx3+	Receiver Non-Inverted Data Output	
15	Rx3-	Receiver Inverted Data Output	
16	GND	Transmitter Ground (Common with Receiver Ground)	1
17	Rx1+	Receiver Non-Inverted Data Output	
18	Rx1-	Receiver Inverted Data Output	
19	GND	Transmitter Ground (Common with Receiver Ground)	1
20	GND	Transmitter Ground (Common with Receiver Ground)	1
21	Rx2-	Receiver Inverted Data Output	
22	Rx2+	Receiver Non-Inverted Data Output	
23	GND	Transmitter Ground (Common with Receiver Ground)	1
24	Rx4-	Receiver Inverted Data Output	1
25	Rx4+	Receiver Non-Inverted Data Output	
26	GND	Transmitter Ground (Common with Receiver Ground)	1
27	ModPrsl	Module Present	
28	IntL	Interrupt	2
29	VccTx	3.3V power supply transmitter	
30	Vcc1	3.3V power supply	
31	LPMODE	Low Power Mode	2
32	GND	Transmitter Ground (Common with Receiver Ground)	1
33	Tx3+	Transmitter Non-Inverted Data Input	
34	Tx3-	Transmitter Inverted Data Output	
35	GND	Transmitter Ground (Common with Receiver Ground)	1
36	Tx1+	Transmitter Non-Inverted Data Input	
37	Tx1-	Transmitter Inverted Data Output	
38	GND	Transmitter Ground (Common with Receiver Ground)	1

Notes:

1. The module signal grounds are isolated from the module case.
2. This is an open collector/drain output that on the host board requires a 4.7KΩ to 10KΩ pull-up resistor to VccHost.

Electrical Pin-out Details

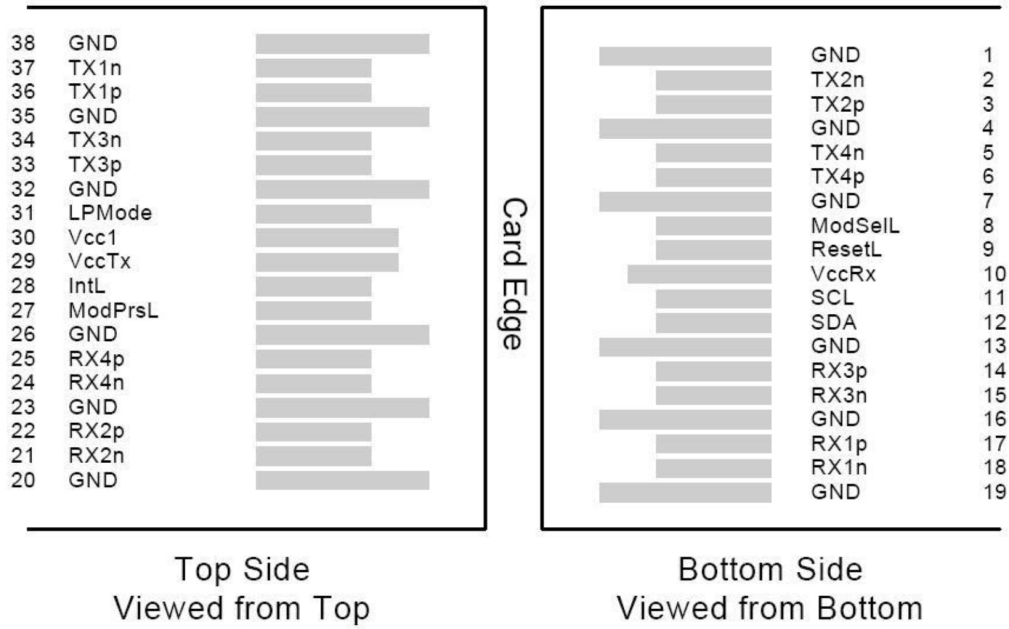

Recommended Host Board Power Supply Filter Network

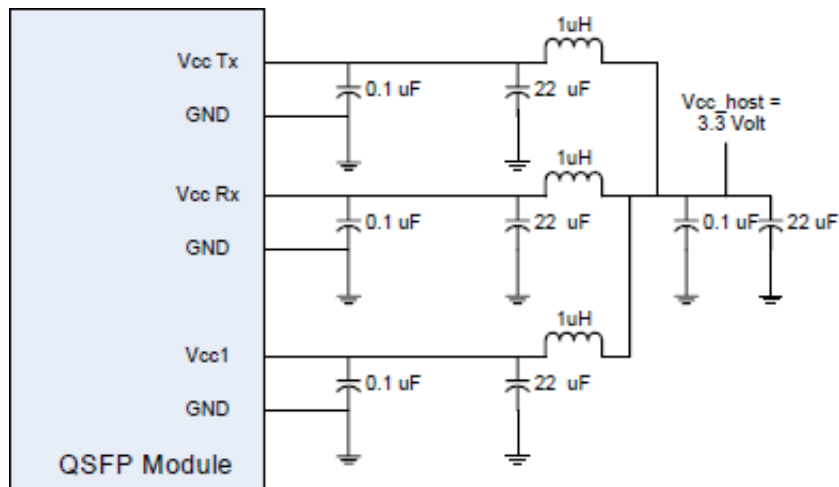

Recommended Application Interface Block Diagram

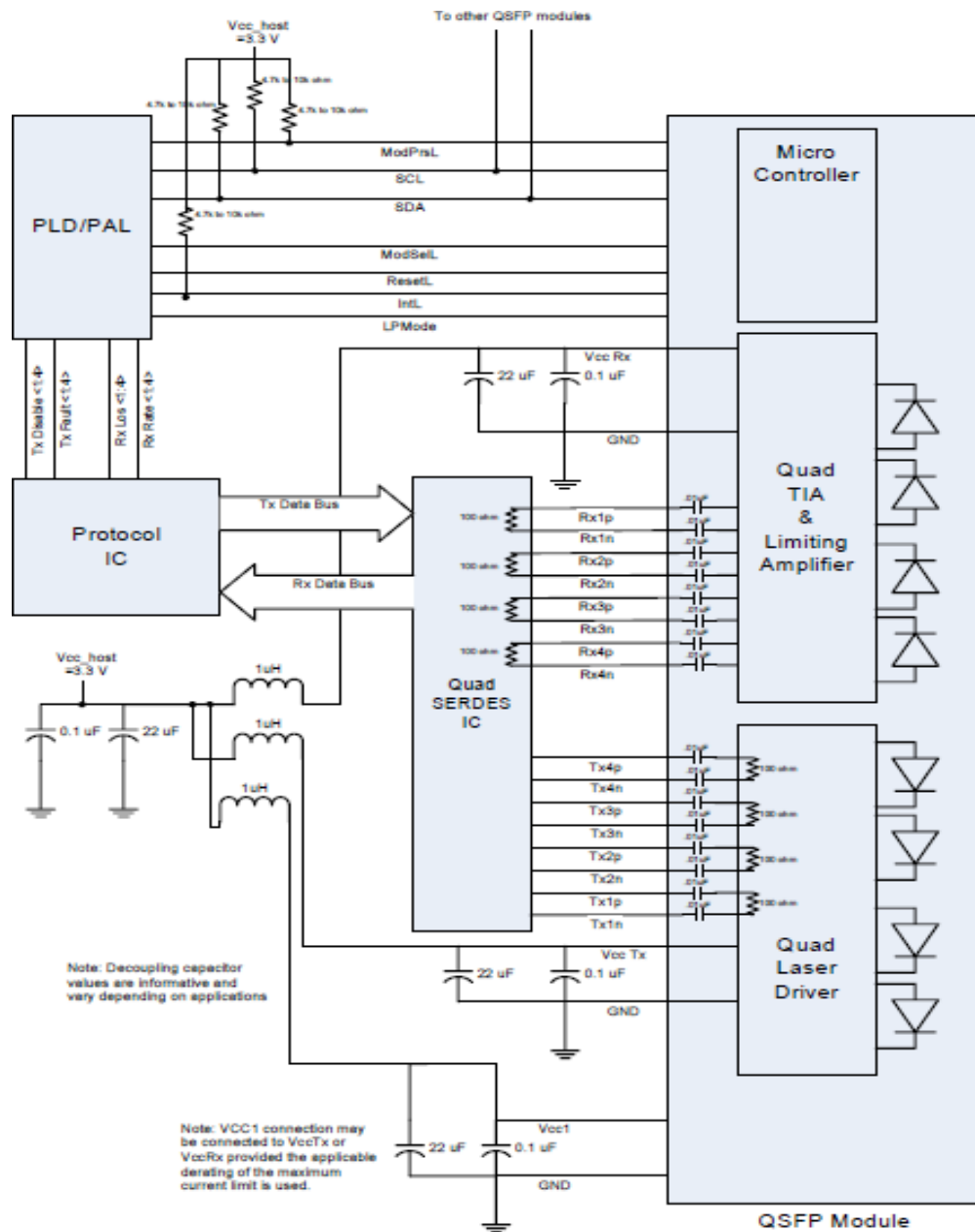

Mechanical Specifications

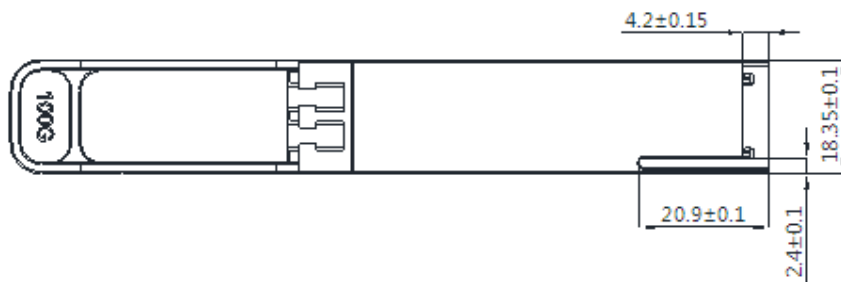
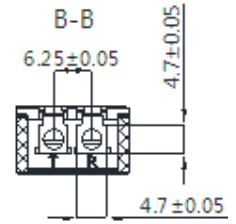
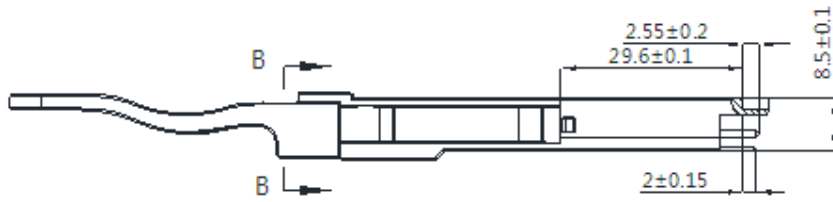
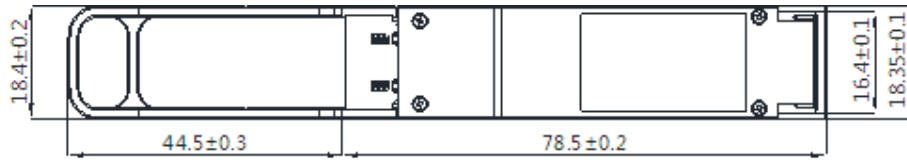

About AddOn Networks

In 1999, AddOn Networks entered the market with a single product. Our founders fulfilled a severe shortage for compatible, cost-effective optical transceivers that compete at the same performance levels as leading OEM manufacturers. Adhering to the idea of redefining service and product quality not previously had in the fiber optic networking industry, AddOn invested resources in solution design, production, fulfillment, and global support.

Combining one of the most extensive and stringent testing processes in the industry, an exceptional free tech support center, and a consistent roll-out of innovative technologies, AddOn has continually set industry standards of quality and reliability throughout its history.

Reliability is the cornerstone of any optical fiber network and is engrained in AddOn's DNA. It has played a key role in nurturing the long-term relationships developed over the years with customers. AddOn remains committed to exceeding industry standards with certifications from ranging from NEBS Level 3 to ISO 9001:2005 with every new development while maintaining the signature reliability of its products.

U.S. Headquarters

Email: sales@addonnetworks.com

Telephone: +1 877.292.1701

Fax: 949.266.9273

Europe Headquarters

Email: salesupportemea@addonnetworks.com

Telephone: +44 1285 842070