

MC2207310-100-AO

Mellanox® MC2207310-100 Compatible TAA Compliant 56GBase-AOC QSFP+ Active Optical Cable (850nm, MMF, 100m)

Features

- Complies with QSFP MSA high- density form factor
- Four-channel full-duplex active optical cable
- Multi-rate capability: 1.06Gbps to 14.025Gbps per channel
- Round, riser-rated (OFNR)
- Built-in digital diagnostic functions
- Single 3.3V power supply
- Commercial Temperature 0 to 70 Celsius
- Hot Pluggable
- RoHS Compliant and Lead-Free
- Metal with lower EMI



Applications

- x

Product Description

This is a Mellanox® MC2207310-100 compatible 56GBase-AOC QSFP+ to QSFP+ active optical cable that operates over multi-mode fiber with a maximum reach of 100.0m (328.1ft). At a wavelength of 850nm, it has been programmed, uniquely serialized, and data-traffic and application tested to ensure it is 100% compliant and functional. This active optical cable is TAA (Trade Agreements Act) compliant, and is built to comply with MSA (Multi-Source Agreement) standards. We stand behind the quality of our products and proudly offer a limited lifetime warranty.

AddOn's transceivers are RoHS compliant and lead-free.

TAA refers to the Trade Agreements Act (19 U.S.C. & 2501-2581), which is intended to foster fair and open international trade. TAA requires that the U.S. Government may acquire only "U.S.-made or designated country end products."



General Specifications

Parameter	Symbol	Min.	Typ.	Max.	Unit
Supply Voltage	Vcc	3.13	3.3	3.47	V
Storage Temperature	Tstg	-20		+85	°C
Operating Case Temperature	Tc	0		70	°C
Data Rate per Channel	DR	1		14.0645	Gbps
Bit Error Rate	BER			<10 ⁻¹²	
Data Speed Tolerance	ΔDR	-100		100	ppm
Link Distance with OM3 fiber	D	0		100	m

Electrical Specifications

Parameter	Symbol	Min.	Typ.	Max.	Unit	Notes
Power Supply Voltage	Vcc	3.13	3.3	3.47	V	
Power Consumption		-		1.5	W	
Supply Current			230		mA	Per End Typical
Differential Input Impedance	ZIN	90	100	110	Ω	
Differential Output Impedance	ZOUT	90	100	110	Ω	
Differential Input Voltage Amplitude	ΔVIN	300		1100	mVp-p	
Differential Output Voltage Amplitude	ΔVOUT	500		800	mVp-p	
Bit Error Rate	BR			E-12		
Input Logic Level - High	VIH	2.0		Vcc	V	
Input Logic Level - Low	VIL	0		0.8	V	
Output Logic Level - High	VOH	Vcc-0.5		Vcc	V	
Output Logic Level - Low	VOL	0		0.4	V	

Pin Descriptions

Pin	Logic	Symbol	Name/Description	Note
1		GND	Module Ground.	1
2	CML-I	Tx2n	Transmitter Inverted Data Input.	
3	CML-I	Tx2p	Transmitter Non-Inverted Data Output.	
4		GND	Module Ground.	1
5	CML-I	Tx4n	Transmitter Inverted Data Input.	
6	CML-I	Tx4p	Transmitter Non-Inverted Data Output.	
7		GND	Module Ground.	1
8	LVTTLL-I	ModSelL	Module Select.	
9	LVTTLL-I	ResetL	Module Reset.	
10		VccRx	+ 3.3V Receiver Power Supply.	2
11	LVCNOS-I/O	SCL	2-Wire Serial Interface Clock.	
12	LVCNOS-I/O	SDA	2-Wire Serial Interface Data.	
13		GND	Module Ground.	
14	CML-O	Rx3p	Receiver Non-Inverted Data Output.	
15	CML-O	Rx3n	Receiver Inverted Data Output.	
16		GND	Module Ground.	1
17	CML-O	Rx1p	Receiver Non-Inverted Data Output.	
18	CML-O	Rx1n	Receiver Inverted Data Output.	
19		GND	Module Ground.	1
20		GND	Module Ground.	1
21	CML-O	Rx2n	Receiver Inverted Data Output.	
22	CML-O	Rx2p	Receiver Non-Inverted Data Output.	
23		GND	Module Ground.	1
24	CML-O	Rx4n	Receiver Inverted Data Output.	1
25	CML-O	Rx4p	Receiver Non-Inverted Data Output.	
26		GND	Module Ground.	1
27	LVTTLL-O	ModPrsL	Module Present.	
28	LVTTLL-O	IntL	Interrupt.	
29		VccTx	+3.3 V Transmitter Power Supply.	2
30		Vcc1	+3.3 V Power Supply.	2
31	LVTTLL-I	LPMODE	Low-Power Mode.	
32		GND	Module Ground.	1
33	CML-I	Tx3p	Transmitter Non-Inverted Data Input.	
34	CML-I	Tx3n	Transmitter Inverted Data Output.	
35		GND	Module Ground.	1
36	CML-I	Tx1p	Transmitter Non-Inverted Data Input.	
37	CML-I	Tx1n	Transmitter Inverted Data Output.	
38		GND	Module Ground.	1

Notes:

1. Module circuit ground is isolated from module chassis ground within the module. GND is the symbol for signal and supply (power) common for QSFP modules.
2. The connector pins are each rated for a maximum current of 500mA.

Electrical Pin-Out Details

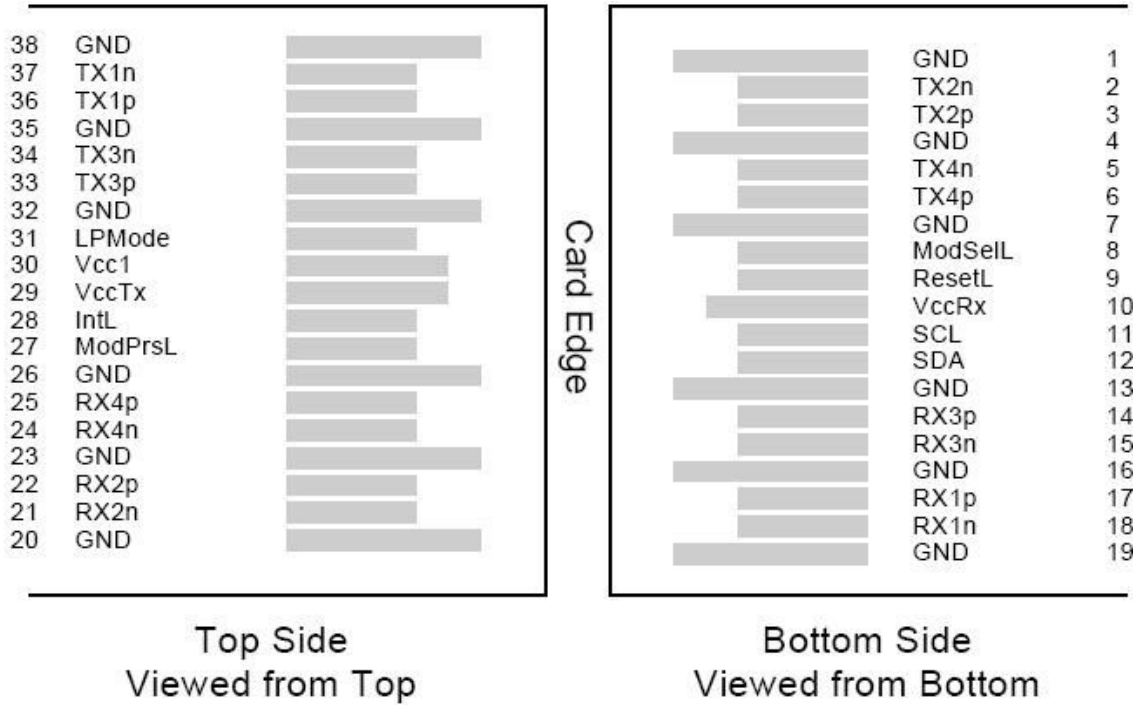

Power Supply Filtering

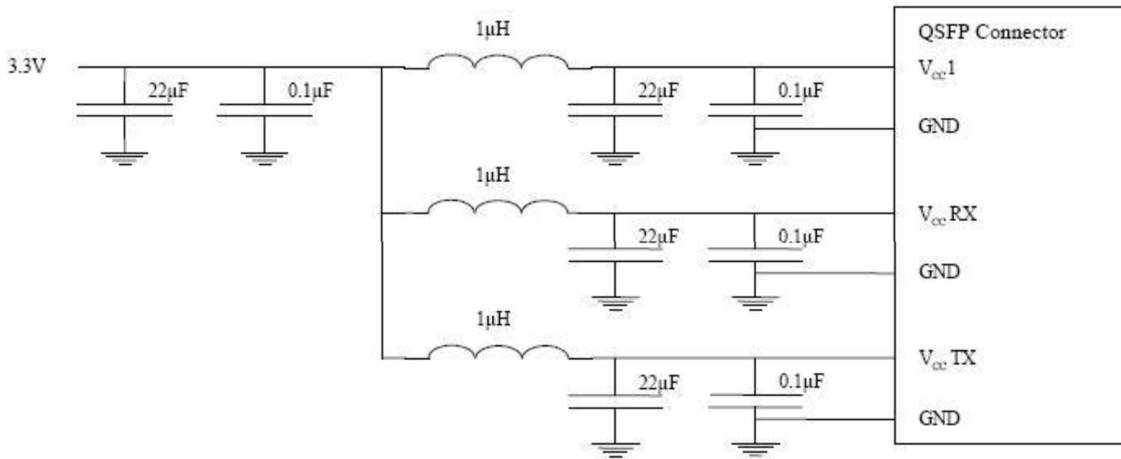

Mechanical Specifications

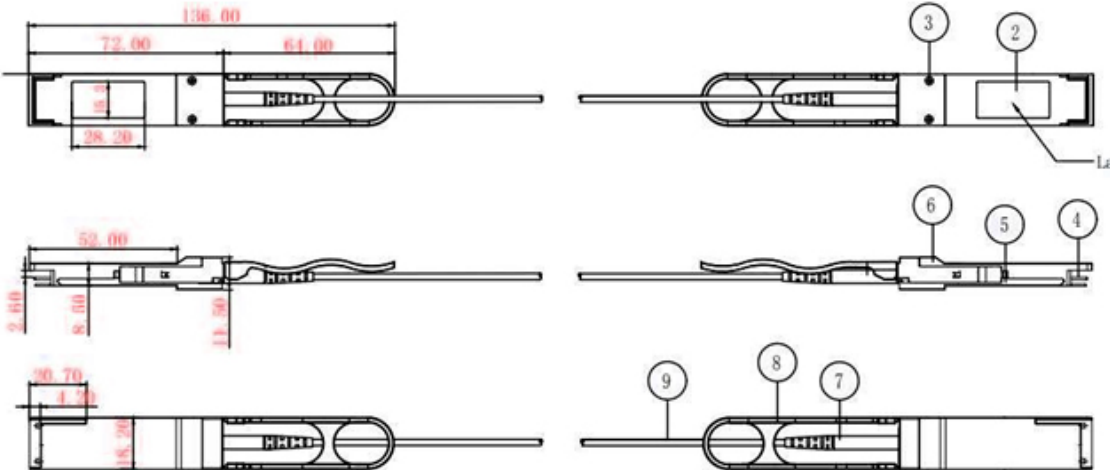

About AddOn Networks

In 1999, AddOn Networks entered the market with a single product. Our founders fulfilled a severe shortage for compatible, cost-effective optical transceivers that compete at the same performance levels as leading OEM manufacturers. Adhering to the idea of redefining service and product quality not previously had in the fiber optic networking industry, AddOn invested resources in solution design, production, fulfillment, and global support.

Combining one of the most extensive and stringent testing processes in the industry, an exceptional free tech support center, and a consistent roll-out of innovative technologies, AddOn has continually set industry standards of quality and reliability throughout its history.

Reliability is the cornerstone of any optical fiber network and is ingrained in AddOn's DNA. It has played a key role in nurturing the long-term relationships developed over the years with customers. AddOn remains committed to exceeding industry standards with certifications ranging from NEBS Level 3 to ISO 9001:2015 with every new development while maintaining the signature reliability of its products.



U.S. Headquarters

Email: sales@addonnetworks.com

Telephone: +1 877.292.1701

Fax: 949.266.9273

Europe Headquarters

Email: salesemea@addonnetworks.com

Telephone: +44 1285 842070