

## 1061003029-C

ADVA® 1061003029 Compatible TAA 1000Base-BX SFP Transceiver (SMF, 1570nmTx/1490nmRx, 80km, SC, DOM)

### Features:

- SFF-8472 and MSA Compliant
- Up to 1.25Gbps data links
- Simplex SC Connector
- Single-mode fiber
- CWDM DFB and APD-TIA with 26dB power budget
- Single 3.3V power supply and TTL logic interface
- Commercial Temperature 0 to 70 Celsius
- Support Hot Pluggable
- Metal with lower EMI
- RoHS compliant and Lead Free



### Applications:

- 1000Base Ethernet

### Product Description

This ADVA® 1061003029 compatible SFP transceiver provides 1000Base-BX throughput up to 80km over single-mode fiber (SMF) using a wavelength of 1570nmTx/1490nmRx via an SC connector. This bidirectional unit must be used with another transceiver or network appliance of complementing wavelengths. It is guaranteed to be 100% compatible with the equivalent ADVA® transceiver. This easy to install, hot swappable transceiver has been programmed, uniquely serialized and data-traffic and application tested to ensure that it will initialize and perform identically. Digital optical monitoring (DOM) support is also present to allow access to real-time operating parameters. This transceiver is Trade Agreements Act (TAA) compliant. We stand behind the quality of our products and proudly offer a limited lifetime warranty.

ProLabs' transceivers are RoHS compliant and lead-free.

TAA refers to the Trade Agreements Act (19 U.S.C. & 2501-2581), which is intended to foster fair and open international trade. TAA requires that the U.S. Government may acquire only "U.S.-made or designated country end products."



## Absolute Maximum Ratings

Parameter	Symbol	Min.	Typ.	Max.	Unit
Power Supply Voltage	Vcc	-0.5		3.6	V
Storage Temperature	Tstg	-40		85	°C
Operating Case Temperature	Tc	0		70	°C
Operating Relative Humidity				95	%
Data Rate	FE		100		Mbps
	FC		1.063		Gbps
	GBE		1.25		Gbps

### Notes:

1. Exceeding any one of these values may destroy the device immediately.

## Electrical Characteristics

Parameter	Symbol	Min.	Typ.	Max.	Unit	Notes
Power Supply Voltage	Vcc	3.15	3.3	3.45	V	
Power Supply Current	Icc			300	mA	
<b>Transmitter</b>						
LVPECL Differential Inputs	VIN	400		2000	mVp-p	1
Input Differential Impedance	ZIN	85	100	115	Ω	2
Tx_Disable	Disable	2		Vcc	V	
	Enable	0		0.8	V	
Tx_Fault	Fault	2		Vcc+0.3	V	
	Normal	0		0.5	V	
<b>Receiver</b>						
LVPECL Differential Outputs	VOUT	370		2000	mVp-p	3
Output Differential Impedance	ZOUT	85	100	115	Ω	
Rx_LOS	LOS	2		Vcc+0.3	V	
	Normal	0		0.8	V	
MOD_DEF(0:2)	VOH	2.5			V	4
	VOL	0		0.5	V	4

### Notes:

1. LVPECL logic. Internally AC coupled inputs.
2. RIN>100kΩ @DC.
3. LVPECL logic. Internally AC coupled outputs.
4. With serial ID.

## Optical Characteristics

Parameter	Symbol	Min.	Typ.	Max.	Unit	Notes
Power Budget		26			dB	
Data Rate		100		1250	Mbps	
<b>Transmitter</b>						
Channel Center Wavelength		1564	1570	1577.5	nm	1
Spectral Width (-20dB)	$\Delta\lambda$			1	nm	
Side-Mode Suppression Ratio	SMSR	30			dB	
Average Output Power	POUT	0		5	dBm	2
Extinction Ratio	ER	9			dB	3
Rise/Fall Time (20-80%)	Tr/Tf			2	ns	
Output Optical Eye		Compliant with IEEE 802.3ah-2004				3, 4
Tx_Disable Assert Time	T_off			10	us	
<b>Receiver</b>						
Channel Center Wavelength		1470	1490	1510	nm	1
Receiver Sensitivity	Pmin			-26	dBm	5
Receiver Overload	Pmax	-3			dBm	
Return Loss		12			dB	
Optical Path Penalty				1	dB	
LOS De-Assert	LOSD			-27	dBm	
LOS Assert	LOSA	-42			dBm	
LOS Hysteresis		0.5			dB	6

### Notes:

1. The channel center wavelength of the transmitter and receiver sides are typical wavelengths of CWDM channels  $\pm 20\text{nm}$ .
2. Output is coupled into a  $9/125\mu\text{m}$  single-mode fiber.
3. Filtered. Measured with a PRBS  $2^7-1$  test pattern @1250Mbps.
4. Eye pattern mask:

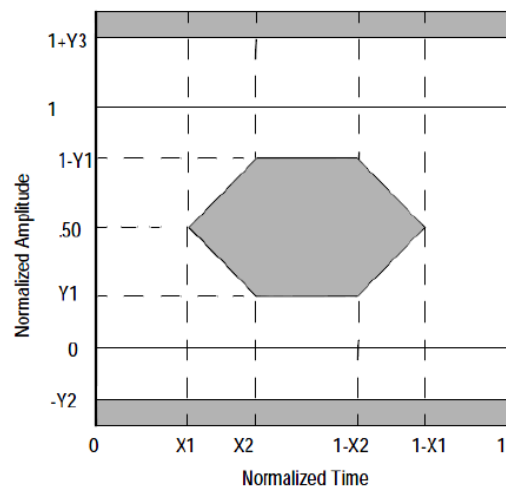

5. Measured at all data rates specified above with ER=9dB, 2<sup>7</sup>-1 PRBS data pattern, and BER<1E<sup>-12</sup>.
6. LOS Hysteresis:

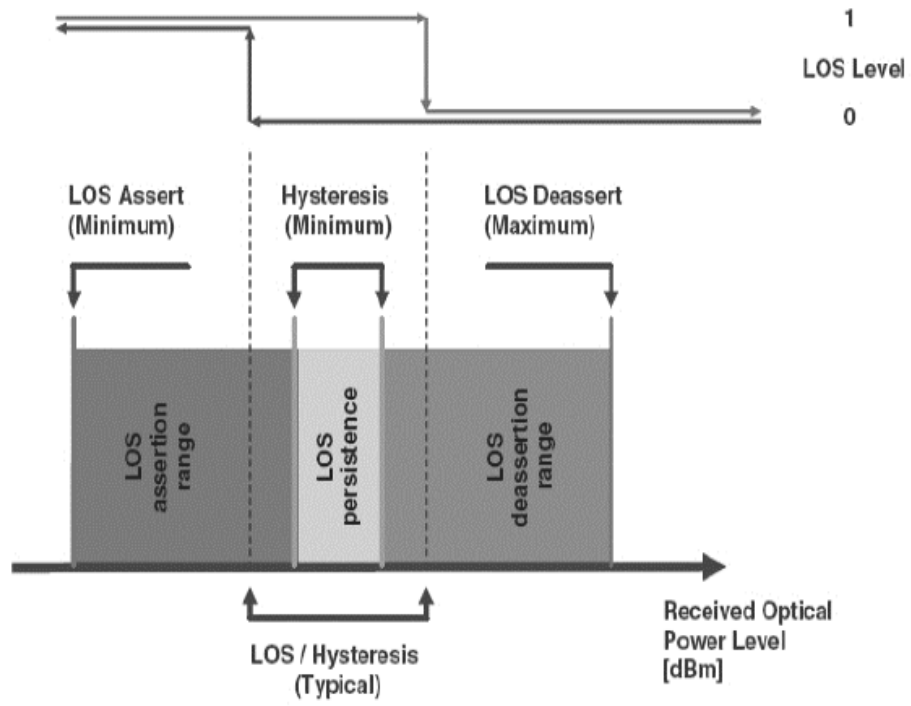

## Pin Descriptions

Pin	Symbol	Name/Description	Plug Sequence	Notes
1	VeeT	Transmitter Ground.	1	5
2	Tx_Fault	Transmitter Fault Indication.	3	1
3	Tx_Disable	Transmitter Disable. Module Disables on "High" or "Open."	3	2
4	MOD-DEF2	Module Definition 2. 2-Wire Serial Interface Data.	3	3
5	MOD-DEF1	Module Definition 1. 2-Wire Serial Interface Clock.	3	3
6	MOD-DEF0	Module Definition 0. Grounded Within the Module.	3	3
7	Rate Select	Not Connected.	3	9
8	LOS	Loss of Signal.	3	4
9	VeeR	Receiver Ground.	1	5
10	VeeR	Receiver Ground.	1	5
11	VeeR	Receiver Ground.	1	5
12	RD-	Inverted Received Data Out.	3	6
13	RD+	Received Data Out.	3	7
14	VeeR	Receiver Ground.	1	5
15	VccR	Receiver Power. 3.3±5%.	2	7
16	VccT	Transmitter Power. 3.3±5%.	2	7
17	VeeT	Transmitter Ground.	1	5
18	TD+	Transmit Data In.	3	8
19	TD-	Inverted Transmit Data In.	3	8
20	VeeT	Transmitter Ground.	1	5

### Notes:

1. Tx\_Fault is an open collector/drain output which should be pulled up with a 4.7kΩ to 10kΩ resistor on the host board. Pull-up voltage is between 2.0V and  $V_{ccT}/R+0.3V$ . When "high," the output indicates a laser fault of some kind. "Low" indicates normal operation. In the "low" state, the output will be pulled to <0.8V.
2. Tx\_Disable is an input that is used to shut down the transmitter optical output. It is pulled up in the module with a 4.7kΩ to 10kΩ resistor. Its states are:
  - Low (0V-0.8V): Transmitter On
  - (>0.8V, <2.0V): Undefined
  - High (2.0V-3.465V): Transmitter Disabled
  - Open: Transmitter Disabled.
3. MOD-DEF0, 1, and 2. These are the module definition pins. They should be pulled up with a 4.7kΩ to 10kΩ resistor on the host board. The pull-up voltage shall be VccT or VccR.
  - MOD-DEF0 is grounded by the module to indicate that the module is present.
  - MOD-DEF1 is the clock line of the 2-wire serial interface for serial ID.
  - MOD-DEF2 is the data line of the 2-wire serial interface for serial ID.

4. LOS (Loss of Signal) is an open collector/drain output which should be pulled up with a 4.7kΩ to 10kΩ resistor. Pull-up voltage is between 2.0V and  $V_{ccT}/R+0.3V$ . When “high,” this output indicates that the received optical power is below the worst-case receiver sensitivity (as defined by the standard in use). “Low” indicates normal operation. In the “low” state, the output will be pulled to <0.8V.
5. VeeR and VeeT may be internally connected within the SFP module.
6. RD±: these are the differential receiver outputs. They are AC coupled 100Ω differential lines which should be terminated with 100Ω (differential) at the user SERDES. The AC coupling is done inside the module and is thus not required on the host board. The voltage swing on these lines will be between 370mV and 2000mV differential (185mV to 1000mV single-ended) when properly terminated.
7. VccR and VccT are the receiver and transmitter power supplies. They are defined as 3.3V±5% at the SFP connector pin. Maximum supply current is 300mA. Recommended host board power supply filtering is shown below. Inductors with DC resistance of less than 1Ω should be used in order to maintain the required voltage at the SFP input pin with 3.3V supply voltage. When the recommended supply-filtering network is used, hot plugging of the SFP transceiver module will result in an inrush current of no more than 30mA greater than the steady state value. VccR and VccT may be internally connected within the SFP transceiver module.
8. TD±: these are the differential transmitter inputs. They are AC coupled, differential lines with 100Ω differential termination inside the module. The AC coupling is done inside the module and is thus not required on the host board. The inputs will accept differential swings of 400mV to 2000mV (250mV to 1200mV single-ended), though it is recommended that values between 500mV and 1200mV differential (250mV to 600mV single-ended) be used for best EMI performance.
9. Function not available.

### Electrical Pin-out Details

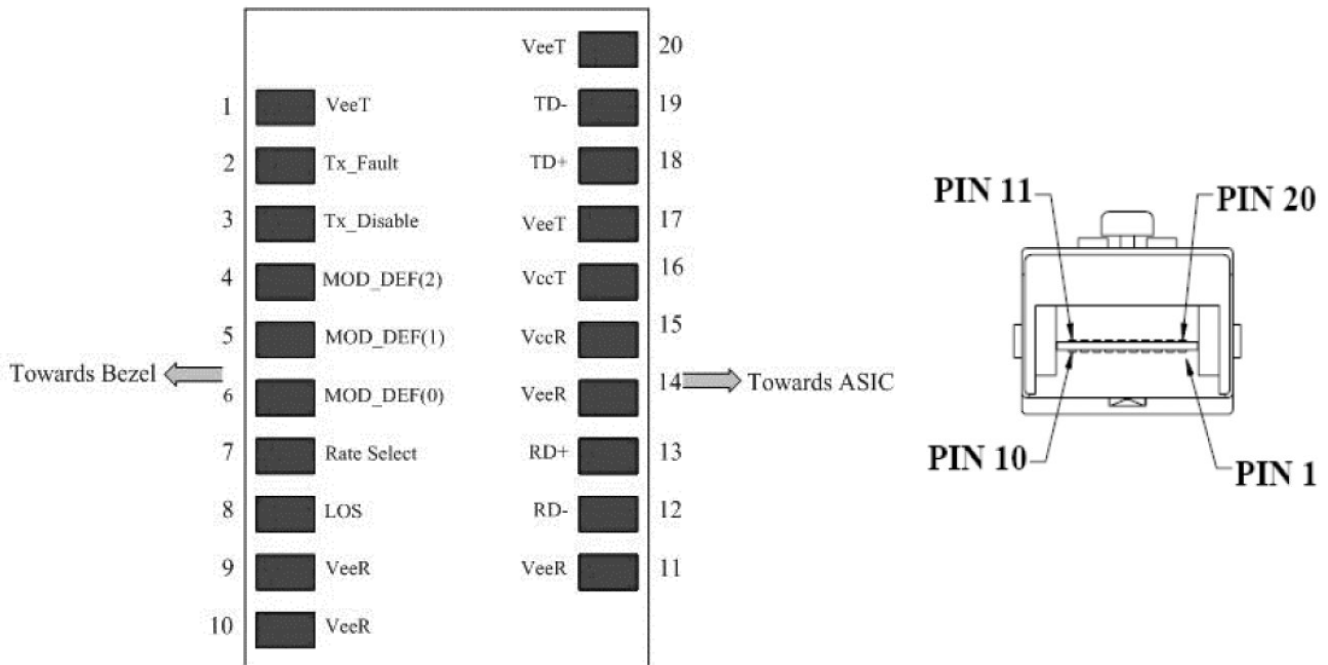

## Functional Description of the Transceiver

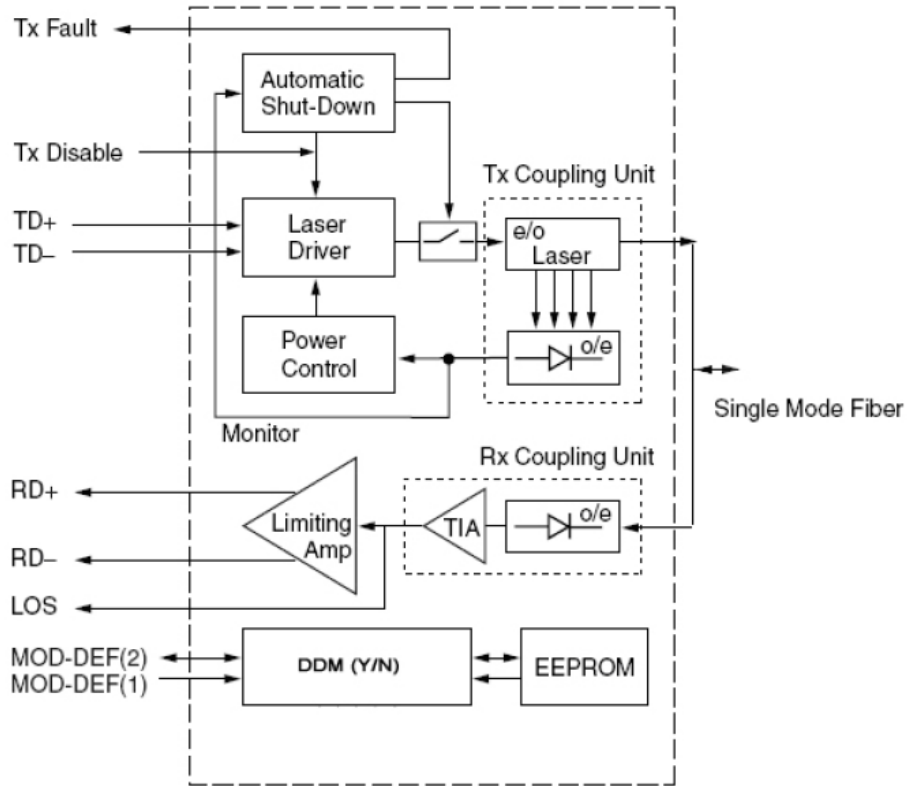

## Recommended Circuit Schematic

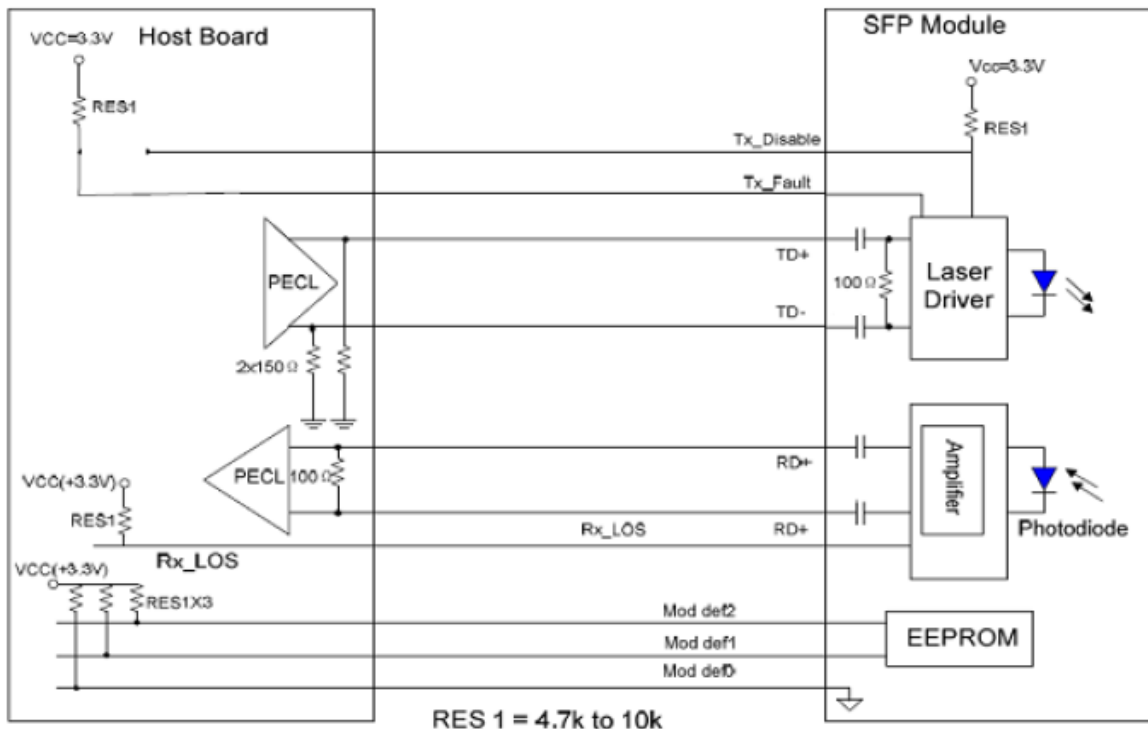

## EEPROM

The serial interface uses the 2-wire serial CMOS EEPROM protocol defined for the ATMEL AT24C02/04 family of components. When the serial protocol is activated, the host generates the serial clock signal (SCL). The positive edge clocks data into those segments of the EEPROM that are not write protected within the SFP transceiver. The negative edge clocks data from the SFP transceiver. The serial data signal (SDA) is bidirectional for serial data transfer. The host uses SDA in conjunction with SCL to mark the start and end of serial protocol activation. The memories are organized as a series of 8-bit data words that can be addressed individually or sequentially.

The module provides diagnostic information about the present operating conditions. The transceiver generates this diagnostic data by digitization of internal analog signals. Calibration and alarm/warning threshold data is written during device manufacture. Received power monitoring, transmitted power monitoring, bias current monitoring, supply voltage monitoring, and temperature monitoring all are implemented. The diagnostic data are raw A/D values and must be converted to real world units using calibration constants stored in EEPROM locations 56 – 95 at wire serial bus address A2h. The digital diagnostic memory map specific data field define as following. For detailed EEPROM information, please refer to the related document of SFF 8472 Rev 9.3.

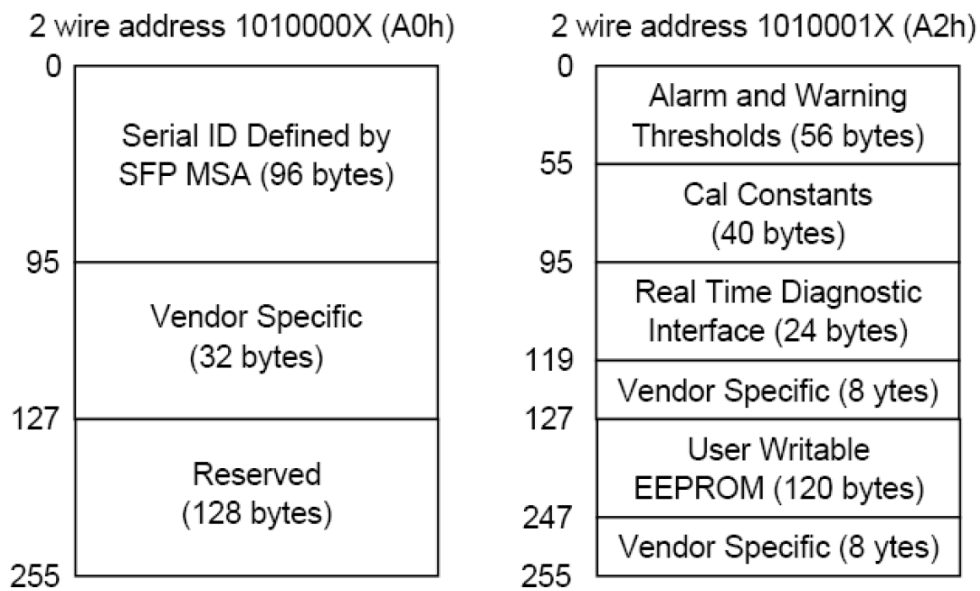

**Mechanical Specifications**

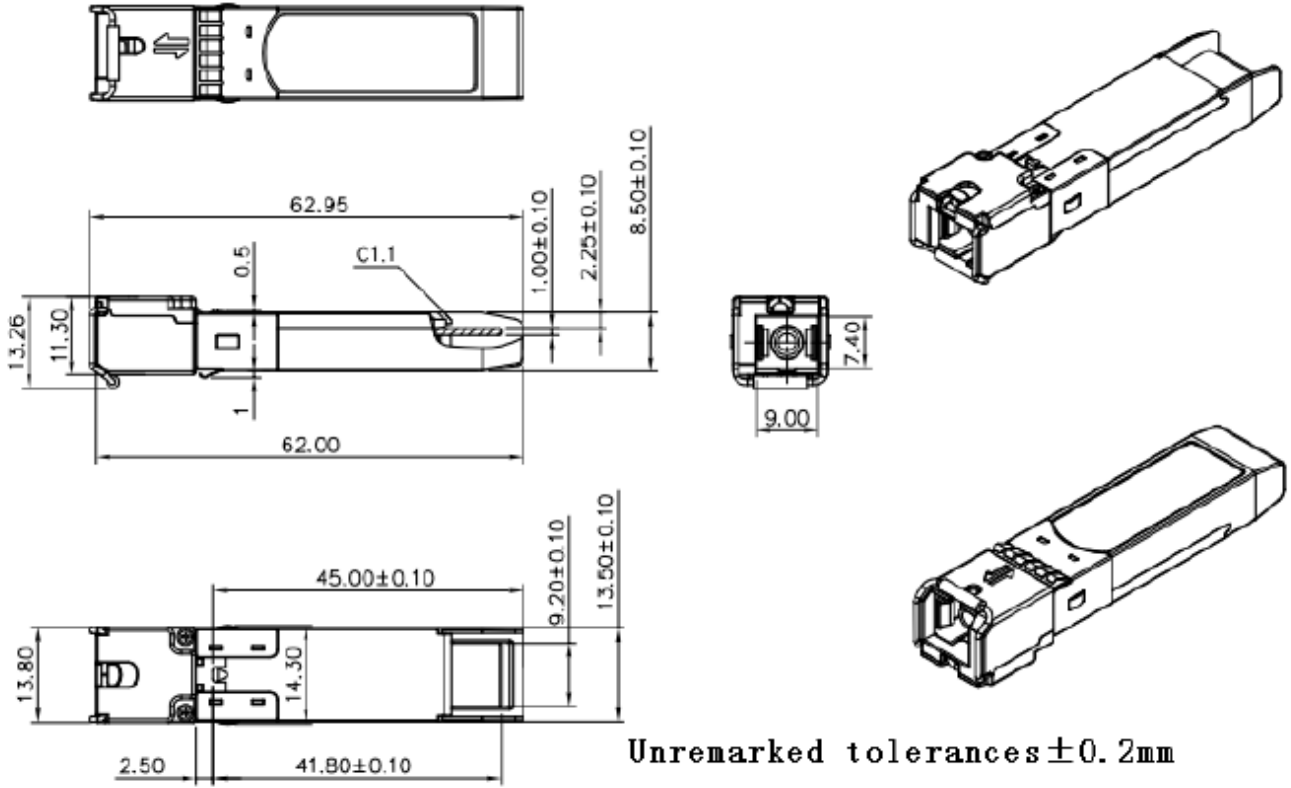

Unremarked tolerances ±0.2mm

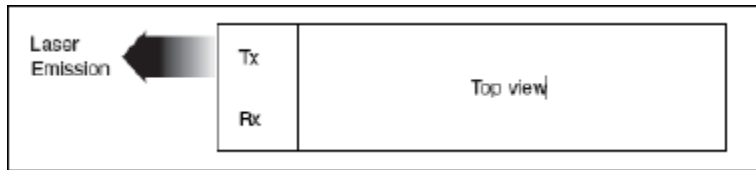

## About ProLabs

Our extensive experience comes as standard. For over 20 years ProLabs has delivered optical connectivity solutions that give our customers freedom and choice through our ability to provide seamless interoperability. At the heart of our company is the ability to provide state-of-the-art optical transport and connectivity solutions that are compatible with more than 100 optical switching and transport platforms.

## A Complete Portfolio of Network Solutions

ProLabs is focused on innovations in optical transport and connectivity. The combination of our knowledge of optics and networking equipment enables ProLabs to be your single source for optical transport and connectivity solutions from 100Mb to 1.6T while providing innovative solutions that increase network efficiency. We provide the optical connectivity expertise that is compatible with and enhances your switching and transport equipment.

## The Trusted Partner

Customer service is our number one value. ProLabs has invested in people, labs and manufacturing capacity to ensure compatible products, and immediate answers to your questions. With Engineering and Manufacturing offices in the U.K. and U.S. augmented by field offices throughout the U.S., U.K. and Asia, ProLabs is able to be our customers best advocate 24 hours a day.



## Contact Information

ProLabs US

Email: [sales@prolabs.com](mailto:sales@prolabs.com)

Telephone: 952-852-0252

ProLabs UK

Email: [salessupport@prolabs.com](mailto:salessupport@prolabs.com)

Telephone: +44 1285 719 600