

JF833A-C

HP® JF833A Compatible TAA 100Base-FX SFP Transceiver (MMF, 1310nm, 2km, LC, DOM)

Features:

- INF-8074 and SFF-8472 Compliance
- Duplex LC Connector
- Multi-mode Fiber
- Commercial Temperature 0 to 70 Celsius
- Hot Pluggable
- Metal with Lower EMI
- Excellent ESD Protection
- RoHS Compliant and Lead Free



Applications:

- 100Base Ethernet
- Access and Enterprise

Product Description

This HP® JF833A compatible SFP transceiver provides 100Base-FX throughput up to 2km over multi-mode fiber (MMF) using a wavelength of 1310nm via an LC connector. It can operate at temperatures between 0 and 70C. Our transceiver is built to meet or exceed OEM specifications and is guaranteed to be 100% compatible with HP®. It has been programmed, uniquely serialized, and tested for data-traffic and application to ensure that it will initialize and perform identically. All of our transceivers comply with Multi-Source Agreement (MSA) standards to provide seamless network integration. Additional product features include Digital Optical Monitoring (DOM) support which allows access to real-time operating parameters. This transceiver is Trade Agreements Act (TAA) compliant. We stand behind the quality of our products and proudly offer a limited lifetime warranty.

ProLabs' transceivers are RoHS compliant and lead-free.

TAA refers to the Trade Agreements Act (19 U.S.C. & 2501-2581), which is intended to foster fair and open international trade. TAA requires that the U.S. Government may acquire only "U.S.-made or designated country end products."



Absolute Maximum Ratings

Parameter	Symbol	Min.	Typ.	Max.	Unit
Maximum Supply Voltage	Vcc	-0.5		3.6	V
Storage Temperature	Tstg	-40		85	°C
Operating Case Temperature	Tc	0		70	°C
Operating Humidity	RH			95	%
Receiver Power	R _{MAX}			-12	dBm
Data Rate			100/155		Mbps
50µm Core Diameter MMF	L		2		km

Electrical Characteristics

Parameter	Symbol	Min.	Typ.	Max.	Unit	Notes
Power Supply Voltage	Vcc	3.15	3.30	3.45	V	
Power Supply Current	Icc			300	mA	
Transmitter						
LVPECL Differential Inputs	VIN	400		2000	mVp-p	1
Input Differential Impedance	ZIN	85	100	120	Ω	2
Tx_Disable	Disable		2	Vcc	V	
	Enable		0	0.8	V	
Tx_Fault	Fault		2	Vcc+0.3	V	
	Normal		0	0.5	V	
Receiver						
LVPECL Differential Outputs	VOUT	400		2000	mVp-p	1
Output Differential Impedance	ZIN	85	100	120	Ω	
Tx_Disable Assert Time	T _{off}			10	us	
Rx_LOS	LOS		2	Vcc+0.3	V	
	Normal		0	0.8	V	
MOD_DEF (0.2)	VOH	2.5			V	3
	VOL	0		0.8	V	3

Notes:

1. AC Coupled.
2. RIN > 100kΩ @ DC.
3. With Serial ID.

Optical Characteristics

Parameter	Symbol	Min.	Typ.	Max.	Unit	Notes
Transmitter						
Average Output Power	POUT	-19		-14	dBm	1
Optical Extinction Ratio	ER	10			dB	2
Optical Wavelength	$T\lambda$	1260	1310	1360	nm	
Spectral Width (RMS)	$\Delta\lambda$			4	nm	
Total Jitter	TJ			1	ns	2
Tx_Disable Asserted Time	T_off			10	us	
POUT @ Tx_Disable Asserted	POUT			-45	dBm	
Rise/Fall Time (20-80%)	T_r/T_f			2	ns	
Output Optical Eye		IUT-T G.957 Compliant				
Receiver						
Receiver Sensitivity	P_{min}			-31	dBm	3
Receiver Overload	P_{max}	-12			dBm	
Optical Center Wavelength	λ_C	1260		1600	nm	
Return Loss		14			dB	

Notes:

1. Output power is measured by coupling into a 50/125mm multi-mode fiber.
2. Filtered. Measured with a PRBS $2^{23}-1$ test pattern @155Mbps.
3. Minimum average optical power is measured at BER less than $1E^{-12}$ with $2^{23}-1$ PRBS and ER=9dB.

Pin Descriptions

Pin	Symbol	Name/Description	Note
1	VeeT	Transmitter Ground. Common with Receiver Ground.	1
2	Tx_Fault	Transmitter Fault. LVTTTL-O.	2
3	Tx_Disable	Transmitter Disable. Laser output disabled on "high" or "open." LVTTTL-I.	3
4	SDA	2-Wire Serial Interface Data (Same as MOD-DEF2 in INF-8074i). LVTTTL-I/O.	
5	SCL	2-Wire Serial Interface Clock (Same as MOD-DEF2 in INF-8074i). LVTTTL-I.	
6	MOD_ABS	Module Absent. Connect to VeeT or VeeR in the module.	4
7	RS0	Rate Select 0. Not Used.	5
8	LOS	Loss of Signal indication. Logic 0 indicates normal operation. LVTTTL-O.	2
9	RS1	Rate Select 1. Not Used.	5
10	VeeR	Receiver Ground. Common with Transmitter Ground.	1
11	VeeR	Receiver Ground. Common with Transmitter Ground.	1
12	RD-	Receiver Inverted Data Out. AC Coupled. CML-O.	
13	RD+	Receiver Non-Inverted Data Out. AC Coupled. CML-O.	
14	VeeR	Receiver Ground. Common with Transmitter Ground.	1
15	VccR	Receiver Power Supply.	
16	VccT	Transmitter Power Supply.	
17	VeeT	Transmitter Ground. Common with Receiver Ground.	1
18	TD+	Transmitter Non-Inverted Data In. AC Coupled. CML-I.	
19	TD-	Transmitter Inverted Data In. AC Coupled. CML-O.	
20	VeeT	Transmitter Ground. Common with Receiver Ground.	1

Notes:

1. The module signal ground contacts, VeeR and VeeT, should be isolated from the module case.
2. This contact is an open collector/drain output and should be pulled up to the Host_Vcc with a resistor in the range 4.7kΩ-10kΩ. Pull-ups can be connected to one or several power supplies; however, the host board design shall ensure that no module contact has a voltage exceeding the module $V_{ccT}/R+0.5V$.
3. Tx_Disable is an input contact with a 4.7kΩ-10kΩ pull-up resistor to the VccT inside the module.
4. MOD_ABS is connected to the VeeT or VeeR in the SFP+ module. The host may pull the contact up to the Host_Vcc with a resistor in the range from 4.7kΩ-10kΩ. MOD_ABS is asserted "high" when the SFP+ module is physically absent from a host slot.
5. Internally pulled down per SFF-8431.



Pin-Out of Connector Block on the Host Board

Recommended Circuit Schematic

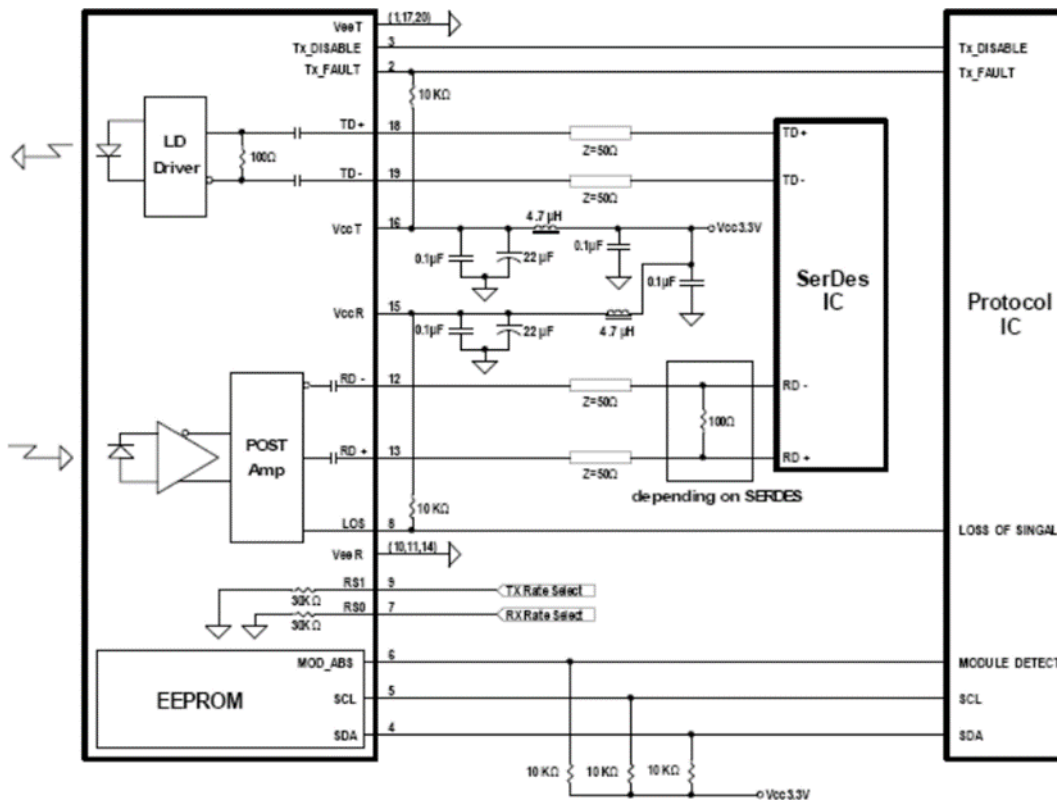

Mechanical Specifications

Small Form Factor Pluggable (SFP) transceivers are compatible with the dimensions defined by the SFP Multi- Sourcing Agreement (MSA).

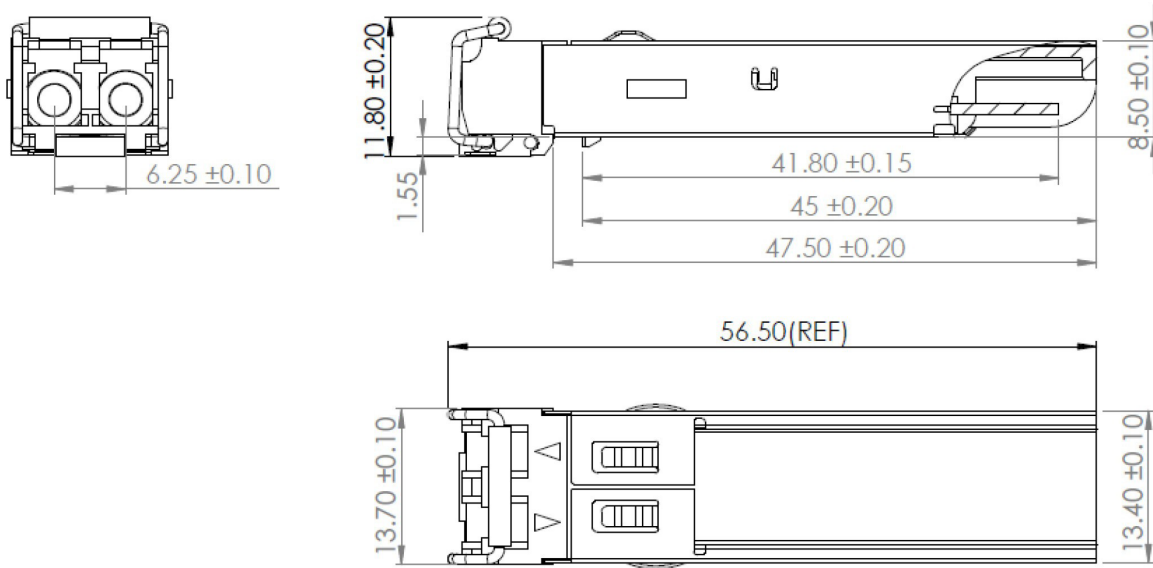

EEPROM Information

EEPROM memory map-specific data field description is as below:

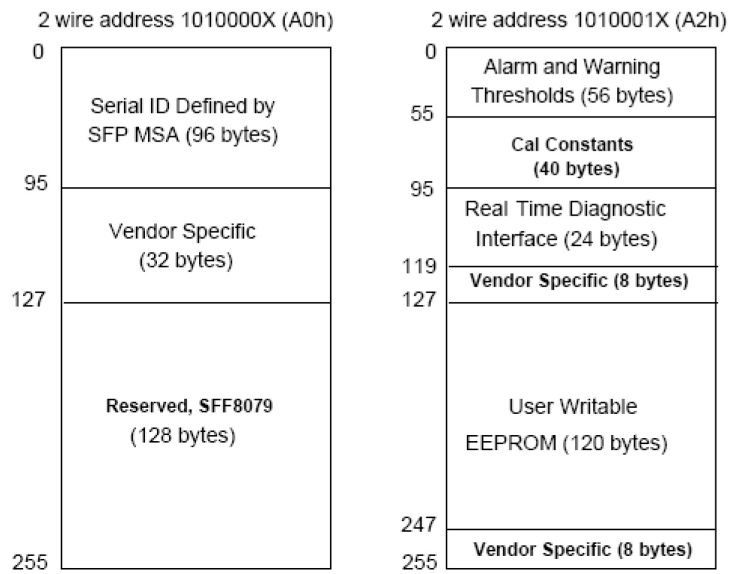

About ProLabs

Our extensive experience comes as standard. For over 20 years ProLabs has delivered optical connectivity solutions that give our customers freedom and choice through our ability to provide seamless interoperability. At the heart of our company is the ability to provide state-of-the-art optical transport and connectivity solutions that are compatible with more than 100 optical switching and transport platforms.

A Complete Portfolio of Network Solutions

ProLabs is focused on innovations in optical transport and connectivity. The combination of our knowledge of optics and networking equipment enables ProLabs to be your single source for optical transport and connectivity solutions from 100Mb to 1.6T while providing innovative solutions that increase network efficiency. We provide the optical connectivity expertise that is compatible with and enhances your switching and transport equipment.

The Trusted Partner

Customer service is our number one value. ProLabs has invested in people, labs and manufacturing capacity to ensure compatible products, and immediate answers to your questions. With Engineering and Manufacturing offices in the U.K. and U.S. augmented by field offices throughout the U.S., U.K. and Asia, ProLabs is able to be our customers best advocate 24 hours a day.



Contact Information

ProLabs US

Email: sales@prolabs.com

Telephone: 952-852-0252

ProLabs UK

Email: salessupport@prolabs.com

Telephone: +44 1285 719 600