

SFP-25GB-DW20-10-I-IN-AO

Intel® Compatible TAA 25GBase-DWDM SFP28 Transceiver C-Band 100GHz (SMF, 1561.42nm, 10km, LC, DOM, -40 to 85C)

Features

- SFF-8432 and SFF-8472 Compliance
- Duplex LC Connector
- Industrial Temperature -40 to 85 Celsius
- Single-mode Fiber
- Hot Pluggable
- Excellent ESD Protection
- Metal with Lower EMI
- RoHS Compliant and Lead Free



Applications

- 25x Gigabit Ethernet over DWDM
- Access and Enterprise

Product Description

This Intel® compatible SFP28 transceiver provides 25GBase-DWDM throughput up to 10km over single-mode fiber (SMF) using a wavelength of 1561.42nm via an LC connector. It is capable of withstanding rugged environments and can operate at temperatures between -40 and 85C. Our transceiver is built to meet or exceed OEM specifications and is guaranteed to be 100% compatible with Intel®. It has been programmed, uniquely serialized, and tested for data-traffic and application to ensure that it will initialize and perform identically. All of our transceivers comply with Multi-Source Agreement (MSA) standards to provide seamless network integration. Additional product features include Digital Optical Monitoring (DOM) support which allows access to real-time operating parameters. This transceiver is Trade Agreements Act (TAA) compliant. We stand behind the quality of our products and proudly offer a limited lifetime warranty.

AddOn's transceivers are RoHS compliant and lead-free.

TAA refers to the Trade Agreements Act (19 U.S.C. & 2501-2581), which is intended to foster fair and open international trade. TAA requires that the U.S. Government may acquire only "U.S.-made or designated country end products."



SFP Channel Number and Wavelength

Channel	Frequency (THz)	Center Wavelength (nm)	Channel	Frequency (THz)	Center Wavelength (nm)
15	191.5	1565.50	39	193.9	1546.12
16	191.6	1564.68	40	194.0	1545.32
17	191.7	1563.86	41	194.1	1544.53
18	191.8	1563.05	42	194.2	1543.73
19	191.9	1562.23	43	194.3	1542.94
20	192.0	1561.42	44	194.4	1542.14
21	192.1	1560.61	45	194.5	1541.35
22	192.2	1559.79	46	194.6	1540.56
23	192.3	1558.98	47	194.7	1539.77
24	192.4	1558.17	48	194.8	1538.98
25	192.5	1557.36	49	194.9	1538.19
26	192.6	1556.55	50	195.0	1537.40
27	192.7	1555.75	51	195.1	1536.61
28	192.8	1554.94	52	195.2	1535.82
29	192.6	1554.13	53	195.3	1535.04
30	193.0	1553.33	54	195.4	1534.25
31	193.1	1552.52	55	195.5	1533.47
32	193.2	1551.72	56	195.6	1532.68
33	193.3	1550.92	57	195.7	1531.90
34	193.4	1550.12	58	195.8	1531.12
35	193.5	1549.32	59	195.9	1530.33
36	193.6	1548.51	60	196.0	1529.55
37	193.7	1547.72	61	196.1	1528.77
38	193.8	1546.92			

Absolute Maximum Ratings

Parameter	Symbol	Min.	Typ.	Max.	Unit	Notes
Storage Temperature	Tstg	-40		85	°C	
Operating Case Temperature	Tc	-40		85	°C	
Supply Voltage	Vcc	-0.5		3.6	V	
Supply Current	Icc			606	mA	
Operating Relative Humidity	RH	5		85	%	

Electrical Characteristics

Parameter	Symbol	Min.	Typ.	Max.	Unit	Notes
Supply Voltage	Vcc	3.15	3.3	3.45	V	
Transmitter						
CML Differential Inputs	VIN	40		1000	mVp-p	1
Input Differential Impedance	ZIN		100		Ω	2
Tx_Disable	Disable	2		Vcc+0.3	V	
	Enable	0		0.8	V	
Tx_Fault	Fault	2.4		Vcc+0.3	V	
	Normal	0		0.4	V	
Receiver						
CML Differential Outputs	VOUT	300		850	mV	3
Output Differential Impedance	ZOUT	85	100	115	Ω	
Rx_LOS	LOS	2.4		Vcc+0.3	V	
	Normal	0		0.4	V	

Notes:

1. AC coupled input. CML logic. Internally AC coupled.
2. RIN>100kΩ @ DC.
3. AC coupled output. CML logic. Internally AC coupled.

Optical Characteristics

Parameter	Symbol	Min.	Typ.	Max.	Unit	Notes
Transmitter						
Center Wavelength Spacing			100		GHz	
			0.8		nm	
Side-Mode Suppression Ratio	SMSR	30			dB	
Average Output Power @25.78Gbps	POUT	-1		4	dBm	1
Extinction Ratio	ER	6			dB	
Receiver						
Receiver Sensitivity @25.78Gbps	Pmin			-14	dBm	2
Receiver Overload	Pmax	2			dBm	3
LOS De-Assert	LOSD			-17	dBm	
LOS Assert	LOSA	-30			dBm	
LOS Hysteresis		0.5			dB	
Optical Signal to Noise Ratio Tolerance	OSNR	33			dB	

Notes:

1. Output is coupled into a 9/125 μ m single-mode fiber.
2. Minimum average optical power measured at the BER less than $5E^{-5}$. The measure pattern is PRBS $2^{31}-1$.
3. It's suggested to use a >3dB attenuator between the transmitter and receiver if testing Tx to Rx directly.

Pin Descriptions

Pin	Symbol	Name/Description	Plug Seq.	Notes
1	VeeT	Transmitter Ground.	1	5
2	Tx_Fault	Transmitter Fault Indication.	3	1
3	Tx_Disable	Transmitter Disable. Module disables on “high” or “open.”	3	2
4	SDA	Module Definition 2. Data Line for Serial ID.	3	3
5	SCL	Module Definition 1. Clock Line for Serial ID.	3	3
6	MOD_ABS	Module Definition 0.	3	3
7	RS0	Rx Rate Select (LVTTTL).	3	9
8	Rx_LOS	Loss of Signal.	3	4
9	RS1	Tx Rate Select (LVTTTL).	1	10
10	VeeR	Receiver Ground.	1	5
11	VeeR	Receiver Ground.	1	5
12	RD-	Inverse Received Data Out.	3	6
13	RD+	Received Data Out.	3	7
14	VeeR	Receiver Ground.	1	5
15	VccR	3.3±5% Receiver Power.	2	7
16	VccT	3.3±5% Transmitter Power.	2	7
17	VeeT	Transmitter Ground.	1	5
18	TD+	Transmitter Data In.	3	8
19	TD-	Inverse Transmitter Data In.	3	8
20	VeeT	Transmitter Ground.	1	5

Notes:

1. Tx_Fault is an open collector/drain output that should be pulled up with a 4.7kΩ to 10kΩ resistor on the host board. Pull-up voltage between 2.4V and $V_{ccT}/R+0.3V$. When “high,” output indicates a laser fault of some kind. “Low” indicates normal operation. In the “low” state, the output will be pulled to <0.4V.
2. Tx_Disable is an input that is used to shut down the transmitter optical output. It is pulled up within the module with a 4.7kΩ to 10kΩ resistor. Its states are:
 - Low (-0.3V – 0.8V): Transmitter On.
 - Between (>0.8V and <2.0V): Undefined.
 - High (2.0V – $V_{ccT}/R+0.3V$): Transmitter Disabled.
 - Open: Transmitter Disabled.
3. Module Absent. Connected to the VeeT or VeeR in the module.
4. Rx_LOS (Loss of Signal) is an open collector/drain output that should be pulled up with a 4.7kΩ to 10kΩ resistor. Pull-up voltage between 2.4V and $V_{ccT}/R+0.3V$. When “high,” this output indicates the received optical power is below the worst-case receiver sensitivity (as defined by the standard in use). “Low” indicates normal operation. In the “low” state, the output will be pulled to <0.4V.

5. VeeR and VeeT may be internally connected within the SFP28 module.
6. RD-/+. These are the differential receiver outputs. They are AC-coupled, 100Ω differential lines which should be terminated with 100Ω (differential) at the user SERDES. The AC coupling is done inside the module and is thus not required on the host board. The voltage swing on these lines will be between 225mV and 525mV single-ended when properly terminated.
7. VccR and VccT are the receiver and transmitter power supplies. They are defined as 3.3V±5% at the SFP + connector pin. Maximum supply current is 606mA. Indicators with DC resistance of less than 1Ω should be used in order to maintain the required voltage at the SFP28 input pin with 3.3V supply voltage. When the recommended supply filtering network is used, hot-plugging of the SFP28 transceiver module will result in an in-rush current of no more than 30mA greater than the steady state value. VccR and VccT may be internally connected within the SFP28 transceiver module.
8. TD-/+. These are the differential transmitter inputs. They are AC-coupled, differential lines with 100Ω differential terminations inside the module. The AC coupling is done inside the module and is thus not required on the host board. The inputs will accept swings of 20mV to 50mV (single-ended), though it is recommended that values between 90mV to 900mV (single-ended) be used for best EMI performance.
9. This pin has an internal 47k pull-down to ground. RS0=1 sets Rx CDR enable, while RS0=0 sets Rx CDR bypass.
10. This pin has an internal 47k pull-down to ground. RS1=1 sets Tx CDR enable, while RS1=0 sets Tx CDR bypass.

Electrical Pad Layout

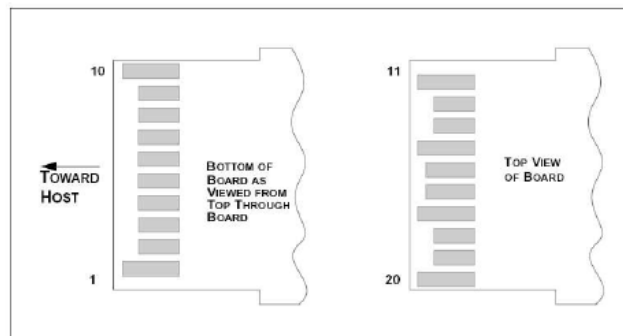
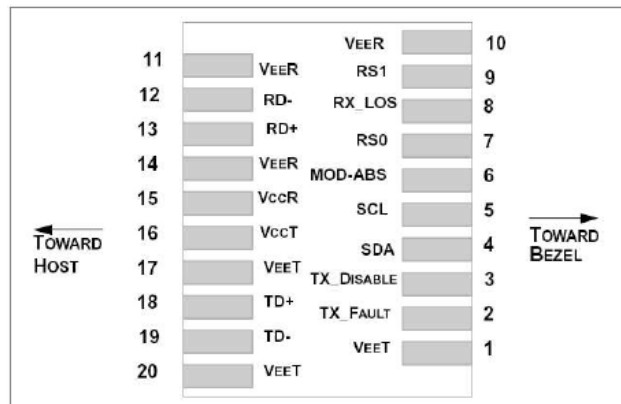

Mechanical Specifications

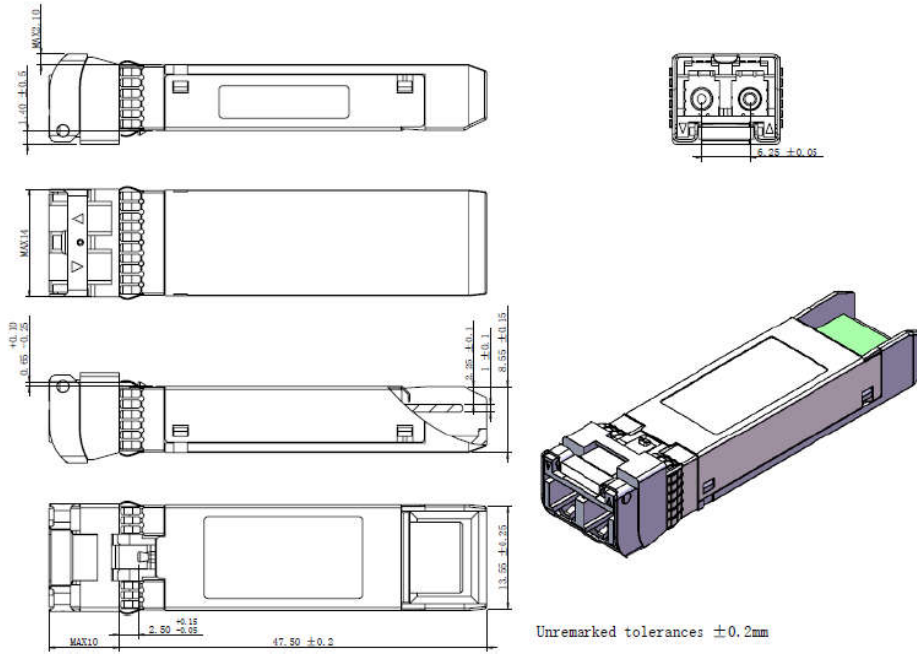

All dimensions are $\pm 0.2\text{mm}$ unless otherwise specified.

Unit: mm

About AddOn Networks

In 1999, AddOn Networks entered the market with a single product. Our founders fulfilled a severe shortage for compatible, cost-effective optical transceivers that compete at the same performance levels as leading OEM manufacturers. Adhering to the idea of redefining service and product quality not previously had in the fiber optic networking industry, AddOn invested resources in solution design, production, fulfillment, and global support.

Combining one of the most extensive and stringent testing processes in the industry, an exceptional free tech support center, and a consistent roll-out of innovative technologies, AddOn has continually set industry standards of quality and reliability throughout its history.

Reliability is the cornerstone of any optical fiber network and is ingrained in AddOn's DNA. It has played a key role in nurturing the long-term relationships developed over the years with customers. AddOn remains committed to exceeding industry standards with certifications ranging from NEBS Level 3 to ISO 9001:2015 with every new development while maintaining the signature reliability of its products.



U.S. Headquarters

Email: sales@addonnetworks.com

Telephone: +1 877.292.1701

Fax: 949.266.9273

Europe Headquarters

Email: salesemea@addonnetworks.com

Telephone: +44 1285 842070