

SFP28-25GB-CLR-J-OPC

Juniper Networks® Compatible TAA 25GBase-CLR SFP28 Transceiver (SMF, 1310nm, 2km, LC, DOM, No FEC)

Features

- Up to 25.78125Gbd Bi-Directional Data Links
- Built-In Dual CDR with Bypass Control
- Electrical Interface Specifications Per SFF-8431
- SFP28 MSA Package with Duplex Connector
- 1.5W Maximum Power Consumption with Established Link
- Class 1 Laser Safety Certified
- Uncooled 1310 DFB Laser
- Up to 2km on 9/125um SMF with No FEC
- Power Supply Lines: 3.3V
- Operating Temperature: 0 to 70 Celsius
- RoHS Compliant and Lead-Free



Applications:

- 25GBase Ethernet

Product Description

This Juniper Networks® compatible SFP28 transceiver provides 25GBase-CLR throughput up to 2km over single-mode fiber (SMF) using a wavelength of 1310nm via an LC connector. It can operate at temperatures between 0 and 70C. Our transceiver is built to meet or exceed OEM specifications and is guaranteed to be 100% compatible with Juniper Networks®. It has been programmed, uniquely serialized, and tested for data-traffic and application to ensure that it will initialize and perform identically. All of our transceivers comply with Multi-Source Agreement (MSA) standards to provide seamless network integration. Additional product features include Digital Optical Monitoring (DOM) support which allows access to real-time operating parameters. This transceiver is Trade Agreements Act (TAA) compliant. We stand behind the quality of our products and proudly offer a limited lifetime warranty.

OptioConnect's transceivers are RoHS compliant and lead-free.

Absolute Maximum Ratings

Parameter	Symbol	Min.	Typ.	Max.	Unit	Notes
Maximum Supply Voltage	V _{CC}	-0.5		4	V	1
Storage Temperature	T _{stg}	-40		85	°C	
Operating Case Temperature	T _c	0	25	70	°C	
Relative Humidity	RH	5		95	%	
Signaling Rate			25.78125		GBd	
Signaling Rate Variation		-100		100	ppm	

Electrical Characteristics

Parameter	Symbol	Min.	Typ.	Max.	Unit	Notes
Module Supply Voltage	V _{CC}	3.14	3.3	3.47	V	
Module Supply Current	I _{CC}			478	mA	
Power Dissipation	P _{DISS}			1500	W	
Transmitter						
Input Differential Impedance	Z _{IN}		100		Ω	
Differential Data Input Swing	V _{IN,pp}	180		700	mVp-p	
Tx_Fault	Transmitter Fault	VOH	2	Host_Vcc	V	
	Normal Operation	VOL	0	0.8	V	
Tx_Disable	Transmitter Disable	VIH	2	Host_Vcc	V	
	Transmitter Enable	VIL	0	0.8	V	
Receiver						
Output Differential Impedance	Z _{OUT}		100		Ω	
AC Common-Mode Output Voltage	V _{OUT,rms}			17.5	mV	
Differential Output Voltage	V _{OUT,pp}	300		900	mVp-p	1
Eye Width		0.57			UI	
Differential Eye Hight		228			mV	
Data Output Rise/Fall Time	T _r /T _f	12			ps	2
Rx_LOS	Loss of Signal (LOS)	VOH	2.0	Host_Vcc	V	3
	Normal Operation	VOL	0	0.8	V	3

Notes:

1. Internally AC coupled but requires an external 100Ω differential load termination.
2. 20-80%.
3. LOS is an open collector output and should be pulled up with 4.7kΩ on the host board.

Optical Characteristics

Parameter	Symbol	Min.	Typ.	Max.	Unit	Notes
Transmitter						
Launch Optical Power	Po	-5		2	dBm	1
Extinction Ratio	ER	3.5			dB	
Optical Modulation Amplitude	OMA	-4		2.2	dB	
Center Wavelength Range	λ_C	1295	1310	1325	nm	
Side-Mode Suppression Ratio	SMSR	30			dB	
Spectral Width	$\Delta\lambda$			1	nm	2
Launch Power in OMA Minus TDP		-5			dBm	
Transmitter and Dispersion Penalty	TDP			2.7	dB	
Optical Return Loss Tolerance	ORLT			20	dB	
Transmitter Reflectance				-26	dB	
POUT @Tx_Disable Asserted	Poff			-20	dBm	
Receiver						
Center Wavelength	λ_C	1260	1310	1370	nm	
Receiver Sensitivity	RxSens			-8	dBm	3
Damage Threshold		3			dBm	
Receiver Overload (Pavg)	POL	2			dBm	
Optical Return Loss	ORL	26			dB	
LOS De-Assert	LOSD			-16	dBm	
LOS Assert	LOSA	-30			dBm	
LOS Hysteresis		0.5			dB	
Receiver Reflectance				-26	dBm	

Notes:

1. Class 1 Laser Safety per FDA/CDRH and EN (IEC) 60825 regulations.
2. 20dB spectral width.
3. Measured with PRBS31 at $1E^{-12}$ BER.

Pin Descriptions

Pin	Symbol	Name/Description	Notes
1	VeeT	Transmitter Ground.	1
2	Tx_Fault	Transmitter Fault. LVTTTL-O. "High" indicates a fault condition.	2
3	Tx_Disable	Transmitter Disable. LVTTTL-I. "High" or "open" disables the transmitter.	3
4	SDA	2-Wire Serial Interface Data. LVCMOS-I/O. MOD-DEF2.	4
5	SCL	2-Wire Serial Interface Clock. LVCMOS-I/O. MOD-DEF1.	4
6	MOD_ABS	Module Absent (Output). Connected to the VeeT or VeeR in the module.	5
7	RS0	Hardware Tx Rate Select Pin.	6
8	Rx_LOS	Receiver Loss of Signal. LVTTTL-O.	2
9	RS1	Hardware Rx Rate Select Pin.	6
10	VeeR	Receiver Ground.	1
11	VeeR	Receiver Ground.	1
12	RD-	Inverse Received Data Out. CML-O.	
13	RD+	Received Data Out. CML-O.	
14	VeeR	Receiver Ground.	
15	VccR	+3.3V Receiver Power.	
16	VccT	+3.3V Transmitter Power.	
17	VeeT	Transmitter Ground.	1
18	TD+	Transmitter Data In. CML-I.	
19	TD-	Inverse Transmitter Data In. CML-I.	
20	VeeT	Transmitter Ground.	1

Notes:

1. The module signal grounds are isolated from the module case.
2. This is an open collector/drain output that, on the host board, requires a 4.7k Ω to 10k Ω pull-up resistor to the Host_Vcc.
3. This input is internally biased "high" with a 4.7k Ω to 10k Ω pull-up resistor to the VccT.
4. 2-Wire Serial Interface Clock and Data lines require an external pull-up resistor dependent on the capacitance load.
5. This is a ground return that, on the host board, requires a 4.7k Ω to 10k Ω pull-up resistor to the Host_Vcc.
6. Rate Select can also be set through the 2-wire bus in accordance with SFF-8472 v. 12.1. Rx Rate Select is set at Bit 3, Byte 110, and Address A2h, and Tx Rate Select is set at Bit 3, Byte 118, and Address A2h.
Note: Writing a "1" selects maximum bandwidth operation. Rate Select is the logic OR of the input state of the Rate Select Pin and 2-wire bus.

Electrical Pin-Out Details

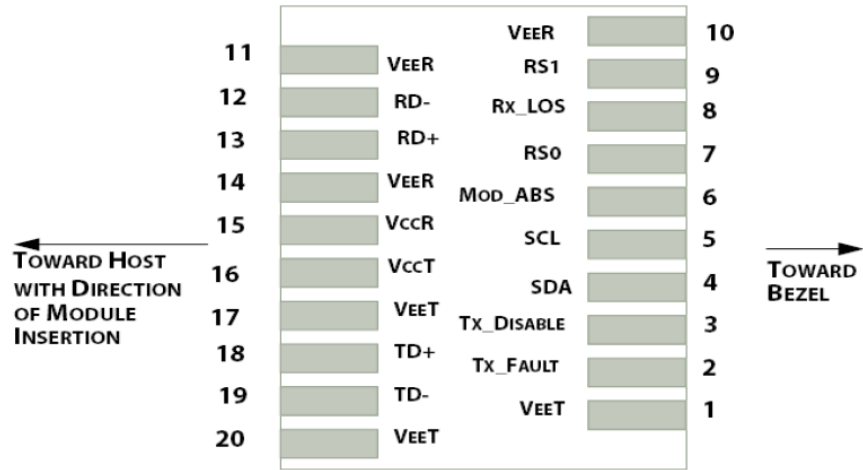

Host Board Power Supply Filter Network

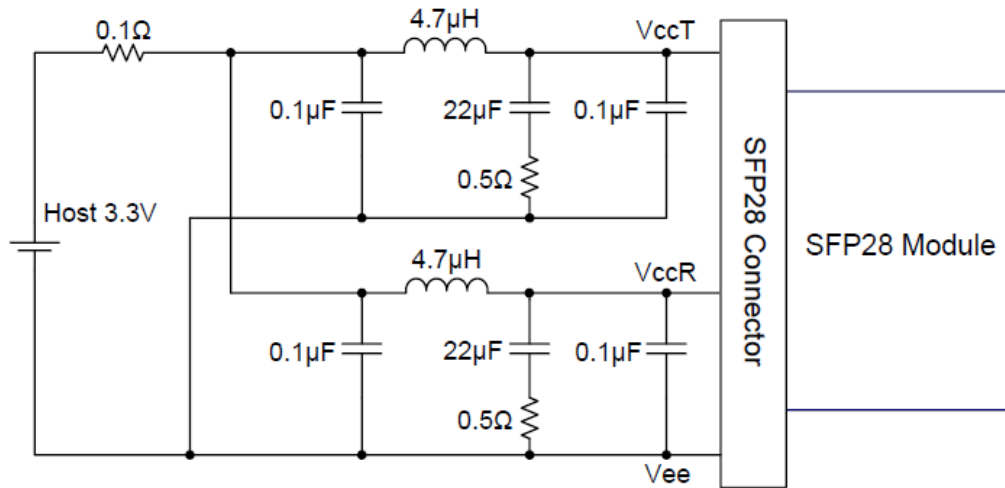

Block Diagram

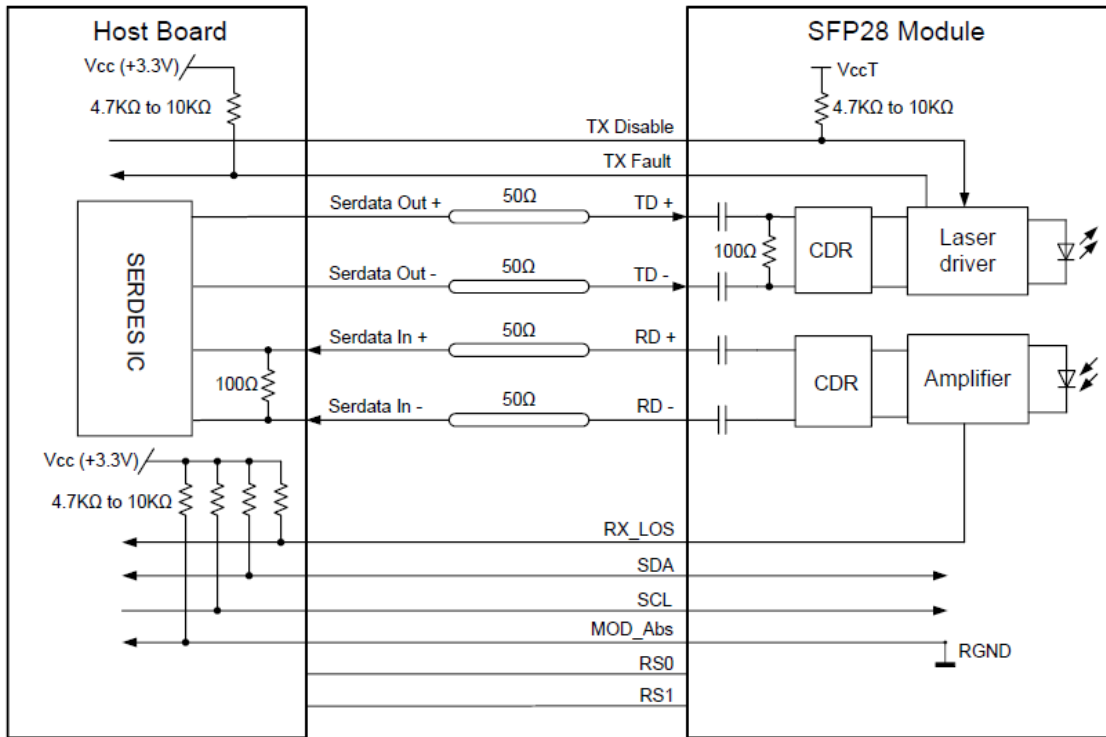

Mechanical Specifications

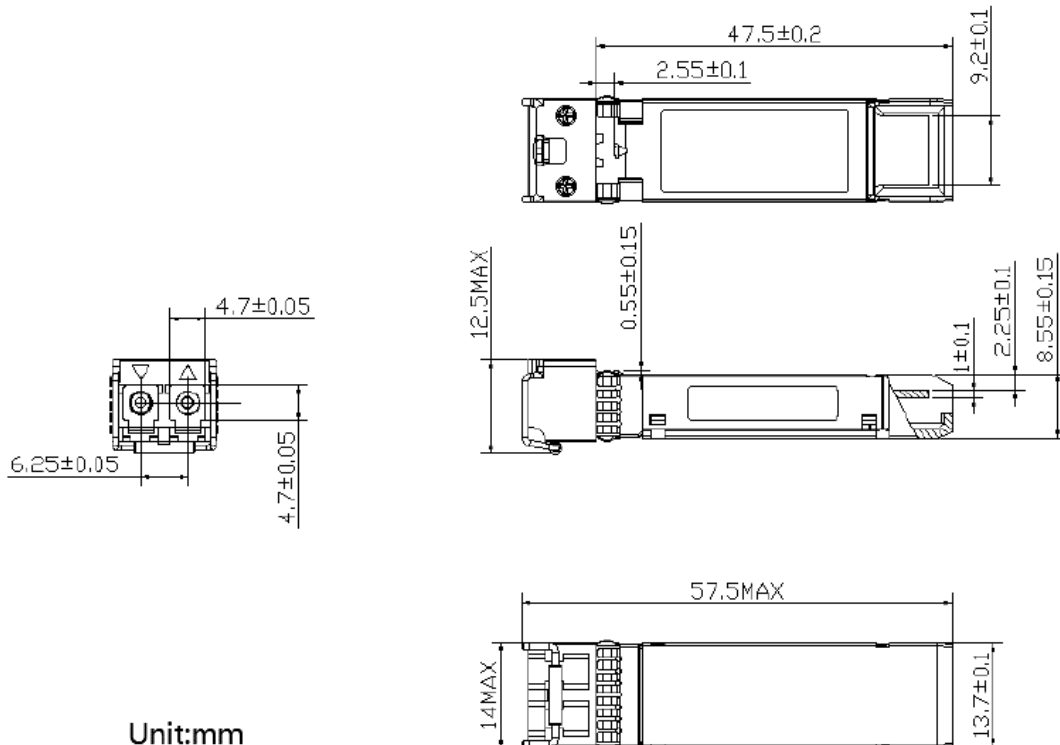

OptioConnect

Innovation for the Future of High-Speed Networking

Who We Are

OptioConnect is reshaping the landscape of communication and high-speed networking through intelligent technology. With a core focus on cutting edge technology, we deliver smarter fiber optic solutions for enterprise networks, data centers, and next-gen telecom infrastructures.

What We Do

At OptioConnect, we fuse advanced engineering with intelligent automation to drive the future of networking. Our AI-integrated solutions are designed to optimize performance and streamline operations with:

- Superior Performance
- Network and traffic optimization
- Intelligent energy management
- Seamless OEM compatibility
- Scalable cost-efficiency

Smarter Networks by Design

Innovation isn't just a goal—it's our process. We embed AI and machine learning across our R&D and product lines, enabling adaptive performance, automated tuning, and faster deployment cycles. The result? Networks that don't just work—they learn, evolve, and outperform.

Our Team

Our engineers, data scientists, and network architects bring decades of experience and a future-focused mindset. We provide hands-on support with intelligent insights that turn complex challenges into simple solutions.

Our Mission

To deliver AI-enhanced connectivity that reduces cost, increases speed, and maximizes efficiency—empowering our partners to operate at the forefront of a rapidly evolving digital world.

Let's Connect

Discover how OptioConnect's intelligent infrastructure solutions can power your network's next leap forward.

www.optioconnect.com | info@optioconnect.com

