

OSFP-2X400G-VR4-P-C

Juniper Networks® OSFP-2X400G-VR4-P Compatible TAA 800GBase-VR4 PAM4 OSFP-IHS Transceiver (MMF, 850nm, 50m, 2xMPO-12, DOM, CMIS 5.0)

Features:

- OSFP MSA Compliant
- Supports 850Gbps
- 8x53.125GBd (PAM4) Electrical Interface
- Dual MPO-12 Connector APC
- Commercial Temperature: 0 to 70 Celsius
- VCSEL Transmitter
- PIN and TIA Array on the Receiver Side
- RoHS Compliant and Lead-Free



Applications:

- 2x400GBase Ethernet

Product Description

This Juniper Networks® compatible OSFP-IHS Transceiver provides 800GBase-VR4 throughput up to 50m over multi-mode fiber (MMF) PAM4 using a wavelength of 850nm via a 2xMPO-12 connector. It can operate at temperatures between 0 and 70C. Our transceiver is built to meet or exceed OEM specifications and is guaranteed to be 100% compatible with Juniper Networks®. It has been programmed, uniquely serialized, and tested for data-traffic and application to ensure that it will initialize and perform identically. All of our transceivers comply with Multi-Source Agreement (MSA) standards to provide seamless network integration. Additional product features include Digital Optical Monitoring (DOM) support which allows access to real-time operating parameters. This transceiver is Trade Agreements Act (TAA) compliant. We stand behind the quality of our products and proudly offer a limited lifetime warranty.

ProLabs' transceivers are RoHS compliant and lead-free.

TAA refers to the Trade Agreements Act (19 U.S.C. & 2501-2581), which is intended to foster fair and open international trade. TAA requires that the U.S. Government may acquire only "U.S.-made or designated country end products.")



Absolute Maximum Ratings

Parameter	Symbol	Min.	Typ.	Max.	Unit	Notes
Power Supply Voltage	Vcc	-0.5	3.3	3.6	V	
Storage Temperature	Tstg	-40		85	°C	
Operating Case Temperature	Tc	0		70	°C	1
Relative Humidity (non-condensing)	RH	5		85	%	
Fiber Length (OM3)				30	m	
Fiber Length (OM4)				50	m	

Notes:

1. The position of the case temperature measurement is shown in the Mechanical Specifications section.
2. Exceeding the Absolute Maximum Ratings table may cause permanent damage to the device. This is just an emphasized rating and does not involve the functional operation of the device that exceeds the specifications of this technical specification under these or other conditions. Long-term operation under Absolute Maximum Ratings will affect the reliability of the device.

Electrical Characteristics

Parameter	Symbol / Test Point	Min.	Typ.	Max.	Unit	Notes
Power Supply Voltage	Vcc	3.135	3.3	3.465	V	
Power Supply Total Current				3190	mA	
Power Supply Noise				25	mVpp	1
Receiver Differential Data Output Load			100		Ohm	
Transceiver Power Consumption				14	W	
Transceiver Power Supply Total Current				4242	mA	
AC Coupling Internal Capacitor			0.1		μF	
High-Speed Electrical Input Characteristics						
Signaling Rate Per Lane (Range)	TP1		53.125± 100ppm		GBd	
Differential Peak-Peak Input Voltage Tolerance	TP1a	750			mV	2
Peak-to-Peak AC Common-Mode Voltage Tolerance	Low-frequency, VCM_{LF}	TP1a	32		mV	
	Full-band, VCM_{FB}	TP1a	80		mV	
Differential-Mode to Common-Mode Return Loss, RL_{cd}	TP1		Equation (120G-2)		dB	3
Effective Return Loss, ERL	TP1		8.5		dB	
Differential Termination Mismatch	TP1			10	%	
Single-Ended Voltage Tolerance Range	TP1a	-0.4		3.3	V	
DC Common-Mode Output Voltage	TP1	-350		2850	mV	4
Module Stressed Input Tolerance	TP1a					5

Pattern Generator Transition Time (Target)				9		ps	
Applied Peak-Peak Sinusoidal Jitter				Table 162-17			6
Eye Height (Target)				15		mV	
Vertical Eye Closure			12		12.5	dB	
Crosstalk Differential Peak-Peak Voltage				750		mV	
Crosstalk Transition Time	Short Mode			10		ps	
	Long Mode			15		ps	
High-Speed Electrical Output Characteristics							
Signaling Rate Per Lane (Range)		TP4		53.125±100ppm		GBd	
Peak-to-Peak AC Common-Mode Voltage	Low-frequency, VCM_{LF}	TP4			32	mV	
	Full-band, VCM_{FB}	TP4			80	mV	
Differential Peak-to-Peak Output Voltage	Short Mode	TP4			600	mV	
	Long Mode	TP4			845	mV	
Eye Height		TP4	15			mV	
Vertical Eye Closure, VEC		TP4			12	dB	
Common to Differential Mode Conversion Return Loss, $RLdc$		TP4	Equation (120G-1)			mV	7
Effective Return Loss, ERL		TP4	8.5			dB	
Differential Termination Mismatch		TP4			10	%	
Transition Time (20% ~80%)		TP4	8.5			ps	
DC Common Mode Voltage Tolerance		TP4	-350		2850	mV	8

Notes:

1. Power Supply Noise is defined as the peak-to-peak noise amplitude over the frequency range at the host supply side of the recommended power supply filter with the module and recommended filter in place. Voltage levels including peak-to-peak noise are limited to the recommended operating range of the associated power supply. See recommended power supply filter figure on page 9.
2. With the exception to 120E.3.1.2 that the pattern is PRBS31Q or scrambled idle.
3. Equation (120G-2) refers to IEEE 803ck.
4. DC common mode voltage generated by the host. Specification includes effects of ground offset voltage.
5. Meets BER specified in 120G.1.1 of IEEE 802.3ck.
6. Table 162-17 refers to IEEE 802.3ck.
7. Equation (120G-1) refers to IEEE 802.3ck.
8. DC common mode voltage generated by the host. Specification includes effects of ground offset voltage.

High-Speed Optical Characteristics

Parameter	Symbol	Min.	Typ.	Max.	Unit	Notes
Transmitter (@TP2 Test Point)						
Signaling Speed Per Lane	DR		53.125± 100ppm		Gbps	
Modulation Format		PAM4				
Center Wavelength	λ_C	842		868	nm	
RMS Spectral Width	$\Delta\lambda_{rms}$			0.65	nm	1
Average Launch Power, Each Lane	Pavg	-4.6		4	dBm	
Outer Optical Modulation Amplitude (OMA _{outer}), Each Lane (Max)	POMA			3.5	dBm	
Outer Optical Modulation Amplitude (OMA _{outer}), Each Lane (min) for Max (TECQ, TDECQ) ≤1.8dB	POMA	-2.6			dBm	
Outer Optical Modulation Amplitude (OMA _{outer}), Each Lane (min) for 1.8<Max (TECQ, TDECQ) ≤4.4dB	POMA	-4.4+max (TECQ, TDECQ)			dBm	
Transmitter and Dispersion Eye Closure for PAM4 (TDECQ), each Lane	TDECQ			4.4	dB	
Transmitter Eye Closure for PAM4 (TECQ), each Lane	TECQ			4.4	dB	
Overshoot/Undershoot				29	%	
Transmitter Power Excursion, each Lane				2.3	dBm	
Extinction Ratio, each Lane	ER	2.5			dB	
Transmitter Transition Time, each Lane				17	ps	
Average Launch Power of OFF Transmitter, each Lane	Poff			-30	dBm	
RIN ₁₂ OMA	RIN ₁₂ OMA			-132	dB/Hz	
Optical Return Loss Tolerance	ORL			14	dB	
Encircled Flux	EF		≥86% at 19 μm ≤30% at 4.5 μm			2
Receiver (@TP3 Test Point)						
Signaling Speed Per Lane			53.125± 100ppm		Gbps	
Modulation Format		PAM4				
Center Wavelength	λ	842		948	nm	
Damage Threshold		5			dBm	3
Average Receiver Power, each Lane		-6.3		4	dBm	4
Receiver Reflectance				-15	dB	
Receiver Sensitivity (OMA _{outer}) for TECQ≤1.8dB	SEN			-4.4	dBm	
Receiver Sensitivity (OMA _{outer}) for 1.8<TECQ≤4.4dB	SEN			-6.2+TECQ	dBm	
LOS Assert	LOSA	-15			dBm	
LOS De-Assert	LOSD			-9	dBm	

Stressed Receiver Sensitivity (OMA_{outer}), each Lane			-1.8	dBm	dB	5
Conditions of Stressed Receiver Sensitivity Test (Note 6)						
Stressed Eye Closure for PAM4 (SECQ), Lane Under Test			4.4		dB	
OMA_{outer} of Each Aggressor Lane			3.5		dBm	

Notes:

1. RMS spectral width is the standard deviation of the spectrum.
2. If measured into type A1a.2 or type A1a.3, or A1a.4, 50um fiber, in accordance with IEC61280-1-4.
3. The receiver shall be able to tolerate, without damage, continuous exposure to an optical input signal having this average power level on one lane. The receiver does not have to operate correctly at this input power.
4. Average receive power, each lane (min) is informative and not the principal indicator of signal strength. A received power below this value cannot be compliant; however, a value above this does not ensure compliance.
5. Measured with conformance test signal at TP3 (see 167.8.14) for the BER specified in 167.1.1.
6. These test conditions are for measuring stressed receiver sensitivity. They are not characteristics of the receiver.

Pin Descriptions

Pin	Logic	Symbol	Name/Description	Plug Sequence	Notes
1		GND	Module Ground.	1	1
2	CML-I	Tx2+	Transmitter Non-Inverted Data.	3	
3	CML-I	Tx2-	Transmitter Inverted Data.	3	
4		GND	Module Ground.	1	1
5	CML-I	Tx4+	Transmitter Non-Inverted Data.	3	
6	CML-I	Tx4-	Transmitter Inverted Data.	3	
7		GND	Module Ground.	1	1
8	CML-I	Tx6+	Transmitter Non-Inverted Data.	3	
9	CML-I	Tx6-	Transmitter Inverted Data.	3	
10		GND	Module Ground.	1	1
11	CML-I	Tx8+	Transmitter Non-Inverted Data.	3	
12	CML-I	Tx8-	Transmitter Inverted Data.	3	
13		GND	Module Ground.	1	1
14	LVC MOS-I/O	SCL	2-Wire Serial Interface Clock.	3	2
15		Vcc	+3.3V Power Supply.	2	
16		Vcc	+3.3V Power Supply.	2	
17	Multi-Level	LPWn/PRSn	Low-Power Mode/Module Present.	3	
18		GND	Module Ground.	1	1
19	CML-O	Rx7-	Receiver Inverted Data.	3	

20	CML-O	Rx7+	Receiver Non-Inverted Data.	3	
21		GND	Module Ground.	1	1
22	CML-O	Rx5-	Receiver Inverted Data.	3	
23	CML-O	Rx5+	Receiver Non-Inverted Data.	3	
24		GND	Module Ground.	1	1
25	CML-O	Rx3-	Receiver Inverted Data.	3	
26	CML-O	Rx3+	Receiver Non-Inverted Data.	3	
27		GND	Module Ground.	1	1
28	CML-O	Rx1-	Receiver Inverted Data.	3	
29	CML-O	Rx1+	Receiver Non-Inverted Data.	3	
30		GND	Module Ground.	1	1
31		GND	Module Ground.	1	1
32	CML-O	Rx2+	Receiver Non-Inverted Data.	3	
33	CML-O	Rx2-	Receiver Inverted Data.	3	
34		GND	Module Ground.	1	1
35	CML-O	Rx4+	Receiver Non-Inverted Data.	3	
36	CML-O	Rx4-	Receiver Inverted Data.	3	
37		GND	Module Ground.	1	1
38	CML-O	Rx6+	Receiver Non-Inverted Data.	3	
39	CML-O	Rx6-	Receiver Inverted Data.	3	
40		GND	Module Ground.	1	1
41	CML-O	Rx8+	Receiver Non-Inverted Data.	3	
42	CML-O	Rx8-	Receiver Inverted Data.	3	
43		GND	Module Ground.	1	1
44	Multi-Level	INT/RSTn	Module Input/Module Reset.	3	
45		Vcc	+3.3V Power Supply.	2	
46		Vcc	+3.3V Power Supply.	2	
47	LVC MOS-I/O	SDA	2-Wire Serial Interface Data.	3	2
48		GND	Module Ground.	1	1
49	CML-I	Tx7-	Transmitter Inverted Data.	3	
50	CML-I	Tx7+	Transmitter Non-Inverted Data.	3	
51		GND	Module Ground.	1	1
52	CML-I	Tx5-	Transmitter Inverted Data.	3	
53	CML-I	Tx5+	Transmitter Non-Inverted Data.	3	
54		GND	Module Ground.	1	1
55	CML-I	Tx3-	Transmitter Inverted Data.	3	
56	CML-I	Tx3+	Transmitter Non-Inverted Data.	3	

57		GND	Module Ground.	1	1
58	CML-I	Tx1-	Transmitter Inverted Data.	3	
59	CML-I	Tx1+	Transmitter Non-Inverted Data.	3	
60		GND	Module Ground.	1	1

Notes:

- OSFP uses common ground (GND) for all signals and supply (power). All are common within the OSFP module, and all module voltages are referenced to this potential unless otherwise noted.
- Open-Drain with pull-up resistor on the host.

Electrical Pad Layout

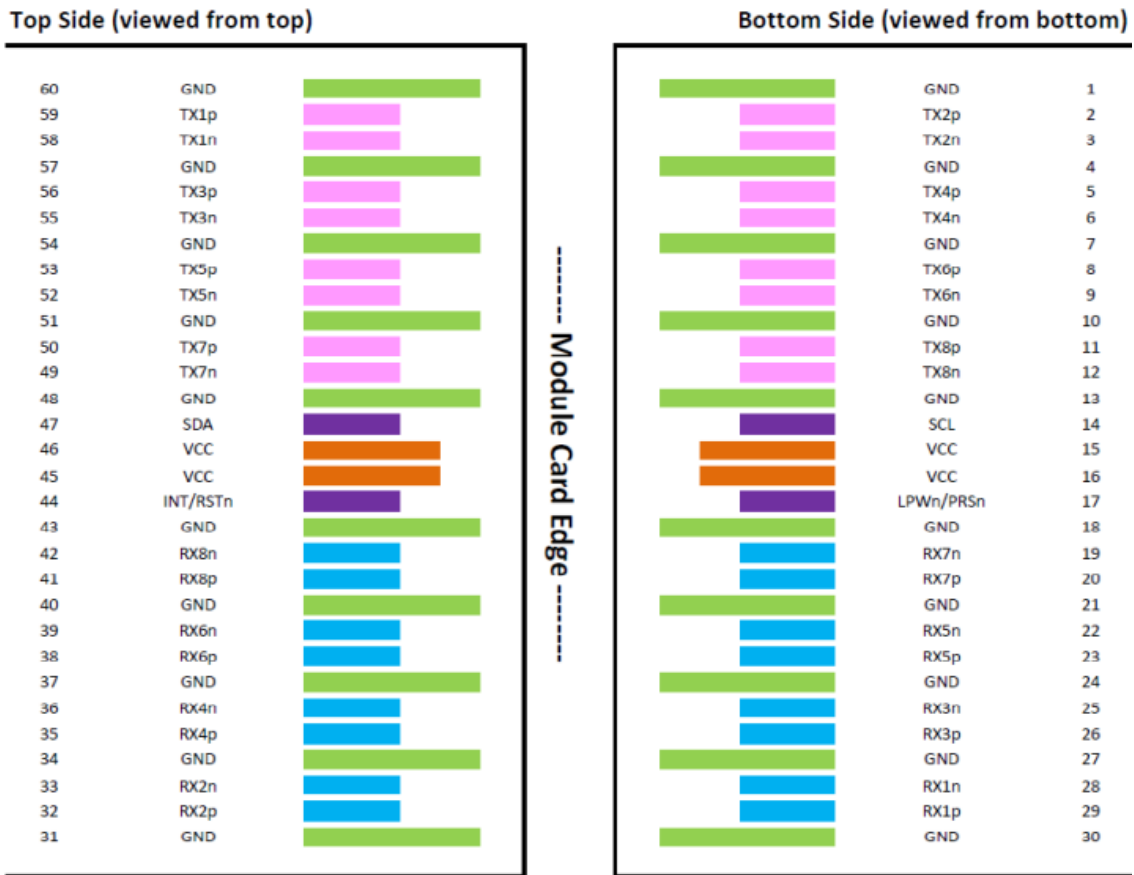

INT/RSTn

INT/RSTn is a dual function signal that allows the module to raise an interrupt to the host and also allows the host to reset the module. The circuit shown in OSFP MSA Figure 11-3 enables multi-level signaling to provide direct signal control in both directions. Reset is an active low signal on the host which is translated to an active-low signal on the module. Interrupt is an active-high signal on the module which gets translated to an active-low signal on the host.

The INT/RSTn signal operates in 3 voltage zones to indicate the state of Reset for the module and Interrupt for the host. The figure below shows these 3 zones. The host uses a voltage reference at 2.5 volts to determine the state of the H_INTn signal and the module uses a voltage reference at 1.25V to determine the state of the M_RSTn signal.

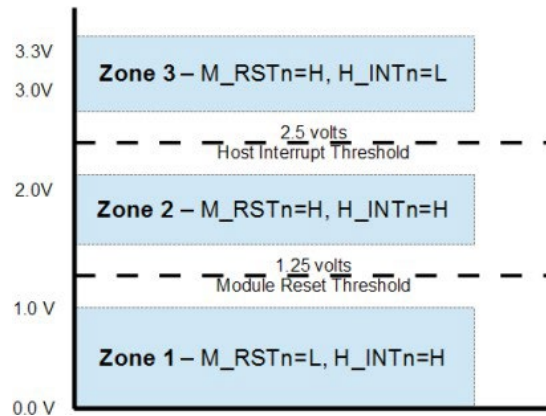

LPWn/PRSn

LPWn/PRSn is a dual function signal that allows the host to signal Low Power mode and the module to indicate Module Present. The circuit shown in OSFP MSA Figure 11-5 enables multi-level signaling to provide direct signal control in both directions. Low Power mode is an active-low signal on the host which gets converted to an active-low signal on the module. Module Present is controlled by a pull-down resistor on the module which gets converted to an active-low logic signal on the host.

The LPWn/PRSn signal operates in 3 voltage zones to indicate the state of Low Power mode for the module and Module Present for the host. The figure below shows these 3 zones. The host uses a voltage reference at 2.5 volts to determine the state of the H_PRSn signal and the module uses a voltage reference at 1.25V to determine the state of the M_LPWn signal.

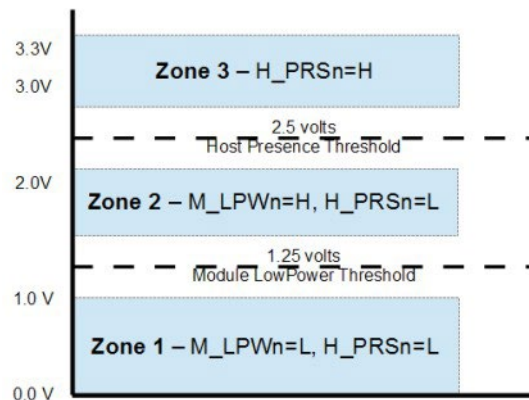

Recommended Host Board Power Supply Filter

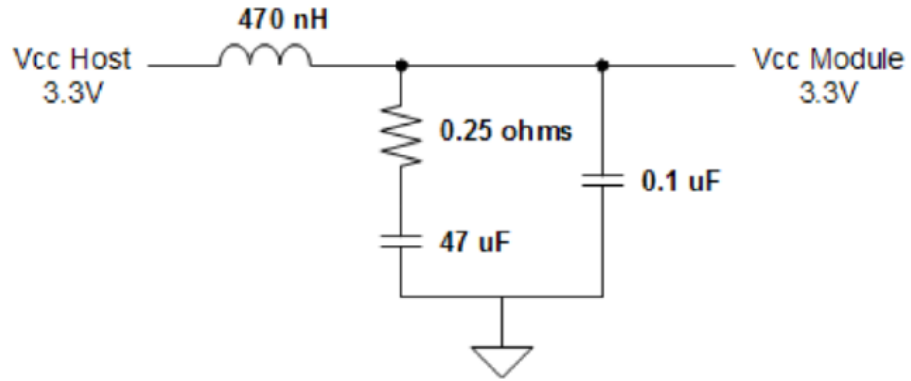

Transceiver Block Diagram

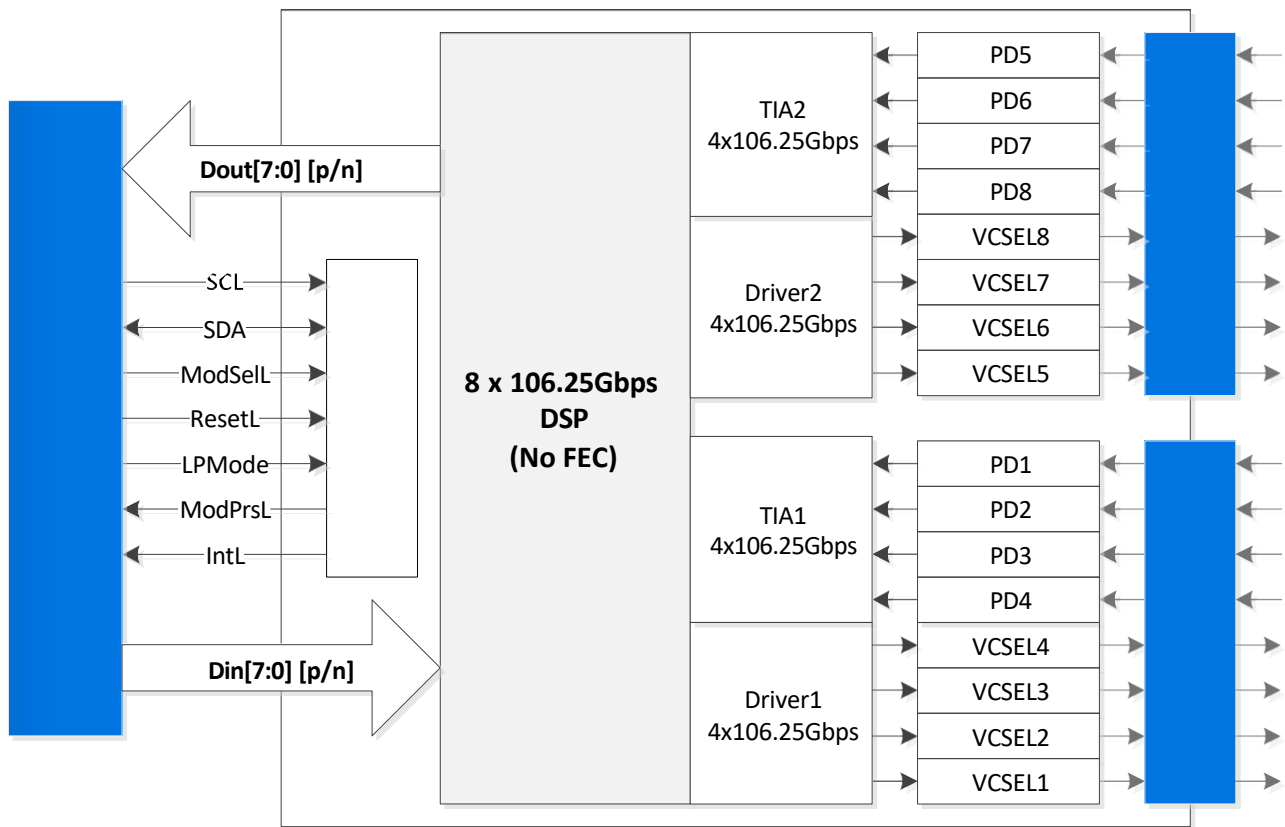

Application Reference Diagram

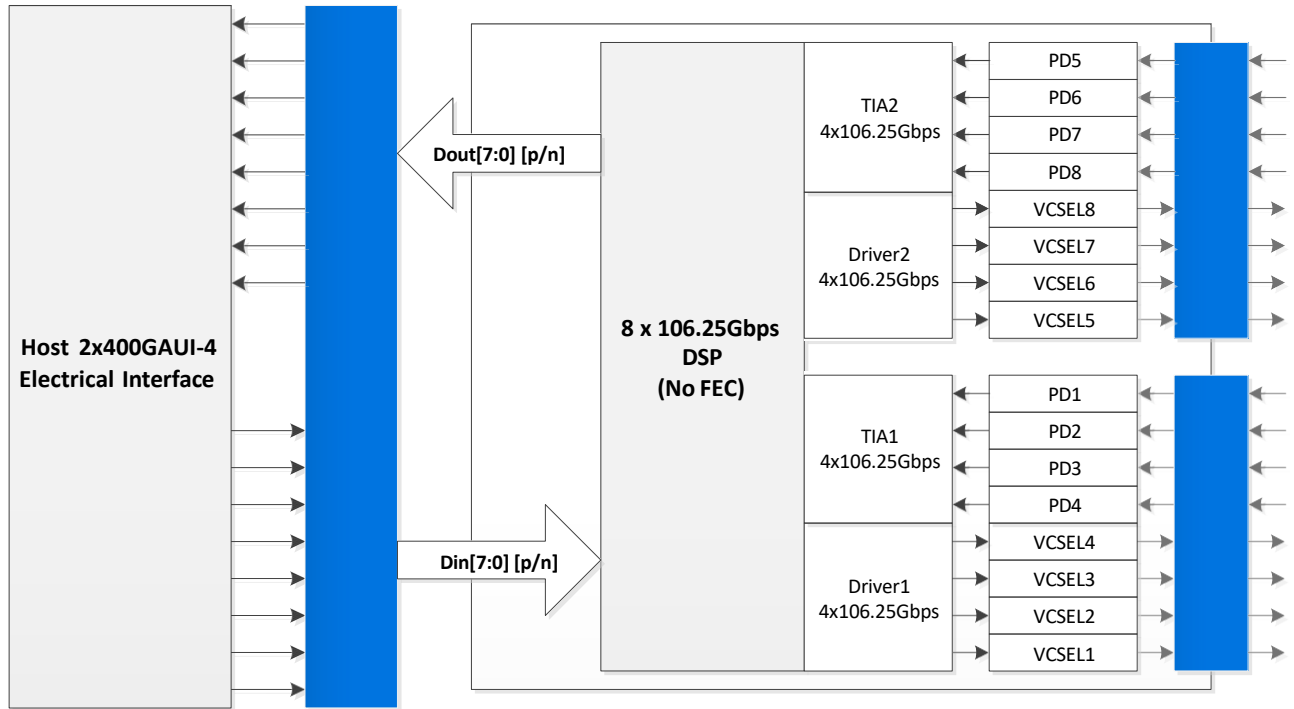

Mechanical Specifications

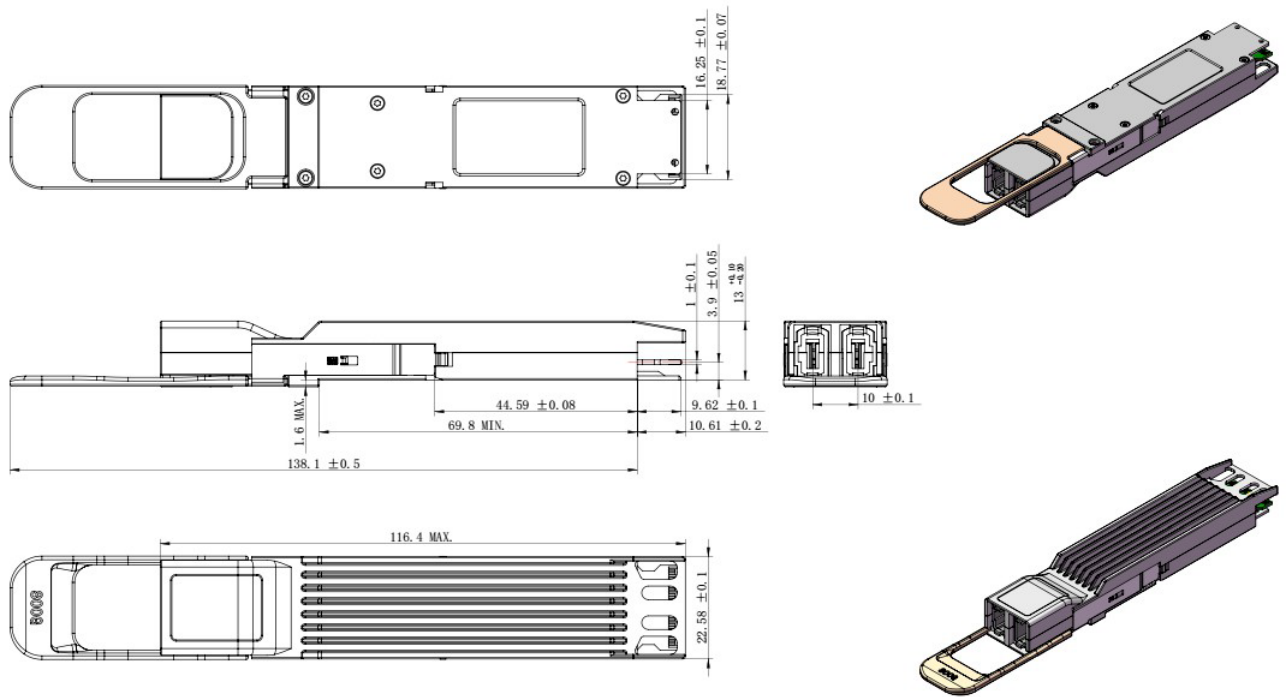

Case Temperature Measurement Point

The bellow picture shows the location of the hottest spot for measuring module case temperature. In addition, the digital diagnostic monitors (DDM) temperature is also calibrated to this spot.

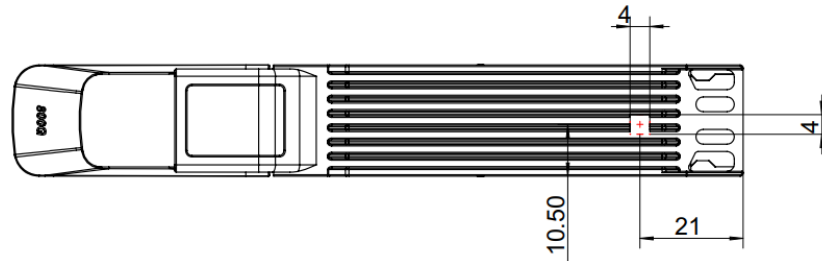

Notes:

1. All dimensions are in mm.

Module Optical Interface (Looking into the Optical Port)

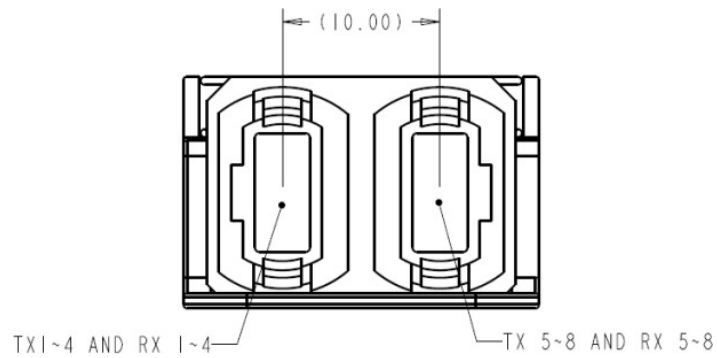

Notes:

1. The optical interface port is a male dual MPO-12 connector as specified in IEC 61754-7-1 mates with a standard type MPO-12 female plug connector with down-angled interface.

About ProLabs

Our extensive experience comes as standard. For over 20 years ProLabs has delivered optical connectivity solutions that give our customers freedom and choice through our ability to provide seamless interoperability. At the heart of our company is the ability to provide state-of-the-art optical transport and connectivity solutions that are compatible with more than 100 optical switching and transport platforms.

A Complete Portfolio of Network Solutions

ProLabs is focused on innovations in optical transport and connectivity. The combination of our knowledge of optics and networking equipment enables ProLabs to be your single source for optical transport and connectivity solutions from 100Mb to 1.6T while providing innovative solutions that increase network efficiency. We provide the optical connectivity expertise that is compatible with and enhances your switching and transport equipment.

The Trusted Partner

Customer service is our number one value. ProLabs has invested in people, labs and manufacturing capacity to ensure compatible products, and immediate answers to your questions. With Engineering and Manufacturing offices in the U.K. and U.S. augmented by field offices throughout the U.S., U.K. and Asia, ProLabs is able to be our customers best advocate 24 hours a day.



Contact Information

ProLabs US

Email: sales@prolabs.com

Telephone: 952-852-0252

ProLabs UK

Email: salessupport@prolabs.com

Telephone: +44 1285 719 600