

## QDD-400G-ER4-30-C

Juniper Networks® QDD-400G-ER4-30 Compatible TAA 400GBase-ER4 PAM4QSFP-DD Transceiver (SMF, 1310nm, 30km, LC, DOM, CMIS 4.0)

### Features:

- Compliant with IEEE Std 802.3cd
- Compliant with QSFP-DD MSA
- Compliant with QSFP-DD Management Interface

### Specifications

- Duplex LC
- 53.125GBd PAM4x4 Cooled EML
- 26.5625GBd PAM4x8 Electrical Connector
- Single 3.3V Power Supply
- Up to 30km on SMF
- Operating Temperature: 0 to 70 Celsius
- RoHS Compliant and Lead-Free



### Applications:

- 400GBase Ethernet
- Access and Enterprise

### Product Description

This Juniper Networks® QDD-400G-ER4-30 compatible QSFP-DD transceiver provides 400GBase-ER4 throughput up to 30km over single-mode fiber (SMF) using a wavelength of 1310nm via an LC connector. It is guaranteed to be 100% compatible with the equivalent Juniper Networks® transceiver. This easy to install, hot swappable transceiver has been programmed, uniquely serialized and data-traffic and application tested to ensure that it will initialize and perform identically. Digital optical monitoring (DOM) support is also present to allow access to real-time operating parameters. It is built to meet or exceed the specifications of Juniper Networks® to ensure seamless network integration. We stand behind the quality of our products and proudly offer a limited lifetime warranty.

ProLabs' transceivers are RoHS compliant and lead-free.

TAA refers to the Trade Agreements Act (19 U.S.C. & 2501-2581), which is intended to foster fair and open international trade. TAA requires that the U.S. Government may acquire only "U.S.-made or designated country end products.")



## Absolute Maximum Ratings

Parameter	Symbol	Min.	Typ.	Max.	Unit	Notes
Storage Temperature	Tstg	-40		85	°C	
Operating Case Temperature	Tc	0	25	70	°C	
Relative Humidity	RH	15		85	%	
Supply Voltage	Vcc	-0.5		4.0	V	
Data Rate Per Channel			53.125		Gbps	
Modulation Format			PAM4			

## Electrical Characteristics

Parameter	Symbol	Min.	Typ.	Max.	Unit	Notes
Power Supply Voltage	Vcc	3.135	3.3	3.465	V	
Power Supply Current	Icc			3.8	A	
Power Dissipation	P <sub>DISS</sub>			12	W	
Transmitter						
Input Differential Impedance	ZIN		100		Ω	
Differential Data Input Swing	VIN,pp	180		900	mVp-p	
Receiver						
Output Differential Impedance	ZOUT		100		Ω	
Differential Data Input Swing	VOUT,pp	300		850	mVp-p	1

### Notes:

1. Internally AC coupled but requires an external 100Ω differential load termination.

## Optical Characteristics

Parameter	Symbol	Min.	Typ.	Max.	Unit	Notes
<b>Transmitter</b>						
<b>Center Wavelength</b>	$\lambda_C$	1304.06		1305.1	nm	1
		1306.33		1307.38		
		1308.61		1309.66		
		1310.9		1311.96		
<b>Side-Mode Suppression Ratio</b>	SMSR	30			dB	
<b>Total Average Launch Power</b>	PT			10	dBm	
<b>Average Launch Power Per Lane</b>	P	1.5		7.1	dBm	
<b>Outer Optical Modulation Amplitude Per Lane (Min.)</b>	OMA <sub>outer</sub>	4.5		7.9	dBm	
<b>Transmitter and Dispersion Eye Closure for PAM4 (TDECQ) Per Lane</b>	TDECQ			3.9	dB	
<b>Transmitter Eye Closure for PAM4 (TECQ) Per Lane</b>	TECQ			3.9	dB	
<b>TDECQ-TECQ</b>				2.7	dB	
<b>Extinction Ratio</b>	ER	6			dB	
<b>Average Launch Power of Off Transmitter Per Lane</b>	P <sub>off</sub>			-30	dBm	
<b>Optical Return Loss Tolerance</b>	ORLT			15	dB	
<b>Transmitter Reflectance</b>				-26	dB	
<b>Receiver</b>						
<b>Center Wavelength</b>	$\lambda_C$	1304.06		1305.1	nm	
		1306.33		1307.38		
		1308.61		1309.66		
		1310.9		1311.96		
<b>Average Receiver Power Per Lane (P<sub>avg</sub>)</b>		-16.2		-3.4	dBm	
<b>Receiver Overload (Average Power) Per Lane</b>		-3.4			dBm	
<b>Damage Threshold</b>		-2.4			dBm	
<b>Receive Power Per Lane (OMA<sub>outer</sub>)</b>				-2.6	dBm	2
<b>Receiver Sensitivity Per Lane (OMA<sub>outer</sub>)</b>				-14	dBm	2
<b>Stressed Receiver Sensitivity Per Lane (OMA<sub>outer</sub>)</b>				-11.5	dBm	
<b>LOS Assert</b>	LOSA			-20	dBm	
<b>LOS De-Assert</b>	LOSD			-17	dBm	
<b>LOS Hysteresis</b>		0.5			dB	

### Notes:

1. The typical wavelengths compliant with 1310nm nLWDM wavelength grids.
2. Measured with PRBS31Q test pattern @53.125Gbps, PAM4, and BER<2.4E<sup>-4</sup>.

## Pin Descriptions

Pin	Symbol	Name/Description	Notes
1	GND	Module Ground.	1
2	Tx2-	Transmitter Inverted Data Input.	
3	Tx2+	Transmitter Non-Inverted Data Output.	
4	GND	Module Ground.	1
5	Tx4-	Transmitter Inverted Data Input.	
6	Tx4+	Transmitter Non-Inverted Data Output.	
7	GND	Module Ground.	1
8	ModSelL	Module Select.	
9	ResetL	Module Reset.	
10	VccRx	+3.3V Receiver Power Supply.	2
11	SCL	2-Wire Serial Interface Clock.	
12	SDA	2-Wire Serial Interface Data.	
13	GND	Module Ground.	1
14	Rx3+	Receiver Non-Inverted Data Output.	
15	Rx3-	Receiver Inverted Data Output.	
16	GND	Module Ground.	1
17	Rx1+	Receiver Non-Inverted Data Output.	
18	Rx1-	Receiver Inverted Data Output.	
19	GND	Module Ground.	1
20	GND	Module Ground.	1
21	Rx2-	Receiver Inverted Data Output.	
22	Rx2+	Receiver Non-Inverted Data Output.	
23	GND	Module Ground.	1
24	Rx4-	Receiver Inverted Data Output.	
25	Rx4+	Receiver Non-Inverted Data Output.	
26	GND	Module Ground.	1
27	ModPrsL	Module Present.	
28	IntL	Interrupt.	
29	VccTx	+3.3V Transmitter Power Supply.	2
30	Vcc1	+3.3V Power Supply.	2
31	LPMODE	Low-Power Mode.	
32	GND	Module Ground.	1
33	Tx3+	Transmitter Non-Inverted Data Input.	
34	Tx3-	Transmitter Inverted Data Output.	
35	GND	Module Ground.	1
36	Tx1+	Transmitter Non-Inverted Data Input.	
37	Tx1-	Transmitter Inverted Data Output.	
38	GND	Module Ground.	1
39	GND	Module Ground.	1

40	Tx6-	Transmitter Inverted Data Input.	
41	Tx6+	Transmitter Non-Inverted Data Output.	
42	GND	Module Ground.	1
43	Tx8-	Transmitter Inverted Data Input.	
44	Tx8+	Transmitter Non-Inverted Data Output.	
45	GND	Module Ground.	1
46	Reserved	For Future Use.	3
47	VS1	Module Vendor-Specific 1.	3
48	VccRx1	+3.3V Receiver Power Supply.	2
49	VS2	Module Vendor-Specific 2.	3
50	VS3	Module Vendor-Specific 3.	3
51	GND	Module Ground.	1
52	Rx7+	Receiver Non-Inverted Data Output.	
53	Rx7-	Receiver Inverted Data Output.	
54	GND	Module Ground.	1
55	Rx5+	Receiver Non-Inverted Data Output.	
56	Rx5-	Receiver Inverted Data Output.	
57	GND	Module Ground.	1
58	GND	Module Ground.	1
59	Rx6-	Receiver Inverted Data Output.	
60	Rx6+	Receiver Non-Inverted Data Output.	
61	GND	Module Ground.	1
62	Rx8-	Receiver Inverted Data Output.	
63	Rx8+	Receiver Non-Inverted Data Output.	
64	GND	Module Ground.	1
65	NC	Not Connected.	3
66	Reserved	For Future Use.	3
67	VccTx1	+3.3V Transmitter Power Supply.	2
68	Vcc2	+3.3V Power Supply.	2
69	ePPS	Precision Time Protocol (PTP) Reference Clock Input.	3
70	GND	Module Ground.	1
71	Tx7+	Transmitter Non-Inverted Data Input.	
72	Tx7-	Transmitter Inverted Data Output.	
73	GND	Module Ground.	1
74	Tx5+	Transmitter Non-Inverted Data Input.	
75	Tx5-	Transmitter Inverted Data Output.	
76	GND	Module Ground.	1

**Notes:**

1. QSFP-DD uses common ground (GND) for all signals and power supplies. All are common within the QSFP-DD module, and all module voltages are referenced to this potential unless otherwise noted. Connect these directly to the host board signal common ground plane.

- VccRx, VccRx1, Vcc1, Vcc2, VccTx, and VccTx1 shall be applied concurrently. VccRx, VccRx1, Vcc1, Vcc2, VccTx, and VccTx1 may be internally connected within the module in any combination. The connector Vcc pins are each rated for a maximum current of 1000mA.
- All Vendor-Specific, Reserved, Not Connected, and ePPS (if not used) pins may be terminated with 50Ω to ground on the host. Pad 65 (Not Connected) shall be left unconnected within the module. Vendor-Specific and Reserved pads shall have an impedance to GND that is greater than 10kΩ and less than 100pF.

### Module Pad Layout

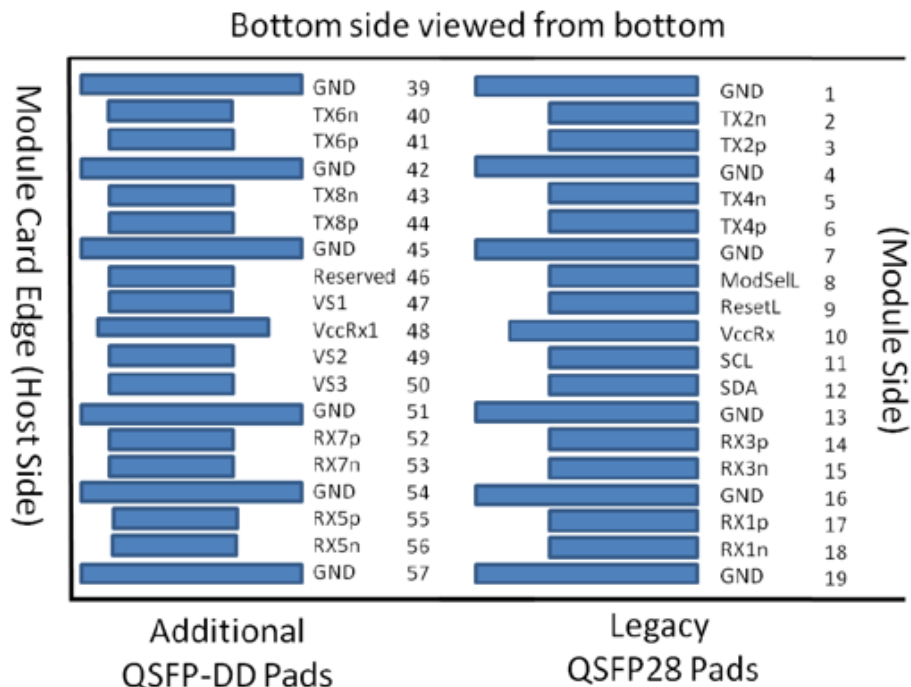
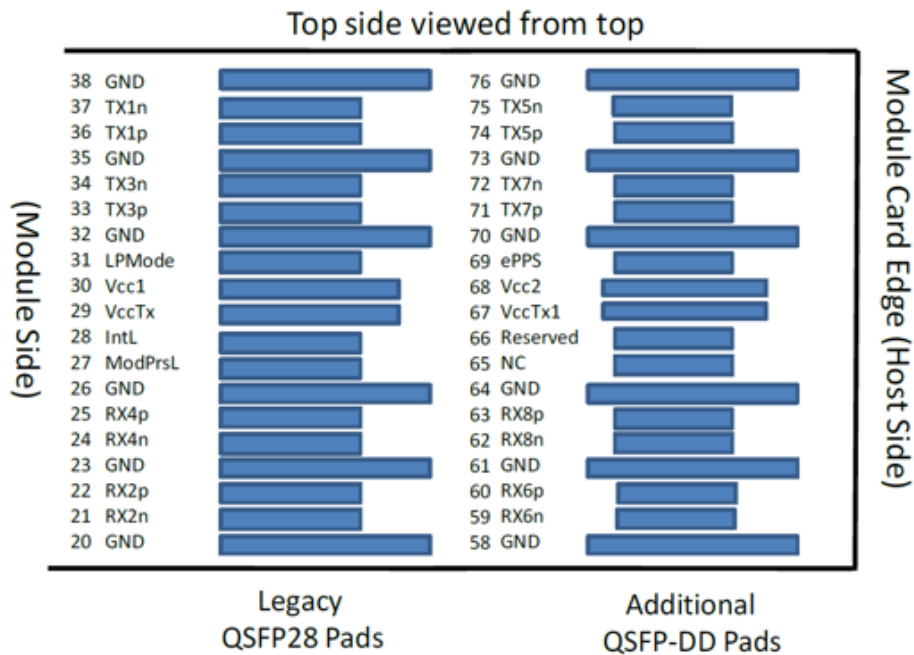

# Host Board Power Supply Filter Network

QSFP-DD Hardware Rev 4.0

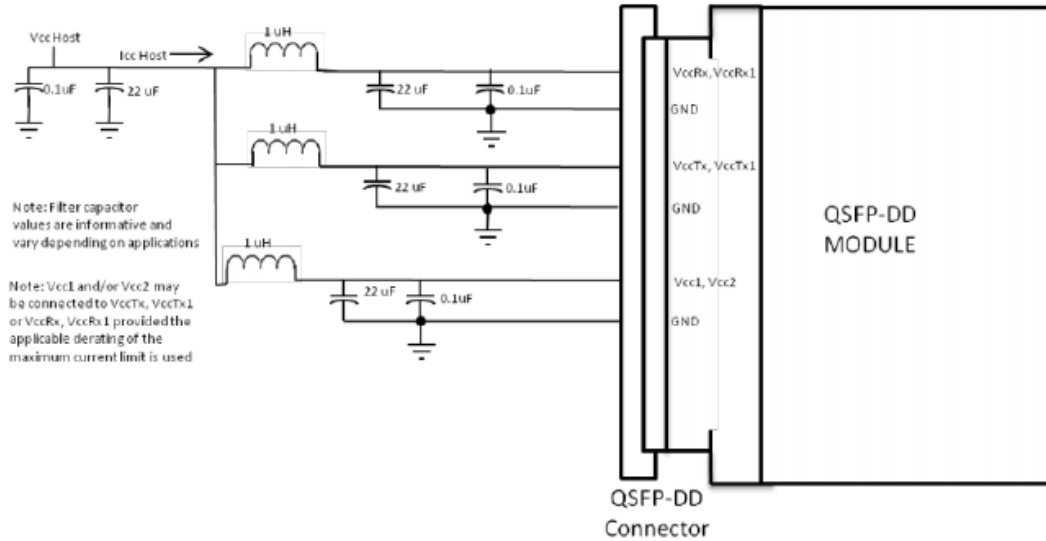

# Mechanical Specifications

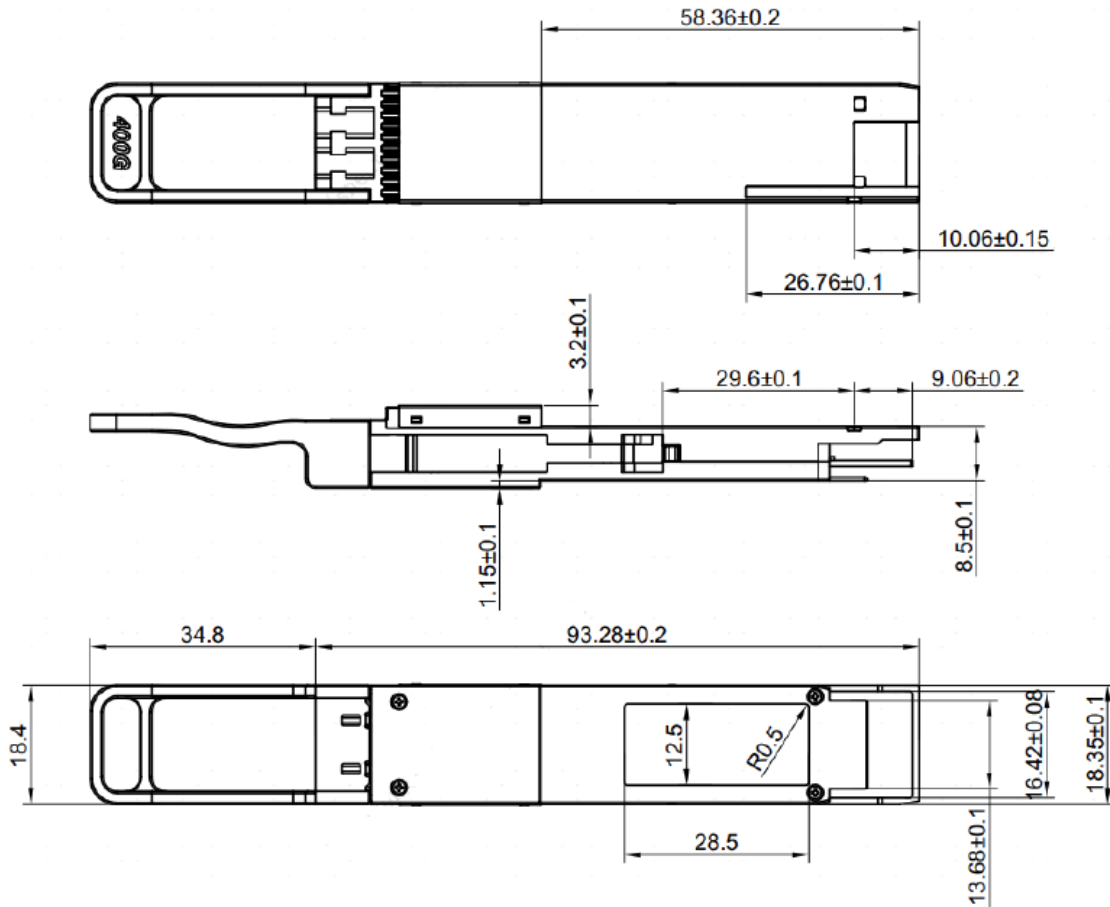

## About ProLabs

Our extensive experience comes as standard. For over 20 years ProLabs has delivered optical connectivity solutions that give our customers freedom and choice through our ability to provide seamless interoperability. At the heart of our company is the ability to provide state-of-the-art optical transport and connectivity solutions that are compatible with more than 100 optical switching and transport platforms.

## A Complete Portfolio of Network Solutions

ProLabs is focused on innovations in optical transport and connectivity. The combination of our knowledge of optics and networking equipment enables ProLabs to be your single source for optical transport and connectivity solutions from 100Mb to 1.6T while providing innovative solutions that increase network efficiency. We provide the optical connectivity expertise that is compatible with and enhances your switching and transport equipment.

## The Trusted Partner

Customer service is our number one value. ProLabs has invested in people, labs and manufacturing capacity to ensure compatible products, and immediate answers to your questions. With Engineering and Manufacturing offices in the U.K. and U.S. augmented by field offices throughout the U.S., U.K. and Asia, ProLabs is able to be our customers best advocate 24 hours a day.



## Contact Information

ProLabs US

Email: [sales@prolabs.com](mailto:sales@prolabs.com)

Telephone: 952-852-0252

ProLabs UK

Email: [salessupport@prolabs.com](mailto:salessupport@prolabs.com)

Telephone: +44 1285 719 600