

QSFP28-40/100GB-SRBD-J-AO

Juniper Networks® Compatible TAA 40/100GBase-SR1.2 Bidi QSFP28 Transceiver (MMF, 844nm to 918nm, 100m, LC, DOM) Rate Select

Features

- QSFP28 MSA Compliant
- Hot-Pluggable
- 100G and 40G Link Distances Up to 70m Over OM3, 100m Over OM4
- Operating Temperature: 0 to 70 Celsius
- RoHS Compliant and Lead-Free
- Dual Wavelength VCSEL Bi-Directional Optical Interface, PAM4 2x500Gbps 850nm/908nm



Applications

- 100GBase Ethernet

Product Description

This Juniper Networks® compatible QSFP28 transceiver provides 40/100GBase-BX SR1.2 throughput up to 100m over OM4 multi-mode fiber (MMF) using a wavelength of 844nm to 918nm via an LC connector. This bidirectional unit must be used with another transceiver or network appliance of complementing wavelengths. It can operate at temperatures between 0 and 70C. Our transceiver is built to meet or exceed OEM specifications and is guaranteed to be 100% compatible with Juniper Networks®. It has been programmed, uniquely serialized, and tested for data-traffic and application to ensure that it will initialize and perform identically. This transceiver is Trade Agreements Act (TAA) compliant. All of our transceivers comply with Multi-Source Agreement (MSA) standards to provide seamless network integration. Additional product features include Digital Optical Monitoring (DOM) support which allows access to real-time operating parameters. We stand behind the quality of our products and proudly offer a limited lifetime warranty.

AddOn's transceivers are RoHS compliant and lead-free.

TAA refers to the Trade Agreements Act (19 U.S.C. & 2501-2581), which is intended to foster fair and open international trade. TAA requires that the U.S. Government may acquire only "U.S.-made or designated country end products."



Absolute Maximum Ratings

Parameter	Symbol	Min.	Typ.	Max.	Unit	Notes
Storage Temperature	Tstg	-40		85	°C	
Operating Case Temperature	Tc	0	25	70	°C	
Relative Humidity – Storage (Non-Condensing)	RHstg	0		95	%	2
Relative Humidity – Operating (Non-Condensing)	RHc	0		85	%	2
Supply Voltage	Vcc	-0.5		3.6	V	
Signaling Speed Per Channel (4x25G NRZ)	S		25.78		Gbps	

Notes:

1. Exceeding the “Absolute Maximum Ratings” may cause irreversible damage to the device. The device is not intended to be operated under the condition of simultaneous “Absolute Maximum Ratings,” a condition which may cause irreversible damage to the device.
2. Non-condensing.

Electrical Characteristics

Parameter	Symbol	Min.	Typ.	Max.	Unit	Notes
Power Supply Voltage	Vcc	3.135	3.3	3.465	V	
Power Consumption	PC			4	W	
Transmitter						
Differential Input Voltage	VIN	200		900	mV	
Differential Input Impedance	ZIN		100		Ω	
Receiver						
Differential Output Voltage	VOUT			1200	mV	
Differential Output Impedance	ZOUT		100		Ω	
Timing Requirement of Control and Status I/O						
Tx Squelch De-Assert Time	toff_Txsq			1	s	
Rx Squelch De-Assert Time	toff_Rxsq			2	s	
Non-Volatile Memory Specification						
Complete Single or Sequential Write	twr			80	ms	
Soft Control and Status Timing Requirement						
Application or Rate Select Change Time	t_ratesel			600	ms	

Optical Characteristics

Parameter	Symbol	Min.	Typ.	Max.	Unit	Notes
Transmitter @ Test Point 2						
Center Wavelength	λ	844	850	863	nm	
		900	908	918	nm	
RMS Spectral Width	$\Delta\lambda$			0.6	nm	
				0.65	nm	
Optical Return Loss Tolerance	ORL			12	fB	
Average Launch Power Per Lane	POUT	-6.2		4	dBm	1
Optical Modulation Amplitude Per Lane	OMA	-4.2		3	dBm	
Extinction Ratio	ER	3			dB	
Launch Power in OMAouter Minus TDECQ Per Lane	OMA _{TDECQ}	-5.9			dB	
Optical Output with Tx Off	P _{Off}			-30	dBm	
Transmitter and Dispersion Eye Closure for PAM4 (TDECQ) Per Lane	TDECQ			4.9	dB	
Receiver @ Test Point 3						
Center Wavelength	λ	844	850	863	nm	
		900	908	918	nm	
Average Power at Receive Input Per Lane	PIN	-7.9		4	dBm	2
Receiver Power Per Lane (OMAouter)	PIN(OMA)	-5.9		3	dBm	
Unstressed Receiver Sensitivity (OMAouter) Per Lane	SEN			Max. (-6.6, SECQ-8)	dBm	3
Receiver Reflectance	RFL			-12	dB	
LOS Assert	LOSA	-30			dBm	
LOS De-Assert	LOSD			-5.9	dBm	
LOS Hysteresis	LOSH	0.5			dB	

Notes:

1. Average optical output.
2. A received power below this value cannot be compliant; however, a value above this does not ensure compliance.
3. Sensitivity where the BER=2.4E⁻⁴ measured with a PRBS 31Q test pattern @26.56GBaud.

Pin Descriptions

Pin	Symbol	Name/Description
1	GND	Module Ground.
2	Tx2-	Transmitter Inverted Data Input.
3	Tx2+	Transmitter Non-Inverted Data Input.
4	GND	Module Ground.
5	Tx4-	Transmitter Inverted Data Input.
6	Tx4+	Transmitter Non-Inverted Data Input.
7	GND	Module Ground.
8	ModSelL	Module Select.
9	ResetL	Module Reset.
10	VccRx	+3.3V Receiver DC Power Supply.
11	SCL	I2C Serial Clock.
12	SDA	I2C Serial Data.
13	GND	Module Ground.
14	Rx3+	Receiver Non-Inverted Data Output.
15	Rx3-	Receiver Inverted Data Output.
16	GND	Module Ground.
17	Rx1+	Receiver Non-Inverted Data Output.
18	Rx1-	Receiver Inverted Data Output.
19	GND	Module Ground.
20	GND	Module Ground.
21	Rx2-	Receiver Inverted Data Output.
22	Rx2+	Receiver Non-Inverted Data Output.
23	GND	Module Ground.
24	Rx4-	Receiver Inverted Data Output.
25	Rx4+	Receiver Non-Inverted Data Output.
26	GND	Module Ground.
27	ModPrsL	Module Present.
28	IntL	Interrupt.
29	VccTx	+3.3V Transmitter DC Power Supply.
30	Vcc1	+3.3V DC Power Supply.
31	LPMode	Low-Power Mode.
32	GND	Module Ground.
33	Tx3+	Transmitter Non-Inverted Data Input.
34	Tx3-	Transmitter Inverted Data Input.
35	GND	Module Ground.

36	Tx1+	Transmitter Non-Inverted Data Input.
37	Tx1-	Transmitter Inverted Data Input.
38	GND	Module Ground.

Electrical Pin-Out Details

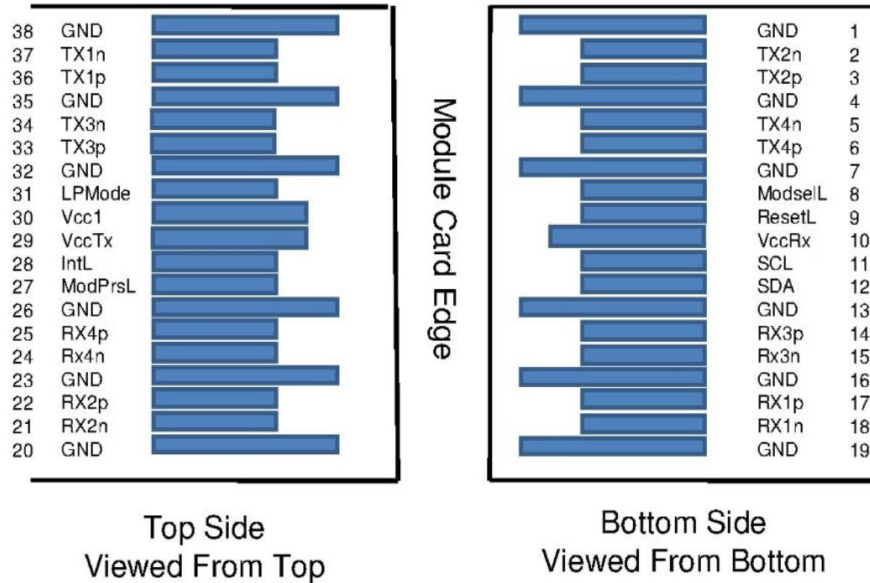

Block Diagram

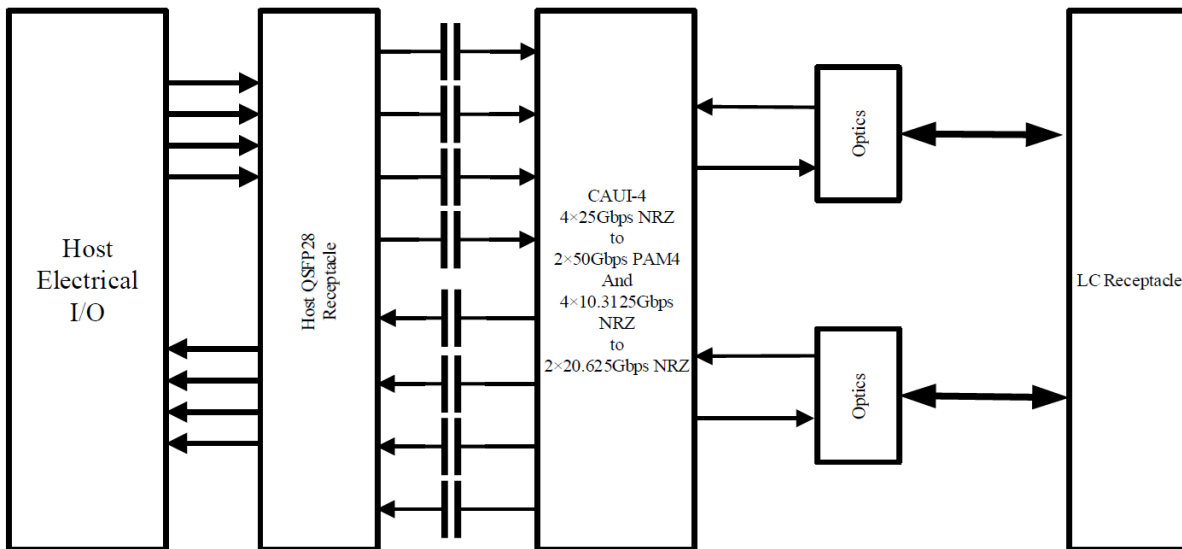

Mechanical Specifications

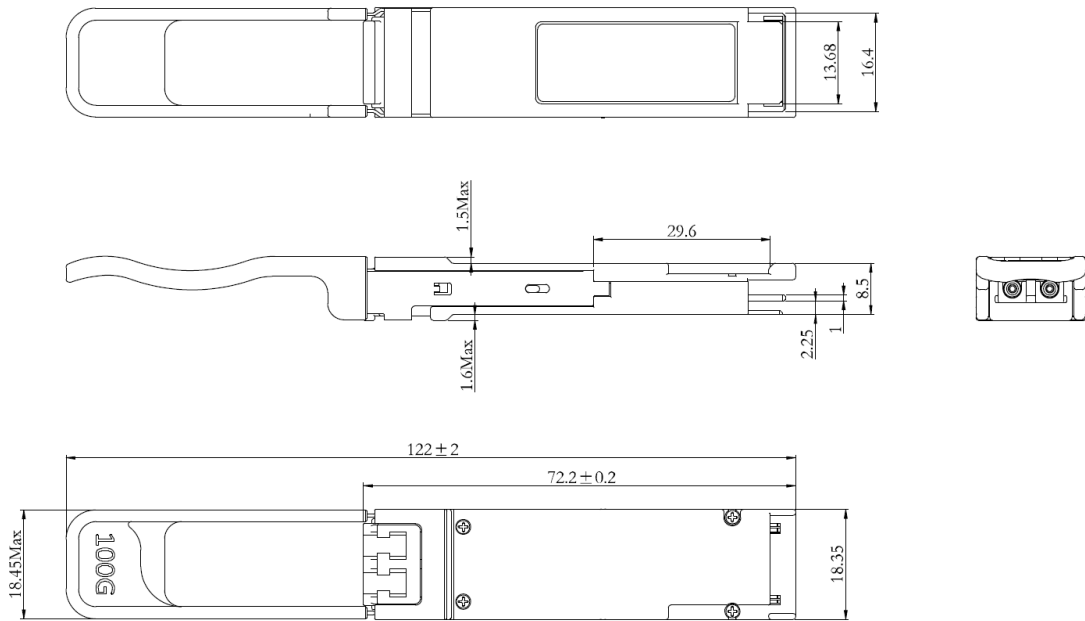

Notes:

1. Tolerance: ± 0.1 mm.
2. Others according with OSFP MSA.
3. Optical port according with Fiber Connector Specifications.

Optical Lane Assignment

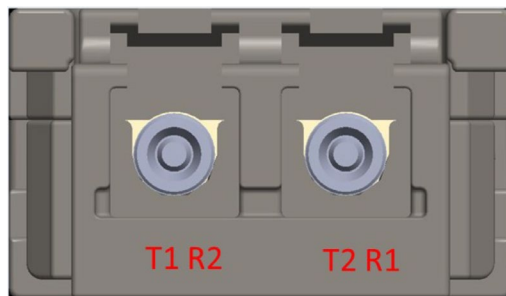

$\lambda 1$	844nm to 863nm	T1, R1
$\lambda 1$	900nm to 918nm	T2, R2

About AddOn Networks

In 1999, AddOn Networks entered the market with a single product. Our founders fulfilled a severe shortage for compatible, cost-effective optical transceivers that compete at the same performance levels as leading OEM manufacturers. Adhering to the idea of redefining service and product quality not previously had in the fiber optic networking industry, AddOn invested resources in solution design, production, fulfillment, and global support.

Combining one of the most extensive and stringent testing processes in the industry, an exceptional free tech support center, and a consistent roll-out of innovative technologies, AddOn has continually set industry standards of quality and reliability throughout its history.

Reliability is the cornerstone of any optical fiber network and is ingrained in AddOn's DNA. It has played a key role in nurturing the long-term relationships developed over the years with customers. AddOn remains committed to exceeding industry standards with certifications ranging from NEBS Level 3 to ISO 9001:2015 with every new development while maintaining the signature reliability of its products.



U.S. Headquarters

Email: sales@addonnetworks.com

Telephone: +1 877.292.1701

Fax: 949.266.9273

Europe Headquarters

Email: salesemea@addonnetworks.com

Telephone: +44 1285 842070