

OSFP-800GB-2XDR4-LPO-J-AO

Juniper Networks® Compatible TAA 800GBase-2xDR4 PAM4 OSFP-IHS Transceiver (SMF, 1310nm, 500m, 2xMPO-12, DOM, CMIS 5.0) LPO

Features

- OSFP MSA Compliant
- Supports 106.25Gbps Data Rate Per Channel
- Dual MPO-12 Connector APC
- 1310nm PIN Array for up to 500m Reach over SMF
- Electrically Hot-Pluggable
- Integrated Silicon Photonics Modulator Chip 1310nm High-Power DFB Laser
- Operating Temperature: 0 to 70 Celsius
- Single 3.3V Power Supply
- RoHS Compliant and Lead-Free



Applications

- 800GBase Ethernet

Product Description

This Juniper Networks® compatible OSFP-IHS Transceiver provides 800GBase-2xDR4 throughput up to 500m over single-mode fiber (SMF) PAM4 using a wavelength of 1310nm via a 2xMPO-12 connector. It can operate at temperatures between 0 and 70C. All of our transceivers are built to comply with Multi-Source Agreement (MSA) standards and are uniquely serialized and tested for data-traffic and application to ensure seamless network integration. Additional product features include Digital Optical Monitoring (DOM) support which allows access to real-time operating parameters. This transceiver is Trade Agreements Act (TAA) compliant. We stand behind the quality of our products and proudly offer a limited lifetime warranty.

AddOn's transceivers are RoHS compliant and lead-free.

TAA refers to the Trade Agreements Act (19 U.S.C. & 2501-2581), which is intended to foster fair and open international trade. TAA requires that the U.S. Government may acquire only "U.S.-made or designated country end products."



Absolute Maximum Ratings

Parameter	Symbol	Min.	Typ.	Max.	Unit	Notes
Power Supply Voltage	Vcc	-0.5		3.6	V	
Storage Temperature	Tstg	-40		85	°C	
Operating Case Temperature	Tc	0		70	°C	1
Relative Humidity	RH	5		85	%	
Optical Receiver Damage Threshold Input	Pdmg	5.0			dBm	
Data Rate	DR		53.125 @ PAM4		Gbps	2
Transmission Distance	TD			500	M	
Coupled Fiber		Single-Mode Fiber				3
Power Supply Voltage	Vcc	3.135	3.3	3.465	V	
Power Supply Current	Icc			2424	mA	4

Notes:

1. Without air flow.
2. Each optical channel.
3. 9/125 μ m SMF.
4. When Vcc is 3.3V.

Link Power Budget

Parameter	Symbol	Min.	Typ.	Max.	Unit	Notes
Power Budget for Maximum TDECQ			7.8		dB	
Operating Distance			500		m	
Channel Insertion Loss			4		dB	
Allocation for Penalties for Maximum TDECQ			3.8		dB	

Optical Characteristics

Parameter	Symbol	Min.	Typ.	Max.	Unit	Notes
Transmitter						
Signaling Speed Per Lane			53.125 ± 100ppm		GBd	
Modulation Format			PAM4			
Lane Wavelengths	λ	1304.5		1317.5	nm	1
Average Launch Power Per Lane		-2.9		4.0	dBm	
Transmit OMA Per Lane		-0.8		4.2	dBm	
Transmitter and Dispersion Eye Closure for PAM4 (TDECQ) Per Lane	TDECQ			3.4	dB	
SMSR		30			dB	
Optical Extinction Ratio	ER	3.5			dB	
Average Launch Power Off Per Lane	Poff			-15	dBm	
RIN _{17.1} OMA (Maximum)	RIN			-136	dB/Hz	
Transmitter Reflectance	TR			-26	dB	
Receiver						
Signaling Speed Per Lane			53.125 ± 100ppm		GBD	
Modulation Format			PAM4			
Lane Wavelengths	λ	1304.5		1317.5	nm	1
Damage Threshold Per Lane		5.0			dBm	2
Receive Power (OMA) Per Lane	ROMA			4.2	dBm	
Average Input Power Per Channel	RXpx	-5.9		4.0	dBm	
Receiver Sensitivity (OMA) Per Lane	RXsens			-4.4	dBm	3
Receiver Reflectance	RR			-26	dB	

Notes:

1. The wavelength assignment is suitable for all channels.
2. Measured with PRBS31Q test pattern and BER@ 2.4×10^{-4} .
3. The receiver shall be able to tolerate, without damage, continuous exposure to an optical input signal having this average power level.

Pin Descriptions

Pin	Symbol	Name/Description	Notes
1	GND	Module Ground.	1
2	Tx2+	Transmitter Non-Inverted Data.	
3	Tx2-	Transmitter Inverted Data.	
4	GND	Module Ground.	1
5	Tx4+	Transmitter Non-Inverted Data.	
6	Tx4-	Transmitter Inverted Data.	
7	GND	Module Ground.	1
8	Tx6+	Transmitter Non-Inverted Data.	
9	Tx6-	Transmitter Inverted Data.	
10	GND	Module Ground.	1
11	Tx8+	Transmitter Non-Inverted Data.	
12	Tx8-	Transmitter Inverted Data.	
13	GND	Module Ground.	1
14	SCL	2-Wire Serial Interface Clock.	2
15	Vcc	+3.3V Power Supply.	
16	Vcc	+3.3V Power Supply.	
17	LPWn/PRSn	Low-Power Mode/Module Present.	
18	GND	Module Ground.	1
19	Rx7-	Receiver Inverted Data.	
20	Rx7+	Receiver Non-Inverted Data.	
21	GND	Module Ground.	1
22	Rx5-	Receiver Inverted Data.	
23	Rx5+	Receiver Non-Inverted Data.	
24	GND	Module Ground.	1
25	Rx3-	Receiver Inverted Data.	
26	Rx3+	Receiver Non-Inverted Data.	
27	GND	Module Ground.	1
28	Rx1-	Receiver Inverted Data.	
29	Rx1+	Receiver Non-Inverted Data.	
30	GND	Module Ground.	1
31	GND	Module Ground.	1
32	Rx2+	Receiver Non-Inverted Data.	
33	Rx2-	Receiver Inverted Data.	
34	GND	Module Ground.	1
35	Rx4+	Receiver Non-Inverted Data.	
36	Rx4-	Receiver Inverted Data.	
37	GND	Module Ground.	1

38	Rx6+	Receiver Non-Inverted Data.	
39	Rx6-	Receiver Inverted Data.	
40	GND	Module Ground.	1
41	Rx8+	Receiver Non-Inverted Data.	
42	Rx8-	Receiver Inverted Data.	
43	GND	Module Ground.	1
44	INT/RSTn	Module Input/Module Reset.	
45	Vcc	+3.3V Power Supply.	
46	Vcc	+3.3V Power Supply.	
47	SDA	2-Wire Serial Interface Data.	2
48	GND	Module Ground.	1
49	Tx7-	Transmitter Inverted Data.	
50	Tx7+	Transmitter Non-Inverted Data.	
51	GND	Module Ground.	1
52	Tx5-	Transmitter Inverted Data.	
53	Tx5+	Transmitter Non-Inverted Data.	
54	GND	Module Ground.	1
55	Tx3-	Transmitter Inverted Data.	
56	Tx3+	Transmitter Non-Inverted Data.	
57	GND	Module Ground.	1
58	Tx1-	Transmitter Inverted Data.	
59	Tx1+	Transmitter Non-Inverted Data.	
60	GND	Module Ground.	1

Notes:

1. OSFP uses common ground (GND) for all signals and supply (power). All are common within the OSFP module, and all module voltages are referenced to this potential unless otherwise noted. Connect these directly to the host board signal common ground plane.
2. Open-drain with pull-up resistor on the host.

Electrical Pad Layout

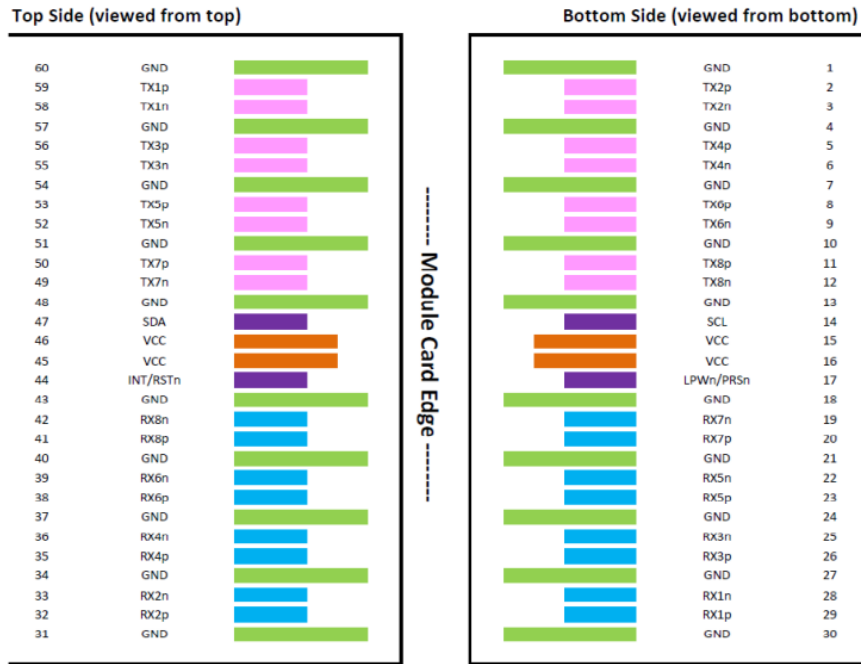

Transceiver Block Diagram

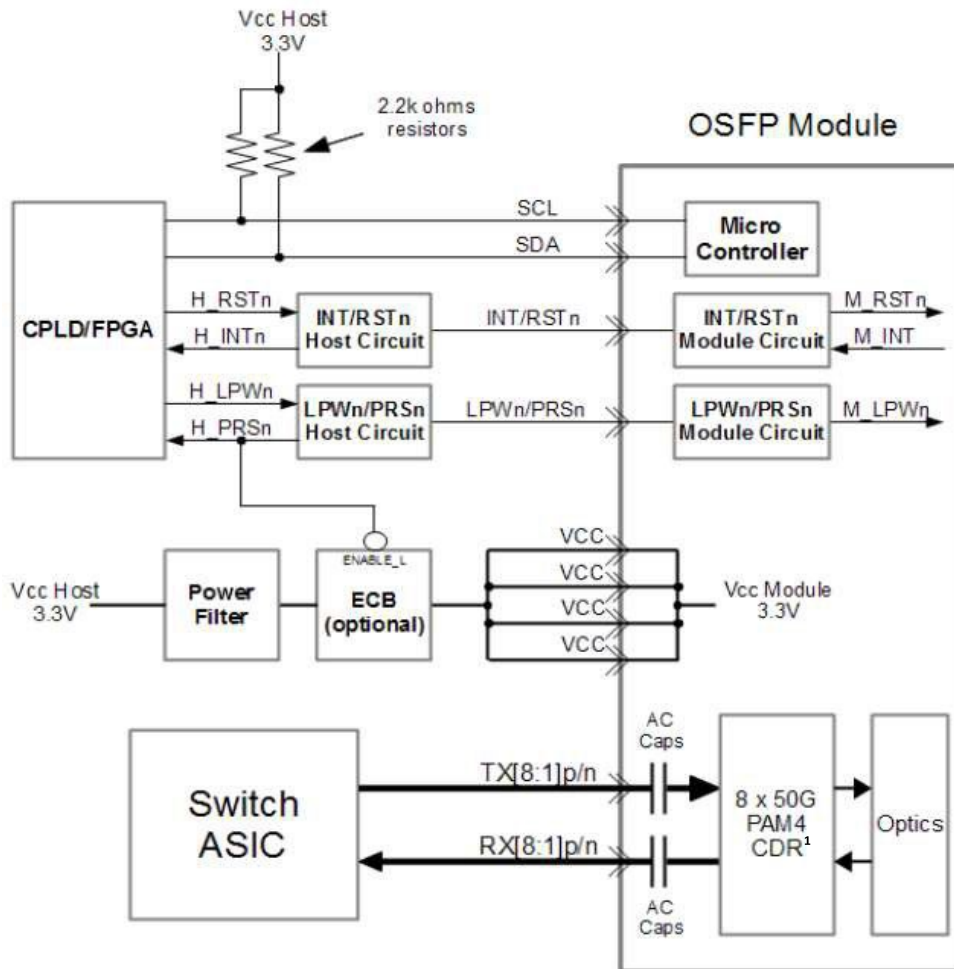

Mechanical Specifications

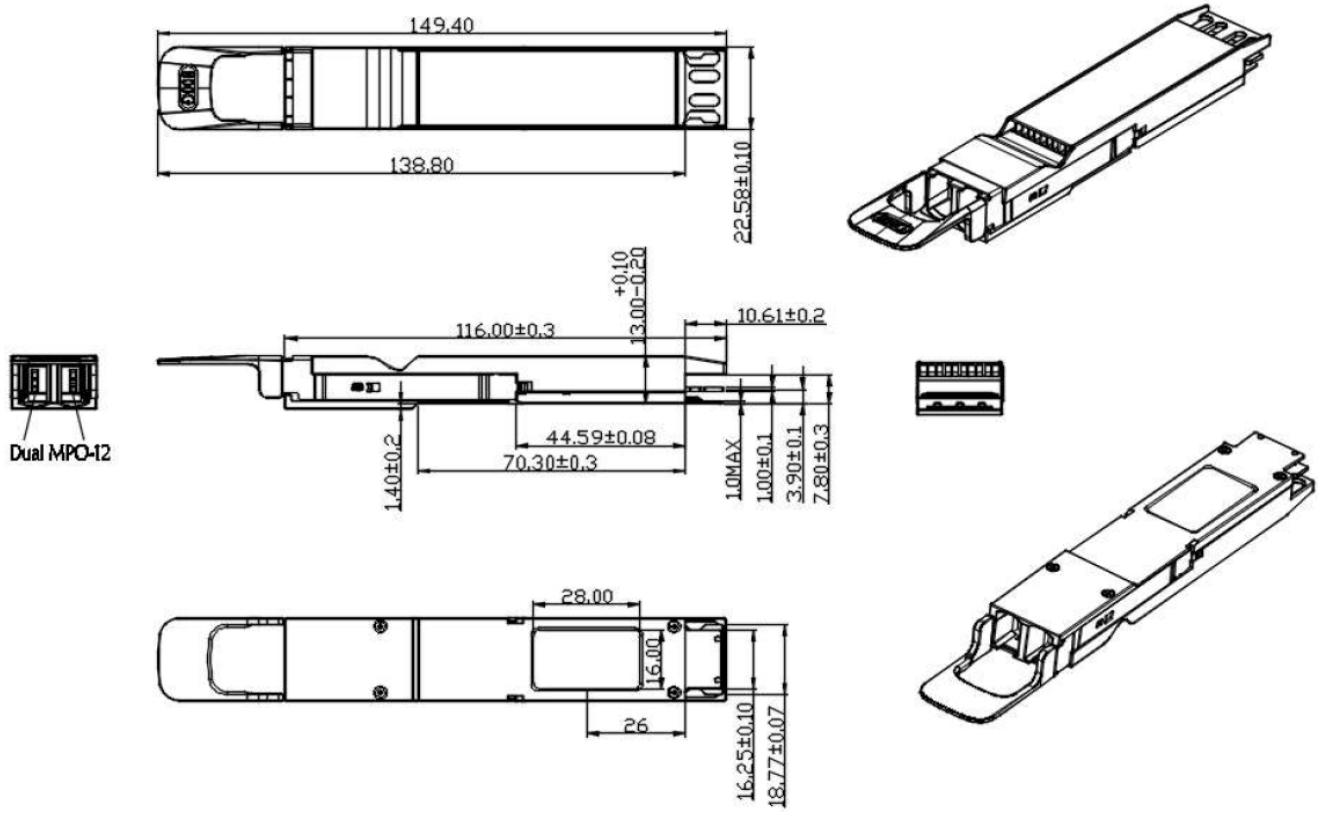

About AddOn Networks

In 1999, AddOn Networks entered the market with a single product. Our founders fulfilled a severe shortage for compatible, cost-effective optical transceivers that compete at the same performance levels as leading OEM manufacturers. Adhering to the idea of redefining service and product quality not previously had in the fiber optic networking industry, AddOn invested resources in solution design, production, fulfillment, and global support.

Combining one of the most extensive and stringent testing processes in the industry, an exceptional free tech support center, and a consistent roll-out of innovative technologies, AddOn has continually set industry standards of quality and reliability throughout its history.

Reliability is the cornerstone of any optical fiber network and is ingrained in AddOn's DNA. It has played a key role in nurturing the long-term relationships developed over the years with customers. AddOn remains committed to exceeding industry standards with certifications ranging from NEBS Level 3 to ISO 9001:2015 with every new development while maintaining the signature reliability of its products.



U.S. Headquarters

Email: sales@addonnetworks.com

Telephone: +1 877.292.1701

Fax: 949.266.9273

Europe Headquarters

Email: salesemea@addonnetworks.com

Telephone: +44 1285 842070