

JNP-QSFP-100G-ER4-OTU4-AO

Juniper Networks® JNP-QSFP-100G-ER4-OTU4 Compatible TAA OTU-4-ER4 100GbE Dual-Rate QSFP28 Transceiver (SMF, 1295nm to 1309nm, 40km, LC, DOM)

Features

- SFF-8665 Compliance
- Duplex LC Connector
- Commercial Temperature 0 to 70 Celsius
- Single-mode Fiber
- Hot Pluggable
- Excellent ESD Protection
- Metal with Lower EMI
- RoHS Compliant and Lead Free



Applications

- OTN OTU4
- 100GBase Ethernet
- Access and Enterprise

Product Description

This Juniper Networks® JNP-QSFP-100G-ER4-OTU4 compatible QSFP28 transceiver provides OTU-4-ER4 100GbE Dual-Rate ER4 throughput up to 40km over single-mode fiber (SMF) using a wavelength of 1295nm to 1309nm via an LC connector. It is guaranteed to be 100% compatible with the equivalent Juniper Networks® transceiver. This easy to install, hot swappable transceiver has been programmed, uniquely serialized and data-traffic and application tested to ensure that it will initialize and perform identically. Digital optical monitoring (DOM) support is also present to allow access to real-time operating parameters. This transceiver is Trade Agreements Act (TAA) compliant. We stand behind the quality of our products and proudly offer a limited lifetime warranty.

AddOn's transceivers are RoHS compliant and lead-free.

TAA refers to the Trade Agreements Act (19 U.S.C. & 2501-2581), which is intended to foster fair and open international trade. TAA requires that the U.S. Government may acquire only "U.S.-made or designated country end products."



Regulatory Compliance

- ESD to the Electrical PINs: compatible with MIL-STD-883E Method 3015.4
- ESD to the LC Receptacle: compatible with IEC 61000-4-3
- EMI/EMC compatible with FCC Part 15 Subpart B Rules, EN55022:2010
- Laser Eye Safety compatible with FDA 21CFR, EN60950-1& EN (IEC) 60825-1,2
- RoHS compliant with EU RoHS 2.0 directive 2015/863/EU

Absolute Maximum Ratings

Parameter	Symbol	Min.	Typ.	Max.	Unit
Maximum Supply Voltage	V _{cc}	0		3.6	V
Storage Temperature	T _s	-40		85	°C
Operating Case Temperature	T _{op}	0		70	°C
Relative Humidity	RH	5		85	%
Damage Threshold, each lane	THd	5.5			dBm
Link Distance with G.652				40	km

Electrical Characteristics

Parameter	Symbol	Min	Typ	Max	Unit	Notes
Supply Voltage	Vcc	3.135	3.3	3.465	V	
Power dissipation				5	W	
Supply Current	Icc			1.4430	A	Steady state
Transmitter						
Data Rate, each lane			25.78125		Gbps	1
			27.9525		Gbps	2
Differential Voltage pk-pk	Vpp			900	mV	At 1 MHz
Common Mode Voltage	Vcm	-350		2850	mV	
Transition time	Trise/Tfall	10			ps	20%~80%
Differential Termination Resistance Mismatch				10	%	
Eye width	EW15	0.46			UI	
Eye height	EH15	95			mV	
Receiver						
Data Rate, each lane			25.78125		Gbps	1
			27.9525		Gbps	2
Differential Termination Resistance Mismatch				10	%	At 1 MHz
Differential output voltage swing	Vout, pp			900	mV	
Common Mode Noise, RMS	Vrms			17.5	mV	
Transition time	Trise/Tfall	12			ps	20%~80%
Eye width	EW15	0.57			UI	
Eye height	EH15	228			mV	

Notes:

1. For use of 100GBASE-ER4.
2. For use of OTU4.

Optical Characteristics

100GBASE-ER4 Operation (EOL, TOP = 0 to +70 °C , VCC = 3.135 to 3.465 Volts)

Parameter	Symbol	Min	Typical	Max	Unit	Notes
Transmitter						
Signaling Speed per Lane		25.78125 ± 100 ppm			Gb/s	
Transmit wavelengths	L1	1294.53		1296.59	nm	
	L2	1299.02		1301.09	nm	
	L3	1303.54		1305.63	nm	
	L4	1308.09		1310.19	nm	
Total Average Launch Power	Po			8.9	dBm	
Average launch power, each lane	Po	-2.9		2.9	dBm	
Optical Modulation Amplitude (OMA), each lane	OMA	0.1		4.5	dBm	
Difference in launch power between any two lanes(Average and OMA)				3.6	dB	
Transmitter and Dispersion Penalty (TDP), each lane	TDP			2.5	dB	
Extinction Ratio	ER	8			dB	
RIN _{20OMA}				-130	dB/Hz	
Side Mode Suppression Ratio	SMSR	30			dB	
Optical Return Loss Tolerance	ORLT			20	dB	
Transmitter reflectance				-12	dB	
Transmitter eye mask definition {X1, X2, X3, Y1, Y2, Y3}		{0.25, 0.4, 0.45, 0.25, 0.28, 0.4}				1
Mask margin		5			%	1
Receiver						
Signaling Speed per Lane		25.78125 ±100 ppm			Gb/s	
Receive wavelengths	L1	1294.53		1296.59	nm	
	L2	1299.02		1301.09	nm	
	L3	1303.54		1305.63	nm	
	L4	1308.09		1310.19	nm	
Damage threshold, each lane	P _{damage}	5.5			dBm	
Average receiver power, each lane		-20.9		-3.5	dBm	
Receiver power, each lane(OMA)				-3.5	dBm	
Receiver Reflectance	R _f			-26	dB	
Receiver sensitivity (AOP), each lane	S			-20.9	dBm	2
Receiver 3 dB electrical upper cutoff frequency, each lane				31	GHz	
LOS Assert	LOSA	-33			dBm	

LOS Deassert	LOSD			-22	dBm	
LOS Hysteresis	LOSH	0.5			dB	

Notes:

1. Hit ratio 5×10^{-5} .
2. Sensitivity is specified at BER@1E-12 without FEC.

Optical Characteristics

OTU4 Operation (EOL, TOP = 0 to +70 °C , VCC = 3.135 to 3.465 Volts)

Parameter	Symbol	Min	Typical	Max	Unit	Notes
Transmitter						
Signaling Speed per Lane		27.9525 ± 20 ppm			Gb/s	
Transmit wavelengths	L1	1294.53		1296.59	nm	
	L2	1299.02		1301.09	nm	
	L3	1303.54		1305.63	nm	
	L4	1308.09		1310.19	nm	
Total Average Launch Power	Po			8.9	dBm	
Average launch power, each lane	Po	-2.7		2.9	dBm	
Difference in launch power between any two lanes (Average and OMA)				3.6	dB	
Extinction Ratio	ER	8			dB	
Optical Return Loss Tolerance	ORLT			20	dB	
Transmitter reflectance				-26	dB	
Transmitter eye mask definition {X1, X2, X3, Y1, Y2, Y3}		{0.25, 0.4, 0.45, 0.25, 0.28, 0.4}				1
Mask margin		5			%	1
Receiver						
Signaling Speed per Lane		27.9525 ± 20 ppm			Gb/s	
Receive wavelengths	L1	1294.53		1296.59	nm	
	L2	1299.02		1301.09	nm	
	L3	1303.54		1305.63	nm	
	L4	1308.09		1310.19	nm	
Average receiver power, each lane		-20.7		-3.5	dBm	
Receiver power, each lane(OMA)				-3.5	dBm	
Difference in receive power between any two lanes (Average and OMA)				4.5		
Receiver Reflectance	Rf			-26	dB	
Receiver sensitivity (AOP), each lane	S			-23.2	dBm	2

Receiver 3 dB electrical upper cutoff frequency, each lane				31	GHz	
LOS Assert	LOSA	-33			dBm	
LOS Deassert	LOSD			-24	dBm	
LOS Hysteresis	LOSH	0.5			dB	

Notes:

1. Hit ratio 5×10^{-5} .
2. Sensitivity is specified at BER@5E-5 with FEC.

Electrical Pin-out Details

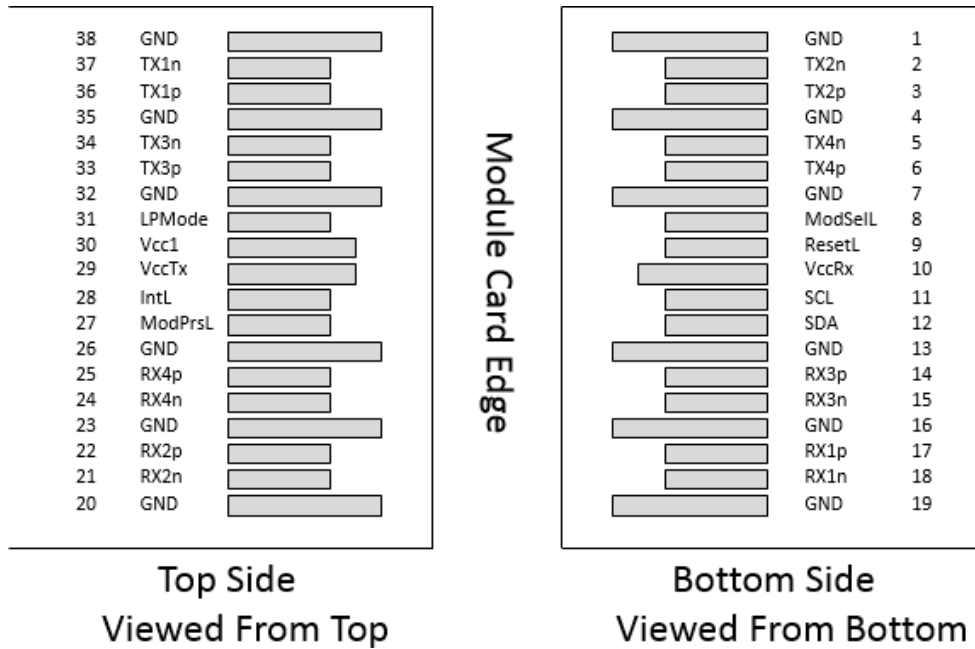

Pin Descriptions

Pin	Symbol	Name/Descriptions	Ref.
1	GND	Ground	1
2	Tx2n	Transmitter Inverted Data Input	
3	Tx2p	Transmitter Non-Inverted Data Input	
4	GND	Ground	1
5	Tx4n	Transmitter Inverted Data Input	
6	Tx4p	Transmitter Non-Inverted Data Input	
7	GND	Ground	1
8	ModSelL	Module Select	
9	ResetL	Module Reset	
10	Vcc Rx	+3.3V Power Supply Receiver	
11	SCL	2-wire serial interface clock	
12	SDA	2-wire serial interface data	
13	GND	Ground	1
14	Rx3p	Receiver Non-Inverted Data Output	
15	Rx3n	Receiver Inverted Data Output	
16	GND	Ground	1
17	Rx1p	Receiver Non-Inverted Data Output	
18	Rx1n	Receiver Inverted Data Output	
19	GND	Ground	1
20	GND	Ground	1
21	Rx2n	Receiver Inverted Data Output	
22	Rx2p	Receiver Non-Inverted Data Output	
23	GND	Ground	1
24	Rx4n	Receiver Non-Inverted Data Output	
25	Rx4p	Receiver Inverted Data Output	
26	GND	Ground	1
27	ModPrsL	Module Present	
28	IntL	Interrupt	
29	Vcc Tx	+3.3V Power supply transmitter	
30	Vcc1	+3.3V Power supply	
31	LPMode	Low Power Mode	
32	GND	Ground	1
33	Tx3p	Transmitter Non-Inverted Data Input	
34	Tx3n	Transmitter Inverted Data Input	
35	GND	Ground	1
36	Tx1p	Transmitter Non-Inverted Data Input	
37	Tx1n	Transmitter Inverted Data Input	
38	GND	Ground	1

Notes:

1. Circuit ground is internally isolated from chassis ground.

Recommended Host Board Power Supply Filter Network

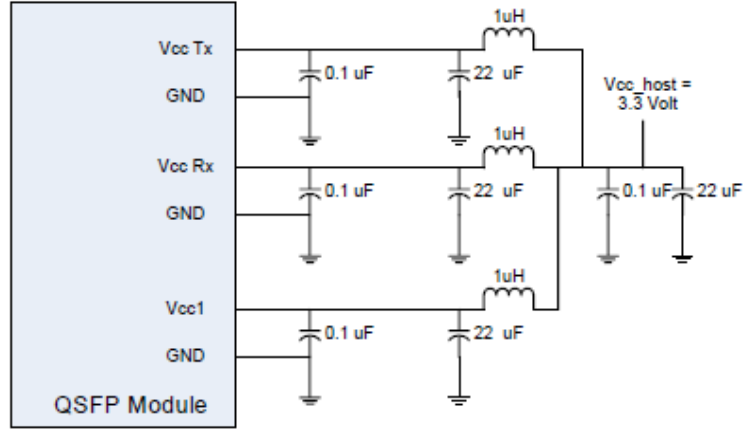

Transceiver Block Diagram

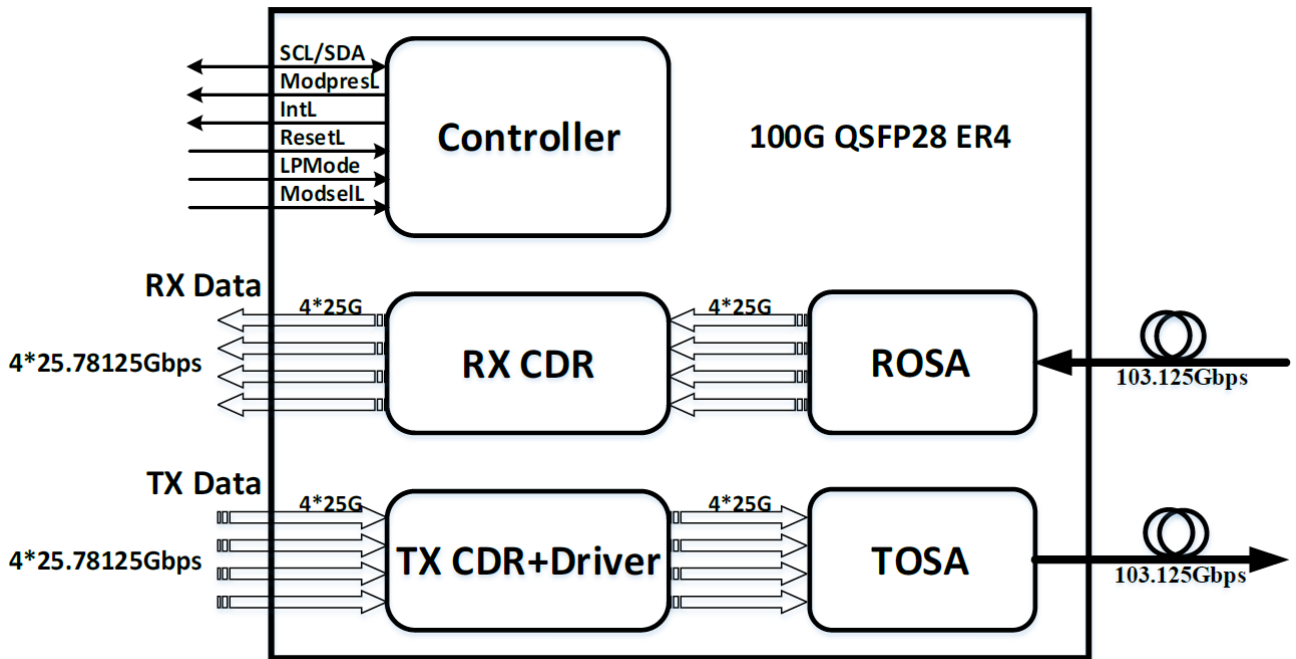

Mechanical Specifications

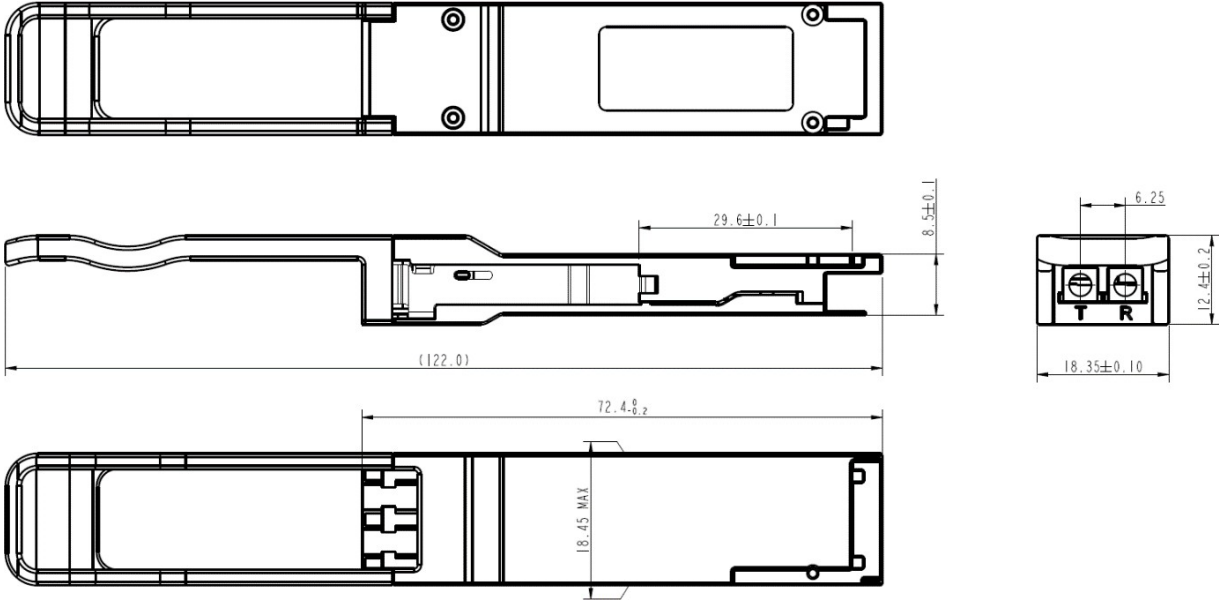

About AddOn Networks

In 1999, AddOn Networks entered the market with a single product. Our founders fulfilled a severe shortage for compatible, cost-effective optical transceivers that compete at the same performance levels as leading OEM manufacturers. Adhering to the idea of redefining service and product quality not previously had in the fiber optic networking industry, AddOn invested resources in solution design, production, fulfillment, and global support.

Combining one of the most extensive and stringent testing processes in the industry, an exceptional free tech support center, and a consistent roll-out of innovative technologies, AddOn has continually set industry standards of quality and reliability throughout its history.

Reliability is the cornerstone of any optical fiber network and is ingrained in AddOn's DNA. It has played a key role in nurturing the long-term relationships developed over the years with customers. AddOn remains committed to exceeding industry standards with certifications ranging from NEBS Level 3 to ISO 9001:2015 with every new development while maintaining the signature reliability of its products.



U.S. Headquarters

Email: sales@addonnetworks.com

Telephone: +1 877.292.1701

Fax: 949.266.9273

Europe Headquarters

Email: salesemea@addonnetworks.com

Telephone: +44 1285 842070